

RIDUTTORI EPICICLOIDALI

PLANETARY GEARBOXES
PLANETENGETRIEBE



REP



EP



TEP



MADE IN ITALY



MADE IN ITALY

Per TRAMEC l'espressione "MADE IN ITALY" possiede un significato molto più profondo di quanto gli venga attribuito nell'uso comune. Tutti i prodotti di TRAMEC sono infatti il risultato di :

PROGETTAZIONE E CREATIVITA' ITALIANA

Ogni riduttore della gamma TRAMEC è completamente progettato in ITALIA, nella sede principale di CALDERARA DI RENO (BOLOGNA), nel cuore della cosiddetta "MOTOR VALLEY" e "PACKAGING VALLEY", un territorio dove la meccanica è da sempre protagonista. Qui gli ingegneri TRAMEC esprimono al meglio la creatività ITALIANA, avvalendosi di strumenti sempre più evoluti per progettare riduttori innovativi e personalizzabili in base a specifiche esigenze del cliente.

PRODUZIONE E MONTAGGIO

Tutti i componenti principali dei riduttori TRAMEC vengono realizzati dalla rete produttiva della nostra Azienda, che si avvale anche dell'esperienza e delle capacità di artigiani selezionati presenti sul medesimo territorio.

Dall'assemblaggio di tali componenti, eseguito con perizia dai nostri tecnici esperti, nascono i riduttori TRAMEC. Il risultato è un prodotto di altissima qualità, come quelli descritti nel catalogo che state sfogliando.

SERVIZIO AL CLIENTE

L'importanza che TRAMEC attribuisce ai propri clienti non si riflette solamente nel fornire un prodotto di elevata qualità, ma anche nel garantire un'assistenza PRE e POST-VENDITA all'altezza del prodotto fornito.

In questo modo, curando al massimo la qualità dei prodotti e rimanendo costantemente al fianco del Cliente, si esprime a pieno l'ITALIANITA' della nostra Azienda.

Ecco cosa significa per TRAMEC l'espressione "MADE IN ITALY".

At TRAMEC "MADE IN ITALY" is an expression with a much deeper meaning , as all TRAMEC products are the result of :

ITALIAN DESIGN & CREATIVITY

TRAMEC is headquartered in CALDERARA DI RENO, BOLOGNA, in the heart of Italy's famous " MOTOR VALLEY" or " PACKAGING VALLEY" where the art of performance is mastered with the science of precision.

Italian design & engineering creativity is allowed via the most advanced tools by TRAMEC engineers in the design of our standard and customized products.

PRODUCTION & ASSEMBLY

The designs of TRAMEC are brought to life through the careful hands of machinists and technicians expressing the local tradition of excellence. All major components are produced , assembled , and inspected within the TRAMEC manufacturing organization.

From this long tradition, expressing performance and precision into objects of exceptional quality , we introduce the TRAMEC'S GEARBOXES.

CUSTOMER CARE

From conception to delivery, we at TRAMEC are focused upon our customers. Our passion is to bring to you the highest performing precision power transmission products, with a never ending commitment to quality and value. From the selection of a new power transmission element, through delivery of the component, to support after the sale, we are aiming to excellence. What we want to convey always is that everything we do is Made in Italy so to assure a complete experience of Italian culture and values.

From everyone at TRAMEC, this is what it means to say "MADE IN ITALY".

Der Begriff "MADE IN ITALY" hat für TRAMEC eine besondere Bedeutung. Alle Produkte von TRAMEC sind das Ergebnis von:

ITALIENISCHER KREATIVITÄT UND PLANUNG

Alle Produkte werden komplett in ITALIEN entworfen. TRAMEC hat ihren Hauptsitz in CALDERARA DI RENO, BOLOGNA, im Herzen Italiens, mitten im MOTOR VALLEY oder PACKAGING VALLEY. Diese Region ist bekannt für ihre fortschrittlichen mechanischen Produkte.

Italienisches Design und Kreativität werden, unter Anwendung moderner Hilfsmittel, durch unsere Ingenieure umgesetzt und in die Planunneuer Produkte mit einbezogen. Das Ergebnis sind qualitativ hochstehende Produkte, die Sie in diesem Katalog finden.

PRODUKTION UND MONTAGE

Alle wichtigen Komponenten der Produkte von TRAMEC sind das Ergebnis des Produktionsnetzes unseres Unternehmens, das sich auf die Erfahrung und die Fähigkeiten der Handwerker in unserem Gebiet stützt. Durch den Zusammenbau dieser Komponenten, der vollkommen von den erfahrenen und ausgezeichneten Technikern von TRAMEC ausgeführt wird.

Aus dieser langen Tradition, die Leistung und Präzision in Objekte von außergewöhnlicher Qualität zum Ausdruck bringt, führen wir die TRAMEC-GETRIEBE ein.

KUNDENDIENST

Von der Planung bis zur Auslieferung steht bei TRAMEC der Kunde im Mittelpunkt. Wir liefern nicht nur qualitativ hochstehende Produkte, sondern beraten unsere Kunden vor und nach dem Kauf durch unseren KUNDENDIENST. Stetigkeit und Kundennähe sehen wir als höchste Priorität.

All das zusammen bedeutet für TRAMEC "MADE IN ITALY".



INDICE

Dati tecnici REP
Dati tecnici EP
Dati tecnici TEP
Simbologia
Selezione

INDEX

REP Technical data
EP Technical data
TEP Technical data
Measurement units
Selection

INHALTSVERZEICHNIS

Technische Daten REP 2
Technische Daten EP 3
Technische Daten TEP 4
Maßeinheiten 5
Getriebeauswahl 6

1.0

**RIDUTTORI EPICICLOIDALI
SERIE REP**

**PLANETARY GEARBOXES
REP SERIES**

**PLANETENGETRIEBE
SERIE REP**

9



2.0

**RIDUTTORI EPICICLOIDALI
SERIE EP**

**PLANETARY GEARBOXES
EP SERIES**

**PLANETENGETRIEBE
SERIE EP**

29



3.0

**RIDUTTORI EPICICLOIDALI
ANGOLARI SERIE TEP**

**RIGHT ANGLE PLANETARY
GEARBOXES TEP SERIES**

**WINKEL-PLANETENGETRIEBE
SERIE TEP**

49



4.0

APPENDICE

APPENDIX

ANHANG

69

5.0

**CONDIZIONI GENERALI
DI VENDITA**

**TERM AND CONDITIONS
OF SALE**

**ALLGEMEINE
VERKAUFSBEDINGUNGEN**

73

REP 075																						Stadi Steps Stufenzahl			
Stadi Steps Stufenzahl	1				2								3									1	2	3	
i	3	4	5	6	9	12	16	20	24	30	36	27	36	48	64	80	100	120	144	180	216				
T _{2N}	35	45	35	30	40	50	50	50	50	40	35	40	55	55	55	55	55	55	55	40	35	n _{1nom}	4000	4500	5000
T _{2A}	55	65	55	50	60	70	70	70	70	60	55	60	80	80	80	80	80	80	80	60	55	n _{1max}	6000		
T _{2S}	110	130	110	100	120	140	140	140	140	120	110	120	150	150	150	150	150	150	150	120	110	LpA	< 70		
J _{min}	0.16	0.14	0.12	0.11	0.16	0.16	0.14	0.12	0.11	0.11	0.11	0.16	0.16	0.16	0.14	0.12	0.11	0.11	0.11	0.11	0.11	Lh	20000		
J _{max}	0.25	0.22	0.20	0.19	0.25	0.25	0.22	0.20	0.19	0.19	0.19	0.25	0.25	0.25	0.22	0.20	0.20	0.19	0.19	0.19	0.19	F _{R2}	1400		
Rt	4																					F _{A2}	700		
Td	0.96				0.93								0.91									α _{max}	4'	6'	8'

Pag. Seite
18

REP 100																						Stadi Steps Stufenzahl			
Stadi Steps Stufenzahl	1				2								3									1	2	3	
i	3	4	5	6	9	12	16	20	24	30	36	27	36	48	64	80	100	120	144	180	216				
T _{2N}	90	110	90	75	100	115	115	115	115	85	75	100	120	120	120	120	120	120	120	95	80	n _{1nom}	4000	4500	5000
T _{2A}	145	170	130	120	160	180	180	180	180	140	130	160	190	190	190	190	190	190	190	150	130	n _{1max}	6000		
T _{2S}	290	340	260	240	320	360	360	360	360	280	260	320	380	380	380	380	380	380	380	300	260	LpA	< 70		
J _{min}	0.47	0.35	0.28	0.26	0.48	0.47	0.34	0.28	0.26	0.25	0.25	0.48	0.48	0.47	0.34	0.28	0.28	0.25	0.25	0.25	0.25	Lh	20000		
J _{max}	0.80	0.69	0.62	0.60	0.82	0.81	0.68	0.62	0.59	0.59	0.59	0.82	0.82	0.81	0.68	0.62	0.61	0.59	0.59	0.59	0.59	F _{R2}	2100		
Rt	11																					F _{A2}	1050		
Td	0.96				0.93								0.91									α _{max}	4'	6'	8'

Pag. Seite
20

REP 125																						Stadi Steps Stufenzahl			
Stadi Steps Stufenzahl	1				2								3									1	2	3	
i	3	4	5	7	9	12	16	20	28	35	49	36	48	64	80	100	140	196	245	343					
T _{2N}	220	230	200	160	250	260	260	260	260	230	180	280	280	280	280	280	280	280	250	200	n _{1nom}	3000	3500	4000	
T _{2A}	350	370	320	300	400	420	420	420	420	370	350	450	450	450	450	450	450	450	400	370	n _{1max}	5000			
T _{2S}	700	750	650	600	800	850	850	850	850	750	700	900	900	900	900	900	900	900	800	750	LpA	< 70			
J _{min}	1.91	1.18	0.84	0.64	1.93	1.85	1.14	0.82	0.62	0.63	0.62	1.92	1.84	1.14	0.81	0.80	0.62	0.61	0.61	0.61	Lh	20000			
J _{max}	5.10	4.36	4.02	3.82	5.11	5.03	4.33	4.00	3.81	3.81	3.81	5.11	5.03	4.32	4.00	3.98	3.80	3.80	3.79	3.79	F _{R2}	3700			
Rt	32																					F _{A2}	1850		
Td	0.96				0.93								0.91									α _{max}	4'	6'	8'

Pag. Seite
22

REP 150																						Stadi Steps Stufenzahl			
Stadi Steps Stufenzahl	1				2								3									1	2	3	
i	3	4	5	7	9	12	16	20	28	35	49	36	48	64	80	100	140	196	245	343					
T _{2N}	430	470	410	340	500	560	560	560	560	470	370	600	600	600	600	600	600	600	500	450	n _{1nom}	3000	3500	4000	
T _{2A}	700	750	650	600	800	900	900	900	900	750	700	950	950	950	950	950	950	950	800	750	n _{1max}	5000			
T _{2S}	1400	1500	1300	1200	1600	1800	1800	1800	1800	1500	1400	1900	1900	1900	1900	1900	1900	1900	1600	1500	LpA	< 70			
J _{min}	6.58	4.64	3.64	3.05	6.54	6.32	4.49	3.55	3.01	2.99	2.97	6.51	6.31	4.49	3.55	3.61	2.98	2.97	2.97	2.97	Lh	20000			
J _{max}	12.94	11.00	10.01	9.42	12.90	12.69	10.86	9.92	9.37	9.35	9.34	12.87	12.67	10.85	9.91	9.87	9.35	9.34	9.34	9.34	F _{R2}	6600			
Rt	60																					F _{A2}	3300		
Td	0.96				0.93								0.91									α _{max}	4'	6'	8'

Pag. Seite
24

F_{R2} Carico radiale nominale in uscita [N] a 300min⁻¹
F_{A2} Carico assiale in uscita [N] a 300min⁻¹

Rated output radial load [N] at 300min⁻¹
Output axial load [N] at 300min⁻¹

Nenn-Radiallast an der Abtriebswelle bei 300min⁻¹
Axiallast an der Abtriebswelle bei 300min⁻¹

Dati tecnici EP

EP Technical data

Technische Daten EP

EP 55																		Stadi Steps Stufenzahl			
Stadi Steps Stufenzahl	1					2															
i	3	4	5	7	10	9	12	15	16	20	25	28	35	40	50	70	100	1	2		
T _{2N}	12	14	16	12	10	14	16	16	16	16	16	16	16	16	16	14	12	n _{1nom}	4000		
T _{2A}	22	24	24	22	20	24	28	28	28	28	28	28	28	28	28	24	22	n _{1max}	5000		
T _{2S}	44	48	48	44	40	48	56	56	56	56	56	56	56	56	56	48	44	LpA	< 70		
J _{min}	0.07	0.06	0.06	0.06	0.05	0.07	0.07	0.07	0.06	0.06	0.06	0.06	0.06	0.05	0.05	0.05	0.05	Lh	20000		
J _{max}	0.09	0.08	0.08	0.07	0.07	0.09	0.09	0.09	0.08	0.08	0.08	0.07	0.07	0.07	0.07	0.07	0.07	F _{R2}	300		
Rt	1.0					1.0												0.9		F _{A2}	450
Td	0.96					0.93												α _{max}		8'	10'

Pag. Page Seite

36

EP 75																		Stadi Steps Stufenzahl			
Stadi Steps Stufenzahl	1					2															
i	3	4	5	7	10	9	12	15	16	20	25	28	35	40	50	70	100	1	2		
T _{2N}	22	28	32	28	20	26	32	36	36	36	36	36	36	36	36	30	22	n _{1nom}	4000		
T _{2A}	40	45	50	45	40	50	60	60	60	60	60	60	60	60	60	50	45	n _{1max}	5000		
T _{2S}	80	90	100	90	80	100	120	120	120	120	120	120	120	120	120	100	90	LpA	< 70		
J _{min}	0.17	0.12	0.11	0.09	0.09	0.16	0.16	0.15	0.12	0.12	0.10	0.09	0.09	0.09	0.09	0.09	0.09	Lh	20000		
J _{max}	0.22	0.16	0.15	0.14	0.13	0.21	0.20	0.20	0.16	0.16	0.15	0.14	0.14	0.13	0.13	0.13	0.13	F _{R2}	1800		
Rt	3.5					3.5												3		F _{A2}	1400
Td	0.96					0.93												α _{max}		8'	10'

Pag. Page Seite

38

EP 90																		Stadi Steps Stufenzahl			
Stadi Steps Stufenzahl	1					2															
i	3	4	5	7	10	9	12	15	16	20	25	28	35	40	50	70	100	1	2		
T _{2N}	50	55	60	55	50	65	70	75	75	75	75	75	75	75	75	65	55	n _{1nom}	4000		
T _{2A}	80	90	100	90	80	100	110	120	120	120	120	120	120	120	120	100	90	n _{1max}	5000		
T _{2S}	160	180	200	180	160	200	220	240	240	240	240	240	240	240	240	200	180	LpA	< 70		
J _{min}	0.53	0.35	0.29	0.24	0.21	0.53	0.51	0.51	0.34	0.34	0.28	0.23	0.23	0.21	0.21	0.21	0.21	Lh	20000		
J _{max}	0.73	0.55	0.49	0.44	0.41	0.73	0.71	0.70	0.54	0.53	0.48	0.43	0.43	0.41	0.41	0.41	0.41	F _{R2}	2600		
Rt	9.0					9.0												7.5		F _{A2}	2000
Td	0.96					0.93												α _{max}		8'	10'

Pag. Page Seite

40

EP 120																		Stadi Steps Stufenzahl			
Stadi Steps Stufenzahl	1					2															
i	3	4	5	7	10	9	12	15	16	20	25	28	35	40	50	70	100	1	2		
T _{2N}	120	150	180	150	100	150	180	220	220	220	220	220	220	220	220	170	110	n _{1nom}	3000		
T _{2A}	190	240	290	220	180	240	290	350	350	350	350	350	350	350	350	270	200	n _{1max}	4000		
T _{2S}	400	500	600	460	380	500	600	700	700	700	700	700	700	700	700	540	400	LpA	< 70		
J _{min}	2.02	1.13	0.86	0.62	0.50	2.00	1.92	1.88	1.07	1.05	0.80	0.60	0.60	0.50	0.49	0.49	0.49	Lh	20000		
J _{max}	4.17	3.28	3.01	2.77	2.65	4.15	4.07	4.03	3.22	3.20	2.95	2.75	2.75	2.65	2.64	2.64	2.64	F _{R2}	4500		
Rt	32					30												28		F _{A2}	4000
Td	0.96					0.93												α _{max}		8'	10'

Pag. Page Seite

42

EP 155																		Stadi Steps Stufenzahl			
Stadi Steps Stufenzahl	1					2															
i	3	4	5	7	10	9	12	15	16	20	25	28	35	40	50	70	100	1	2		
T _{2N}	240	320	380	300	220	320	400	500	500	500	500	500	500	500	500	350	250	n _{1nom}	3000		
T _{2A}	420	540	600	480	400	480	600	750	750	750	750	750	750	750	750	560	460	n _{1max}	4000		
T _{2S}	880	1140	1260	1000	850	1000	1250	1500	1500	1500	1500	1500	1500	1500	1500	1120	920	LpA	< 70		
J _{min}	6.97	4.45	3.57	2.86	2.49	6.84	6.55	6.46	4.22	4.16	3.38	2.78	2.76	2.45	2.44	2.44	2.43	Lh	20000		
J _{max}	13.59	11.07	10.19	9.48	9.11	13.46	13.18	13.08	10.84	10.78	10.00	9.40	9.38	9.07	9.06	9.06	9.05	F _{R2} (AA) F _{R2} (TT)	6500 5300		
Rt	60					60												50		F _{A2} (AA) F _{A2} (TT)	3250 2650
Td	0.96					0.93												α _{max}		8'	10'

Pag. Page Seite

44

F_{R2} Carico radiale nominale in uscita [N] a 100min⁻¹
F_{A2} Carico assiale in uscita [N] a 100min⁻¹

Rated output radial load [N] at 100min⁻¹
Output axial load [N] at 100min⁻¹

Nenn-Radiallast an der Abtriebswelle bei 100min⁻¹
Axiallast an der Abtriebswelle bei 100min⁻¹

TEP 55																		Stadi Steps Stufenzahl		Pag. Page Seite
Stadi Steps Stufenzahl	2					3										2	3			
i	3	4	5	7	10	9	12	15	16	20	25	28	35	40	50			70	100	n _{1nom}
T _{2N}	9	12	15	12	10	14	16	16	16	16	16	16	16	16	16	14	12	3500	5000	
T _{2A}	13	17	22	22	20	24	28	28	28	28	28	28	28	28	28	24	22	LpA	< 65	
T _{2S}	26	34	44	44	40	48	56	56	56	56	56	56	56	56	56	48	44	LpA	< 65	
J	Vedi pag. 53 / See page 53 / Siehe auf Seite 53																	Lh	20000	56
R _t	0.85					0.8		0.85								0.8		F _{R2}	300	
R _d	0.94					0.91										F _{A2}	450			
Kg	1.3					2.3										α _{max}	17' 20'			
TEP 75																		Stadi Steps Stufenzahl		Pag. Page Seite
Stadi Steps Stufenzahl	2					3										2	3			
i	3	4	5	7	10	9	12	15	16	20	25	28	35	40	50			70	100	n _{1nom}
T _{2N}	18	25	30	28	20	26	32	36	36	36	36	36	36	36	36	30	22	3000	4500	
T _{2A}	30	40	50	45	40	50	60	60	60	60	60	60	60	60	60	50	45	LpA	< 68	
T _{2S}	60	80	100	90	80	100	120	120	120	120	120	120	120	120	120	100	90	LpA	< 68	
J	Vedi pag. 53 / See page 53 / Siehe auf Seite 53																	Lh	20000	58
R _t	2.5					2		2.5								2		F _{R2}	1800	
R _d	0.94					0.91										F _{A2}	1400			
Kg	2.4					3										α _{max}	15' 18'			
TEP 90																		Stadi Steps Stufenzahl		Pag. Page Seite
Stadi Steps Stufenzahl	2					3										2	3			
i	3	4	5	7	10	9	12	15	16	20	25	28	35	40	50			70	100	n _{1nom}
T _{2N}	32	42	54	55	50	65	70	75	75	75	75	75	75	75	75	65	55	3000	4500	
T _{2A}	50	66	84	90	80	100	110	120	120	120	120	120	120	120	120	100	90	LpA	< 68	
T _{2S}	100	132	168	180	160	200	220	240	240	240	240	240	240	240	240	200	180	LpA	< 68	
J	Vedi pag. 54 / See page 54 / Siehe auf Seite 54																	Lh	20000	60
R _t	6.5					6		6.5								6		F _{R2}	2600	
R _d	0.94					0.91										F _{A2}	2000			
Kg	4.6					5.5										α _{max}	15' 18'			
TEP 120																		Stadi Steps Stufenzahl		Pag. Page Seite
Stadi Steps Stufenzahl	2					3										2	3			
i	3	4	5	7	10	9	12	15	16	20	25	28	35	40	50			70	100	n _{1nom}
T _{2N}	60	80	100	140	100	150	180	180	180	180	180	180	180	180	180	170	110	2500	4000	
T _{2A}	108	144	180	220	180	240	290	290	290	290	290	290	290	290	290	270	200	LpA	< 70	
T _{2S}	216	288	360	440	380	500	600	600	600	600	600	600	600	600	600	540	400	LpA	< 70	
J	Vedi pag. 54 / See page 54 / Siehe auf Seite 54																	Lh	20000	62
R _t	16					14.5		16								14.5		F _{R2}	4500	
R _d	0.94					0.91										F _{A2}	4000			
Kg	11.7					12.2										α _{max}	12' 15'			
TEP 155																		Stadi Steps Stufenzahl		Pag. Page Seite
Stadi Steps Stufenzahl	2					3										2	3			
i	3	4	5	7	10	9	12	15	16	20	25	28	35	40	50			70	100	n _{1nom}
T _{2N}	170	230	290	300	220	320	400	430	430	430	430	430	430	430	430	350	250	2500	4000	
T _{2A}	270	360	450	480	400	480	600	650	650	650	650	650	650	650	650	560	460	LpA	< 70	
T _{2S}	540	720	900	1000	850	1000	1250	1300	1300	1300	1300	1300	1300	1300	1300	1120	920	LpA	< 70	
J	Vedi pag. 55 / See page 55 / Siehe auf Seite 55																	Lh	20000	64
R _t	34.5					31		34.5								31		F _{R2 (AA)} F _{R2 (TT)}	6500 5300	
R _d	0.94					0.91										F _{A2 (AA)} F _{A2 (TT)}	3250 2650			
Kg	17.5					22										α _{max}	12' 15'			

F_{R2} Carico radiale nominale in uscita [N] a 100min⁻¹
 F_{A2} Carico assiale in uscita [N] a 100min⁻¹

Rated output radial load [N] at 100min⁻¹
 Output axial load [N] at 100min⁻¹

Nenn-Radiallast an der Abtriebswelle bei 100min⁻¹
 Axiallast an der Abtriebswelle bei 100min⁻¹

Simbologia

Symbols

Verwendete Symbole

Simbologia	Units	Description	English Description	German Description
α_{max}	[arcmin]	Gioco angolare standard	<i>Standard backlash</i>	Standard Winkelspiel
C	—	Coefficiente di dispersione termica	<i>Loss of heat coefficient</i>	Wärmeverlustkoeffizient
F_{A2}	[N]	Carico assiale in uscita [N]	<i>Output axial load [N]</i>	Axiallast an der Abtriebswelle
fc	—	Fattore di ciclo	<i>Cycle factor</i>	Zyklusfaktor
F_{R2}	[N]	Carico radiale nominale in uscita [N]	<i>Rated output radial load [N]</i>	Nenn-Radiallast an der Abtriebswelle [N]
f_v	—	Fattore di ventilazione	<i>Ventilation factor</i>	Lüftungsfaktor
i	—	Rapporto di riduzione nominale	<i>Nominal ratio</i>	Nenn-Untersetzungsverhältnis
J	[kg.cm ²]	Momento d'inerzia riferito all'albero entrata	<i>Moment of inertia referred to input shaft</i>	Trägheitsmoment bzw. Antriebswelle
KU, KM	—	Coefficiente di utilizzo	<i>Duty coefficient</i>	Anwendungskoeffizient
L_h	[h]	Durata cuscinetti	<i>Bearing life</i>	Lebensdauer der Lager
LpA	dB(A)	Livello di rumorosità dB(A) a 3000 min ⁻¹	<i>Noise level dB(A) at 3000 min⁻¹</i>	Geräuschpegel dB(A) bei 3000 min ⁻¹
n_{1 max}	[min ⁻¹]	Velocità massima in entrata	<i>Maximum input speed</i>	Maximale Eingangsrehzahl
n_{1 nom}	[min ⁻¹]	Velocità nominale in entrata	<i>Nominal input speed</i>	Nenn-Eingangsrehzahl
n_{1E}	[min ⁻¹]	Velocità media in ingresso	<i>Average input speed</i>	Durchschnittsrehzahl am Antrieb
n_{2E}	[min ⁻¹]	Velocità di rotazione media in uscita	<i>Average rotation speed at output</i>	Durchschnittsrehzahl am Abtrieb
n_{2N}	[min ⁻¹]	Velocità di rotazione nominale in uscita	<i>Rated rotation speed at output</i>	Nennrehzahl am Abtrieb
P₀	[W]	Potenza persa a vuoto	<i>Loadless friction power</i>	Verlustleistung ohne Last
P₁	[W]	Potenza persa proporzionale alla potenza applicata	<i>Friction power proportional to the applied power</i>	Verlustleistung proportional zu der angewandten Leistung
Rd	—	Rendimento dinamico	<i>Dynamic efficiency</i>	Dynamischer Wirkungsgrad
R_t	[Nm / arcmin]	Rigidità torsionale	<i>Torsional stiffness</i>	Drehfestigkeit
T₀	[°C]	Temperatura ambiente	<i>Ambient temperature</i>	Umgebungstemperatur
T_{max}	[°C]	Temperatura massima ammessa di funzionamento	<i>Max. permitted temperature of operation</i>	Max. zulässige Betriebstemperatur
T_{1AMOT}	[Nm]	Massima coppia di accelerazione del motore	<i>Max. acceleration torque of motor</i>	Maximales Beschleunigungsdrehmoment des Motors
T_{1E}	[Nm]	Coppia media in entrata	<i>Average torque at input</i>	Durchschnittsdrehmoment am Antrieb
T_{1n}	[Nm]	Coppia nominale del motore	<i>Motor rated torque</i>	Nenn Drehmoment des Motors
T_{2A}	[Nm]	Massima coppia di accelerazione in uscita	<i>Max. acceleration torque at output</i>	Maximales Beschleunigungsdrehmoment am Abtrieb
T_{2E}	[Nm]	Coppia media in uscita	<i>Average torque at output</i>	Durchschnittsdrehmoment am Abtrieb
T_{2N}	[Nm]	Coppia nominale intermittente in uscita	<i>Rated intermittent output torque</i>	Nenn-Abtriebsmoment (im Aussetzbetrieb)
T_{2S}	[Nm]	Coppia massima di emergenza in uscita	<i>Maximum emergency output torque</i>	Max. Notmoment am Abtrieb
τC	[s]	Costante di tempo	<i>Time constant</i>	Zeitkonstante
T_s	[°C]	Temperatura massima di equilibrio	<i>Maximum temperature of equilibrium</i>	Max. Gleichgewichtstemperatur
Zh	[1/h]	Numero di cicli ora	<i>Number of cycles per hour</i>	Zyklenzahl pro Stunde

Selezione

Verifica meccanica

La selezione dei riduttori epicicloidali deve essere effettuata valutando se il servizio è intermittente o continuo. Noto il ciclo di lavoro:

Selection

Mechanical check

The selection of the planetary gearboxes depends on whether the duty is continuous or intermittent. The working cycle being:

Getriebeauswahl

Mechanische Prüfung

Bei der Auswahl der Planetengetriebe sollte berücksichtigt werden, ob es um Aussetz- oder Dauerbetrieb handelt. Bei bekannten Arbeitszyklus:

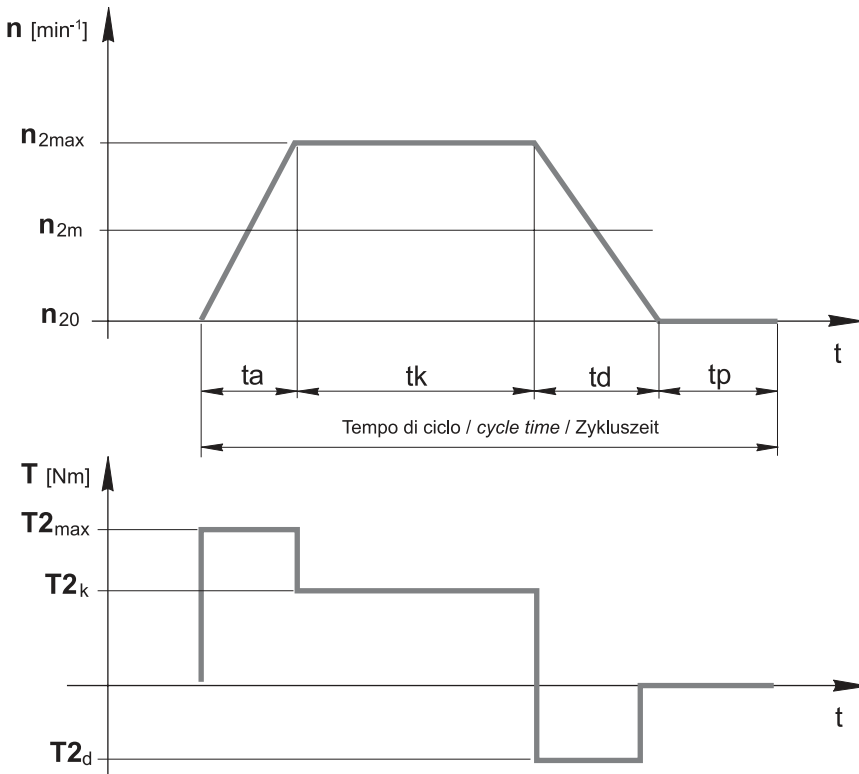

n_{2max} [min ⁻¹]	Velocità massima Max. speed Max. Drehzahl
n_{2m} [min ⁻¹]	Velocità media Average speed Durchschnittsdrehzahl
n_{20} [min ⁻¹]	Velocità zero (motore fermo) Zero speed (motor off) Null Drehzahl (stillstehender Motor)
t_a [s]	Tempo di accelerazione Acceleration time Beschleunigungszeit
t_k [s]	Tempo di funzionamento a regime Standard time of operation Standardbetriebszeit
t_d [s]	Tempo di decelerazione Deceleration time Verzögerungszeit
t_p [s]	Tempo di pausa Pause time Pausenzeit
T_{2max} [Nm]	Coppia massima Max. torque Maximaldrehmoment
T_{2k} [Nm]	Coppia a regime Standard torque Standardbetriebsdrehmoment
T_{2d} [Nm]	Coppia in decelerazione Decelerating torque Verzögerungsdrehmoment

si definiscono i coefficienti di utilizzo KU, KM secondo le seguenti formule:

calculate KU, KM duty coefficients with the following formulae:

darf der Anwendungskoeffizient KU, KM wie folgt kalkuliert werden:

$$KU = \frac{t_a + t_k + t_d}{t_a + t_k + t_d + t_p} \cdot 100 \quad [\%]$$



se:
if:
ob: $KU < 60\%$
 $e / and / und$
 $KM < 20 \text{ min}$



S5 **Funzionamento intermittente**
Intermittent duty
Aussetzbetrieb

e
and
und

$$KM = \frac{t_a + t_k + t_d}{60} \quad [\text{min}]$$



se:
if:
ob: $KU \geq 60\%$
 $o / or / oder$
 $KM \geq 20 \text{ min}$



S1 **Funzionamento continuo**
Continuous duty
Dauerbetrieb

Funzionamento intermittente

Intermittent duty

Aussetzbetrieb

In questo caso, deve essere verificata la seguente relazione:

In case of intermittent duty, the following equation should be checked:

Bei Aussetzbetrieb soll die folgende Relation festgestellt werden

$$1) \quad T_{2A} \geq T_{1AMOT} \cdot i \cdot f_c \cdot Rd$$

$$2) \quad T_{2N} \geq T_{2K}$$

Dove :

T_{2A} = massima coppia di accelerazione in uscita garantita dal riduttore [Nm] (vedi tabelle delle prestazioni)

T_{2N} = coppia nominale intermittente in uscita ammessa dal riduttore [Nm] (vedi tabelle delle prestazioni)

T_{1AMOT} = massima coppia di accelerazione del motore [Nm]

i = rapporto di riduzione

f_c = fattore di ciclo (vedi tabella 1)

Rd = rendimento dinamico (vedi tabella delle prestazioni)

T_{2K} = Coppia a regime

Where:

T_{2A} = max. acceleration torque at output guaranteed by the gearbox [Nm] (see tables of performance)

T_{2N} = rated intermittent allowable torque at output [Nm] (see tables of performance)

T_{1AMOT} = max. acceleration torque of motor [Nm]

i = reduction ratio

f_c = cycle factor (see table 1)

Rd = dynamic efficiency (see table of performance)

T_{2K} = Standard torque

Wobei:

T_{2A} = maximales Beschleunigungsdrehmoment am Abtrieb, das von Getriebe garantiert wird [Nm] (siehe Leistungstabellen)

T_{2N} = Zulässiges intermittierendes Nenn Drehmoment am Abtrieb [Nm] (siehe Leistungstabelle)

T_{1AMOT} = maximales Beschleunigungsdrehmoment des Motors [Nm]

i = Übersetzungsverhältnis

f_c = Zyklusfaktor (siehe Tabelle 1)

Rd = dynamischer Wirkungsgrad (siehe Leistungstabelle)

T_{2K} = Standardbetriebsdrehmoment

Infine, si confronti il valore della velocità in entrata massima consentita (n_{1max} , V. tabella delle prestazioni) con la massima velocità di rotazione raggiunta in entrata dall'applicazione (n'_{1max}). Deve essere:

Finally, the max. allowed input speed (n_{1max} , see table of performance) has to be compared with the max. rotation speed reached by the application at input (n'_{1max}). The result has to be as follows:

Schließlich sollen das zulässige Maximaldrehzahl am Antrieb (n_{1max} , siehe Leistungstabelle) und das in der Applikation erreichten Maximaldrehzahl am Antrieb verglichen werden (n'_{1max}). Das Ergebnis soll wie folgt sein:

$$3) \quad n_{1max} \geq n'_{1max}$$

Funzionamento continuo

Continuous duty

Continuous duty

In questo caso devono essere verificate le seguenti relazioni:

In case of continuous duty the following equations have to be checked:

Bei Dauerbetrieb sind die folgenden Relationen zu prüfen:

$$1) \quad T_{2N} \geq T_{1AMOT} \cdot i \cdot f_c \cdot f_u \cdot Rd$$

$$2) \quad n_{2N} \geq n_{2E}$$

$$3) \quad n_{1max} \geq n'_{1max}$$

Dove :

T_{2A} = massima coppia di accelerazione in uscita garantita dal riduttore [Nm] (vedi tabelle delle prestazioni)

T_{1AMOT} = massima coppia di accelerazione del motore [Nm]

i = rapporto di riduzione

f_c = fattore di ciclo (vedi tabella 1)

Rd = rendimento dinamico (vedi tabella delle prestazioni)

T_{2N} = coppia nominale intermittente in uscita ammessa dal riduttore [Nm] (vedi tabelle delle prestazioni)

n_{2n} = velocità di rotazione nominale in uscita [min^{-1}] (vedi tabelle delle prestazioni: $n_{2N} = n_{1nom}/i$)

n_{2E} = velocità di rotazione media in uscita [min^{-1}] e vale:

Where:

T_{2A} = max. acceleration torque at output guaranteed by the gearbox [Nm] (see tables of performance)

T_{1AMOT} = max. acceleration torque of motor [Nm]

i = reduction ratio

f_c = cycle factor (see table 1)

Rd = dynamic efficiency (see table of performance)

T_{2N} = rated intermittent allowable torque at output [Nm] (see tables of performance)

n_{2n} = rated rotation speed at output [min^{-1}] (see tables of performance $n_{2n} = n_{1nom}/i$)

n_{2E} = average rotation speed at output [min^{-1}]

Wobei:

T_{2A} = maximales Beschleunigungsdrehmoment am Abtrieb, das von Getriebe garantiert wird [Nm] (siehe Leistungstabellen)

T_{1AMOT} = maximales Beschleunigungsdrehmoment des Motors [Nm]

i = Übersetzungsverhältnis

f_c = Zyklusfaktor (siehe Tabelle 1)

Rd = dynamischer Wirkungsgrad (siehe Leistungstabelle)

T_{2N} = Zulässiges intermittierendes Nenn Drehmoment am Abtrieb [Nm] (siehe Leistungstabelle)

n_{2n} = Nenn Drehzahl am Abtrieb [min^{-1}] (siehe Leistungstabelle $n_{2n} = n_{1nom}/i$)

n_{2E} = Durchschnittsdrehzahl am Abtrieb, wird wie folgt kalkuliert:

$$n_{2E} = \frac{n_{2m} \cdot t_a + \dots + n_{2n} \cdot t_n}{t_a + \dots + t_n} \quad [\text{min}^{-1}]$$

Determinazione di f_c

Il valore del fattore di ciclo f_c dipende dal numero di cicli ora Z_h , dove:

Calculation of f_c

The value of f_c cycle factor depends on the number of cycles per hour Z_h :

Berechnung von f_c

Der Wert von f_c Zyklusfaktor hängt von der Zyklenzahl pro Stunde Z_h ab:

$$Z_h = \frac{3600}{t_a + t_k + t_d + t_p} \quad [1/h]$$

Una volta determinato Z_h , consultando la seguente tabella, si ricava f_c da introdurre nelle formule precedenti:

Once Z_h is thus calculated, use the following table to select f_c :

Nachdem Z_h kalkuliert worden ist, dann kann f_c aus der folgenden Tabelle ausgelesen werden:

Tab. 1	Z _h		
	1000	1000 - 2000	2000 - 3000
f_c	1	1.2 - 1.5	1.5 - 2

Determinazione di f_u

Il valore del fattore di utilizzo f_u dipende dal rapporto tra il tempo di funzionamento ed il tempo ciclo:

Calculation of f_u

The value of the utilization factor f_u depends on the ratio between the running time and the cycle time:

Berechnung von f_u

Der Wert von f_u Anwendungsfaktor hängt von dem Verhältnis zwischen der Betriebszeit und der Zykluszeit:

	KU < 60%	60% ≤ KU < 80%	KU ≥ 80%
	f_u	1	1.25

1.0	RIDUTTORI EPICICLOIDALI SERIE REP	PLANETARY GEARBOXES REP SERIES	PLANETENGETRIEBE SERIE REP	
1.1	Caratteristiche	<i>Characteristics</i>	Merkmale	10
1.2	Designazione	<i>Designation</i>	Bezeichnung	11
1.3	Selezione	<i>Selection</i>	Getriebeauswahl	11
1.4	Verifica termica	<i>Temperature check</i>	Temperaturprüfung	12
1.5	Gioco angolare	<i>Backlash</i>	Winkelspiel	12
1.6	Carichi radiali e assiali su albero lento	<i>Radial and axial loads on output shaft</i>	Radial-und Axiallasten an der Ausgangswelle	15
1.7	Lubrificazione	<i>Lubrication</i>	Schmierung	15
1.8	Momento d'inerzia	<i>Moments of inertia</i>	Trägheitsmoment	16
1.9	Dati tecnici	<i>Technical data</i>	Technische Daten	18
1.10	Dimensioni	<i>Dimensions</i>	Abmessungen	18
1.11	Istruzioni per il montaggio del motore	<i>Instructions for the motor assem- bling</i>	Anleitung für Motoranbau	26



1.1 Caratteristiche

La serie di riduttori epicicloidali REP è il risultato di un ottimo rapporto tra economicità del prezzo e garanzia di precisione delle caratteristiche di funzionamento. I nostri riduttori sono stati realizzati per un'utilizzo prevalente sulle seguenti applicazioni:

- Macchine utensili
- Macchine per la lavorazione del legno
- Linee transfer
- Macchine da stampa
- Macchine automatiche per confezionamento ed imballaggio
- Automazioni
- Manipolatori
- Macchine serigrafiche
- Guide lineari

La gamma dei riduttori REP è costituita da 4 grandezze (075, 100, 125 e 150), a 1, 2 e 3 stadi di riduzione, ognuna con due o tre tipi di alberi uscita (AU...) e flange uscita di tipo FLT e FLQ.

Corpo: costruito in acciaio speciale da nitrurazione, garantisce robustezza e una elevata affidabilità nel tempo.

Flange: le flange in entrata ed in uscita sono costruite in alluminio e sono disponibili in molteplici varianti costruttive.

Alberi: sono costruiti in acciaio legato bonificato.

Ingranaggi: in acciaio legato da cementazione e tempra, con dentature rettificata.

Cuscinetti: di elevata qualità opportunamente dimensionati per garantire elevate durate e silenziosità di funzionamento.

1.1 Characteristics

The planetary gearbox REP series is the result of the outstanding combination competitive price / precision guaranteed with regard to operating features. Our gearboxes are manufactured for prevailing utilization in the following applications:

- *Machine tools*
- *Woodworking machines*
- *Transfer machines*
- *Printing machines*
- *Automatic packing & packaging machines*
- *Automations*
- *Mechanical hands*
- *Silk-screen process machines*
- *Linear guides*

The REP series is available in 4 sizes (075, 100, 125 and 150), with 1, 2 or 3 reduction stages, with two or three types of output shaft (AU...) and two types of output flange (FLT and FLQ).

Housing: made of special nitrated steel to assure strength, high reliability and long life.

Flanges: input and output flanges made of aluminium and available in several versions.

Shafts: made of hardened and tempered alloy steel.

Gears: made of casehardened and tempered alloy steel, with ground toothings.

Bearings: high quality and suitably sized to assure long life and noiseless working.

1.1 Merkmale

Die REP Serie von Planetengetrieben ist das Ergebnis des hervorragenden Beziehung guter Preis / garantierte Präzision der Betriebseigenschaften. Unsere Getriebe sind für überwiegende Verwendung in der folgenden Applikationen hergestellt:

- Werkzeugmaschinen
- Holzbearbeitungsmaschinen
- Transfermaschinen
- Druckmaschinen
- Automatische Verpackungsmaschinen
- Automation
- Manipulatoren
- Siebdruckmaschinen
- Linearführungen

Die REP Serie ist in 4 Größen (075, 100, 125 und 150) mit 1, 2 oder 3 Untersetzungsstufen, mit zwei oder drei Typen von Abtriebswellen (AU...) und zwei Typen von Abtriebsflanschen (FLT und FLQ) verfügbar.

Gehäuse: aus Spezial-Nitrierstahl. Garantiert Robustheit und dauerhaft hohe Zuverlässigkeit.

Ein- u. Ausgangsflansche: aus Aluminium, in zahlreichen Varianten lieferbar.

Wellen: aus vergütetem Legierungsstahl.

Zahnräder: aus gehärteten Einsatzstahl mit geschliffenen Zahnflanken.

Lager: sind hochwertig und zweckmäßig bemessen, um eine lange Lebensdauer und einen geräuscharmen Lauf zu garantieren.

1.2 Designazione

1.2 Designation

1.2 Bezeichnung

Riduttore epicicloidale <i>Planetary gearbox</i> Planetengetriebe	Grandezza Size Größe	Numero di stadi Steps Unteretzungsstufen	Coassiale Coaxial Koaxial	Rapporto di riduzione Ratio Unteretzungsverhältnis	Albero uscita <i>Output shaft</i> Durchmesser Abtriebswelle	Flangia uscita <i>Output flange</i> Ausgangsfiansch	Albero entrata <i>Input shaft</i> Durchmesser Eingangswelle	Flangia in entrata <i>Input flange</i> Eingangsfiansch	Posizione di montaggio <i>Mounting position</i> Baulage
REP	075	2	C	100	AU16	FLT	AE12	P03	B5
	075 100 125 150	1 2 3	C	3 - 343	Vedi tabelle <i>See tables</i> Siehe Tab.	FLT FLQ	Vedi tabelle <i>See tables</i> Siehe Tab.	Vedi tabelle <i>See tables</i> Siehe Tab.	B5 V1 V3 OS

2.3 Selezione

2.3 Selection

2.3 Getriebeauswahl

Per la selezione dei riduttori epicicloidali REP, seguire la procedura descritta al paragrafo a pag. 6

Make the selection of the planetary gearboxes REP Series as described at paragraph page 6.

Die Wahl der Planetengetriebe Serie REP wird wie im Abschnitt Seite 6.

1.4 Verifica termica

Si deve individuare il valore del momento torcente massimo / potenza massima, applicabile, in modo continuativo, in ingresso al riduttore epicicloidale, tale per cui la temperatura del riduttore stesso non superi $T_{max}=95^{\circ}C$ (massimo valore di temperatura raggiungibile nel caso di applicazioni standard). Tali valori devono risultare maggiori rispetto al momento torcente / potenza realmente applicati.

I massimi valori di coppia motrice / potenza applicabili in entrata al riduttore, in servizio continuativo, sono ricavabili dalle seguenti tabelle (tab. 2, tab. 3), in funzione del numero di stadi di riduzione e del numero di giri in entrata, considerata una temperatura ambiente $T_0=20^{\circ}C$.

1.4 Temperature check

It is necessary to determine the max. torque/max. power applicable at the planetary gearbox input, continuous duty, so that gearbox temperature does not exceed $T_{max}=95^{\circ}C$ (maximum permitted temperature for standard applications). The max applicable values have to be higher than the torque/power actually applied. The maximum values of driving torque/power applicable at gearbox input, continuous duty, are listed in the following tables (table 2 and 3), depending on number of reduction stages, number of revolutions at input and considering an ambient temperature $T_0 = 20^{\circ}C$.

1.4 Temperaturprüfung

Es muss berechnet werden, welches Maximaldrehmoment /welche Maximalleistung am Antrieb des Planetengetriebes im Dauerbetrieb angewendet werden darf, ohne dass die Getriebetemperatur über $T_{max}=95^{\circ}C$ steigt (zulässige Maximaltemperatur bei Standardanwendungen). Der berechnete Wert muss höher als der wirklich angewendete Wert die maximal Werte von Drehmoment / Leistung sein.

Die Maximalwerte von Drehmoment / Leistung (Dauerbetrieb) werden in den folgenden Tabellen (Tab.2 und Tab.3) angegeben. Die Werte hängen von Zahl der Übersetzungsstufen und der Umdrehungen am Antrieb ab dabei wird eine Umgebungstemperatur $T_0=20^{\circ}C$ berücksichtigt.

Potenza / Power / Leistung [kW]
(Limite termico / Thermal capacities / Temperaturgrenze)

Tab. 2	Stadi Steps Stufenzahl	n_1 [min ⁻¹]			
		900	1400	2800	3600
REP 75	1	4.5	4.4	4.0	3.5
	2	2.5	2.3	2.0	1.8
	3	1.9	1.8	1.5	1.4
REP 100	1	6.0	6.0	4.6	3.8
	2	3.5	3.3	2.5	2.0
	3	2.7	2.5	2.0	1.6
REP 125	1	9.0	8.5	6.2	4.7
	2	5.5	4.8	3.4	2.5
	3	4.0	3.7	2.8	2.0
REP 150	1	11.0	10.0	5.6	2.8
	2	6.1	5.5	2.6	1.0
	3	4.7	4.3	2.3	0.9

Coppia / Torque / Drehmoment [Nm]
(Limite termico / Thermal capacities / Temperaturgrenze)

Tab. 3	Stadi Steps Stufenzahl	n_1 [min ⁻¹]			
		900	1400	2800	3600
REP 75	1	48	30	14	9
	2	27	16	7	5
	3	20	12	5	4
REP 100	1	64	41	16	10
	2	37	23	9	5
	3	29	17	7	4
REP 125	1	96	58	21	12
	2	58	33	12	7
	3	42	25	10	5
REP 150	1	117	68	19	7
	2	65	38	9	3
	3	50	29	8	2

Nel caso in cui l'applicazione preveda l'utilizzo di una coppia motrice / potenza maggiore del valore limite riportato nella tabella precedente, occorre valutare il massimo tempo di utilizzo, t_{max} (s), del riduttore, in servizio continuo, affinché la temperatura non superi il valore $T_{max}=95^{\circ}C$.

A tal fine: il massimo tempo di utilizzo, t_{max} , è ricavabile dalla seguente relazione:

In case the application requires a driving torque/power higher than the max. permitted values reported in the table above, it is necessary to calculate the maximum length of operation, t_{max} (s), of the gearbox in continuous duty so that temperature does not exceed $T_{max}=95^{\circ}C$.

The max. duration of operation, t_{max} , is to be calculated as follows:

Falls der verlangte Wert von Drehmoment / Leistung höher als der in den o.g. Tabellen angegebenen Wert ist, ist es notwendig, die maximale Anwendungsdauer t_{max} (s) im Dauerbetrieb zu bestimmen, damit die Temperatur unter $T_{max}=95^{\circ}C$ bleibt.

Die maximale Anwendungsdauer t_{max} ist wie folgt zu berechnen:

$$t_{max} = -\tau_c \cdot \ln \frac{T_s - T_{MAX}}{T_s - T_0} \quad [s]$$

Dove :

T_{MAX} = 95 °C (temperatura massima raggiungibile dal riduttore)
 T_0 = temperatura ambiente (°C)
 τ_c = costante di tempo (s) ricavabile consultando la seguente tabella (Tab. 4):

Where:

T_{MAX} = 95 °C (maximum permitted temperature)
 T_0 = ambient temperature (°C)
 τ_c = time constant (s), as reported in the following table (Tab. 4):

Wobei:

T_{MAX} = 95 °C (zulässige Maximaltemperatur des Getriebes)
 T_0 = Umgebungstemperatur (°C)
 τ_c = Zeitkonstante, aus der folgenden Tabelle erhältlich (Tab. 4):

	REP 75			REP 100			REP 125			REP 150		
Stadi / Steps / Stufenzahl	1	2	3	1	2	3	1	2	3	1	2	3
τ_c (s)	Costante di tempo / Time constant / Zeitkonstante											
	551	655	748	747	939	1111	1255	1590	1891	1858	2369	2824

T_s = temperatura massima (°C) alla quale il riduttore tenderà a stabilizzarsi nel caso in cui sia applicata in ingresso la potenza P1, in condizioni di funzionamento continuo. Il valore di T_s è ricavabile dalla seguente formula:

T_s = maximum temperature (°C) at which the gearbox will tend to stabilize in case P1 power is applied at input, continuous duty. Calculate T_s value with the following formula:

T_s = maximale Temperatur (C°), auf die das Getriebe sich stabilisieren wird, falls im Dauerbetrieb P1 Antriebsleistung angewendet wird. T_s ist mit der folgenden Formel zu berechnen:

$$T_s = T_0 + \frac{P_0 + P_{\eta}}{C \cdot f_v} \quad [^{\circ}\text{C}]$$

in cui:

P_0 = potenza persa a vuoto (W), ricavabile dalla seguente tabella (Tab. 5) in funzione della grandezza del riduttore, del numero degli stadi di riduzione e della velocità di rotazione in ingresso

Where:

P_0 = loadless friction power (W), reported in the following table (Tab. 5), depending on gearbox size, number of reduction stages and input rotation speed

Wobei:

P_0 = Verlustleistung ohne Last (W), ist aus der folgenden Tabelle zu entnehmen und hängt von Getriebegröße, Stufenzahl und Antriebsdrehzahl ab.

	$n_1 = 900$ [min ⁻¹]			$n_1 = 1400$ [min ⁻¹]			$n_1 = 2800$ [min ⁻¹]			$n_1 = 3600$ [min ⁻¹]		
	Stadi / Steps / Stufenzahl											
	1	2	3	1	2	3	1	2	3	1	2	3
	P_0 - Potenza persa a vuoto / Loadless friction power / Verlustleistung ohne Last [W]											
REP 75	3	4	5	6	8	8	14	18	19	20	26	27
REP 100	7	9	9	12	15	16	30	38	39	42	53	55
REP 125	12	15	16	22	27	28	56	71	73	81	101	104
REP 150	22	27	28	39	50	51	106	132	136	151	191	196

C = Coefficiente di dispersione termica, ricavabile dalla seguente tabella (Tab.6), in funzione della grandezza del riduttore

C = loss of heat coefficient, listed in the following table (Tab. 6), according to gearbox size.

C = Wärmeverlustkoeffizient, wird in der folgenden Tabelle (Tab.6) angegeben und hängt von Getriebegröße ab.

	Stadi / Steps / Stufenzahl		
	1	2	3
	C - Coefficiente di dispersione termica / loss of heat coefficient / Wärmeverlustkoeffizient		
REP 75	1.024	1.120	1.248
REP 100	1.410	1.620	1.800
REP 125	2.175	2.450	2.725
REP 150	2.680	3.020	3.380

f_v = fattore di ventilazione
1.45 con ventilazione forzata efficace con ventola dedicata
1.25 con ventilazione forzata secondaria ad altri dispositivi (pulegge, ventole motore, ecc.)

f_v = ventilation factor
1.45 for forced ventilation effective with special fan
1.25 for forced ventilation secondary to other devices (pulleys, motor fans, etc.)

f_v = Lüftungsfaktor
1.45 für wirksame Drücklüftung mit Sonderlaufrad
1.25 für Drücklüftung zweitrangig zu anderen Vorrichtungen (Scheiben, Motorlaufräder, u.s.w.)

1 refrigerazione naturale (situazione standard)
0.5 in ambiente chiuso e ristretto (carter)

1 for natural cooling (standard situation)
0.5 in a close and narrow place (housing)

1 für Naturlüftung (Standardsituation)
0.5 in geschlossenem und engem Raum (Gehäuse)

P_{η} = potenza persa proporzionale alla potenza applicata (W)
P1 . 0.015 (W) nel caso di 1 stadio di riduzione
P1 . 0.03 (W) nel caso di 2 stadi di riduzione
P1 . 0.044 (W) nel caso di 3 stadi di riduzione

P_{η} = friction power proportional to the applied power (W)
P1 . 0.015 (W) in case of 1 reduction stage
P1 . 0.03 (W) in case of 2 reduction stages
P1 . 0.044 (W) in case of 3 reduction stages

P_{η} = Verlustleistung proportional zu der angewandten Leistung (W)
P1 . 0.015 (W) im Falle von 1 Übersetzungsstufe
P1 . 0.03 (W) im Falle von 2 Übersetzungsstufen
P1 . 0.044 (W) im Falle von 3 Übersetzungsstufen

P1 è la potenza applicata in ingresso, da esprimersi in W. Nel caso in cui sia invece nota la coppia motrice applicata in ingresso T1, in Nm, si ricava il corrispondente valore di potenza, attraverso la relazione:

P1 is the power applied at gearbox input and is expressed in W. In case one only knows T1 (driving torque applied at input) expressed in Nm, the corresponding power value can be obtained as follows:

P1 ist die am Getriebeantrieb angewandte Leistung und wird in W ausgedrückt. Falls nur T1 (Antriebsdrehmoment in Nm) bekannt ist, dann ist den entsprechenden Leistungswert mit der folgenden Formel zu berechnen:

$$P1 = \frac{T1 \cdot n_1}{9550} \cdot 1000 \text{ [W]}$$

con n_1 velocità di rotazione in ingresso in min^{-1} .

Se il ciclo di lavoro è variabile nel tempo, si determinino i valori della coppia media $T1_E$ e velocità media in ingresso $n1_E$ secondo le seguenti formule:

where n_1 is the input rotation speed in min^{-1} .

If the operation cycle changes in time, the values of $T1_E$ (average torque) and $n1_E$ (average input speed) can be determined with the following formulae:

Dabei ist n_1 die Antriebsdrehzahl in min^{-1} . Falls der Betriebszyklus in Laufe der Zeit wechselnd ist, dann sind Durchschnittsdrehmoment $T1_E$ und Durchschnittsdrehzahl am Antrieb $n1_E$ mit der folgenden Formel zu berechnen:

$$T1_E = \sqrt[3]{\frac{T1_{MAX}^3 \cdot n_{1m} \cdot ta + \dots + T1_n^3 \cdot n_{1n} \cdot tn}{ta \cdot n_{1m} + \dots + tn \cdot n_{1n}}} \text{ [Nm]}$$

$T1_n, n1_n, t_n$ = valori riferiti allo step ennesimo
 = values referred to nth step.
 = Werte mit Bezug auf n-te Stufe.

$$n1_E = \frac{n_{1m} \cdot ta + \dots + n_{1n} \cdot tn}{ta + \dots + tn} \text{ [min}^{-1}\text{]}$$

1.5 Gioco Angolare (α_{max})

Gioco massimo [arcmin] misurato sull'albero uscita, con albero entrata bloccato applicando una coppia pari al 2% della coppia nominale.

1.5 Backlash (α_{max})

Max. backlash measured on output shaft with torque equal to 2% of the nominal torque value with input shaft blocked

1.5 Winkelspiel (α_{max})

Maximales Winkelspiel [arcmin], gemessen an der Abtriebswelle bei blockierter Eingangswelle mit Drehmoment gleich 2% des Nennmoments.

1.6 Carichi radiali e assiali su albero lento

Nella tabella delle prestazioni sono indicati i valori, espressi in N, dei carichi assiali e radiali ammissibili alle diverse velocità per una durata dei cuscinetti di 20000 ore. Il carico radiale F_{R2} si considera applicato ad una distanza dalla battuta pari alla metà della lunghezza dell'albero lento. Per distanze y diverse, è possibile calcolare il nuovo carico massimo ammissibile F_{R2Y} utilizzando formula e coefficienti indicati nella tabella.

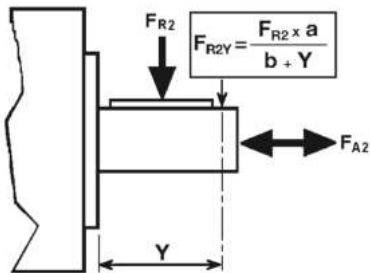

1.6 Radial and axial loads on output shaft

The table of performances shows admissible axial and radial load values expressed in N for different speeds and for a bearing life of 20000 hours. Radial load F_{R2} calculations have been based on loads applied to halfway the output shaft extension. For different y distance it is possible to calculate the new maximum admissible load by using formula and coefficient shown in the table.

1.6 Radial- und axiallast an der Ausgangswelle

Die Leistungstabelle enthält die in N ausgedrückten Werte der Axial- und Radiallasten für verschiedene Umdrehungszahlen. Diesen Werten liegt eine Lebensdauer der Lager von 20000 Stunden zugrunde. Die Radiallast F_{R2} greift hierbei auf der Mitte der Abtriebswelle an. Falls Y -distanz anders ist, ist die Zulässige radiallast F_{R2Y} mit den in der Tabelle angegebenen formel und Koeffizient zu berechnen:

	REP 75	REP 100	REP 125	REP 150
a	46	55	85	102
b	30	37	51	61

1.7 Lubrificazione

I riduttori REP sono forniti completi di lubrificante a vita pertanto non necessitano di manutenzione. In fase di ordine specificare la posizione di montaggio.

1.7 Lubrication

REP gearboxes are supplied filled with long-life lubricant and do not require any maintenance. When ordering it is important to specify the exact mounting position.

1.7 Schmierung

Die REP Planetengetriebe werden inklusiv Dauerschmierung geliefert und sind wartungsfrei. Bei der Bestellung bitte die Einbauposition angeben

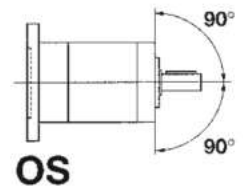
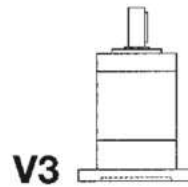
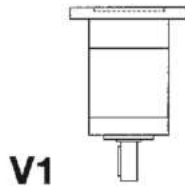
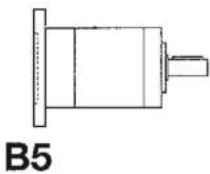

1.8 Momento d'inerzia J
[kg·cm²]

1.8 Moment of inertia J
[kg·cm²]

1.8 Trägheitsmoment J
[kg·cm²]

REP 075											
Albero entrata / Input shaft / Antriebswelle											
Stadi Steps Stufenzahl	i	6	6.35	7	8	9	9.52	11	12	12.7	14
1	3	0.16	0.16	0.16	0.19	0.19	0.19	0.21	0.21	0.21	0.25
	4	0.14	0.14	0.14	0.16	0.16	0.16	0.18	0.19	0.18	0.22
	5	0.12	0.12	0.12	0.14	0.14	0.14	0.16	0.16	0.16	0.20
	6	0.11	0.11	0.11	0.13	0.13	0.13	0.15	0.16	0.16	0.19
2	9	0.16	0.16	0.16	0.19	0.19	0.19	0.21	0.21	0.21	0.25
	12	0.16	0.16	0.16	0.19	0.19	0.18	0.21	0.21	0.21	0.25
	16	0.14	0.14	0.14	0.16	0.16	0.16	0.18	0.18	0.18	0.22
	20	0.12	0.12	0.12	0.14	0.14	0.14	0.16	0.16	0.16	0.20
	24	0.11	0.11	0.11	0.13	0.13	0.13	0.15	0.16	0.15	0.19
	30	0.11	0.11	0.11	0.13	0.13	0.13	0.15	0.16	0.15	0.19
3	36	0.11	0.11	0.11	0.13	0.13	0.13	0.15	0.16	0.15	0.19
	27	0.16	0.16	0.16	0.19	0.19	0.19	0.21	0.21	0.21	0.25
	36	0.16	0.16	0.16	0.19	0.19	0.19	0.21	0.21	0.21	0.25
	48	0.16	0.16	0.16	0.19	0.19	0.18	0.21	0.21	0.21	0.25
	64	0.14	0.14	0.14	0.16	0.16	0.16	0.18	0.18	0.18	0.22
	80	0.12	0.12	0.11	0.14	0.14	0.14	0.16	0.16	0.16	0.20
	100	0.11	0.11	0.11	0.14	0.14	0.14	0.16	0.16	0.16	0.20
	120	0.11	0.11	0.11	0.13	0.13	0.13	0.15	0.16	0.15	0.19
	144	0.11	0.11	0.11	0.13	0.13	0.13	0.15	0.16	0.15	0.19
	180	0.11	0.11	0.11	0.13	0.13	0.13	0.15	0.16	0.15	0.19
216	0.11	0.11	0.11	0.13	0.13	0.13	0.15	0.16	0.15	0.19	

REP 100									
Albero entrata / Input shaft / Antriebswelle									
Stadi Steps Stufenzahl	i	9	9.52	11	12.7	14	15.87	16	19
1	3	0.47	0.47	0.49	0.49	0.53	0.82	0.82	0.80
	4	0.35	0.35	0.37	0.37	0.41	0.70	0.70	0.69
	5	0.28	0.28	0.30	0.30	0.34	0.63	0.63	0.62
	6	0.26	0.26	0.28	0.28	0.32	0.61	0.61	0.60
2	9	0.48	0.48	0.50	0.51	0.55	0.83	0.83	0.82
	12	0.47	0.47	0.49	0.49	0.53	0.82	0.82	0.81
	16	0.34	0.34	0.36	0.36	0.41	0.69	0.69	0.68
	20	0.28	0.28	0.30	0.30	0.34	0.63	0.63	0.62
	24	0.26	0.26	0.28	0.28	0.32	0.61	0.61	0.59
	30	0.25	0.25	0.27	0.28	0.32	0.61	0.60	0.59
3	36	0.25	0.25	0.27	0.28	0.32	0.60	0.60	0.59
	27	0.49	0.49	0.51	0.51	0.55	0.84	0.84	0.82
	36	0.48	0.48	0.50	0.51	0.55	0.84	0.83	0.82
	48	0.47	0.47	0.49	0.49	0.53	0.82	0.82	0.81
	64	0.34	0.34	0.36	0.36	0.41	0.69	0.69	0.68
	80	0.28	0.28	0.30	0.30	0.34	0.63	0.63	0.62
	100	0.28	0.27	0.30	0.30	0.34	0.63	0.63	0.61
	120	0.25	0.25	0.27	0.28	0.32	0.61	0.60	0.59
	144	0.25	0.25	0.27	0.28	0.32	0.60	0.60	0.59
	180	0.25	0.25	0.27	0.28	0.32	0.60	0.60	0.59
216	0.25	0.25	0.27	0.28	0.32	0.60	0.60	0.59	

I valori dei momenti d'inerzia riportati si riferiscono all'albero entrata.

The moment of inertia values refer to the input shaft.

Die Werte der Trägheitsmoment beziehen sich auf die Antriebswelle.



1.8 Momento d'inerzia J
[kg·cm²]

1.8 Moment of inertia J
[kg·cm²]

1.8 Trägheitsmoment J
[kg·cm²]

		REP 125							
		Albero entrata / Input shaft / Antriebswelle							
Stadi Steps Stufenzahl	i	12.7	14	15.87	16	19	22	24	28
1	3	1.91	1.98	2.26	2.26	2.24	4.95	4.91	5.10
	4	1.18	1.25	1.53	1.53	1.50	4.22	4.18	4.36
	5	0.84	0.91	1.19	1.19	1.16	3.88	3.84	4.02
	7	0.64	0.70	0.99	0.99	0.96	3.67	3.63	3.82
2	9	1.93	1.99	2.28	2.28	2.25	4.97	4.92	5.11
	12	1.85	1.91	2.20	2.20	2.17	4.88	4.84	5.03
	16	1.14	1.21	1.49	1.49	1.47	4.18	4.14	4.33
	20	0.82	0.88	1.17	1.16	1.14	3.85	3.81	4.00
	28	0.62	0.69	0.97	0.97	0.95	3.66	3.62	3.81
	35	0.63	0.69	0.98	0.98	0.95	3.66	3.62	3.81
3	49	0.62	0.69	0.97	0.97	0.95	3.66	3.62	3.81
	36	1.92	1.99	2.27	2.27	2.24	4.96	4.92	5.11
	48	1.84	1.91	2.19	2.19	2.17	4.88	4.84	5.03
	64	1.14	1.21	1.49	1.49	1.46	4.18	4.14	4.32
	80	0.81	0.88	1.16	1.16	1.14	3.85	3.81	4.00
	100	0.80	0.87	1.15	1.15	1.12	3.84	3.80	3.98
	140	0.62	0.68	0.97	0.97	0.94	3.65	3.61	3.80
	196	0.61	0.68	0.96	0.96	0.94	3.65	3.61	3.80
245	0.61	0.68	0.96	0.96	0.93	3.65	3.61	3.79	
343	0.61	0.68	0.96	0.96	0.93	3.65	3.61	3.79	

		REP 150								
		Albero entrata / Input shaft / Antriebswelle								
Stadi Steps Stufenzahl	i	15.87	16	19	22	24	28	32	35	38
1	3	6.58	6.58	6.62	7.57	7.53	11.55	13.38	13.28	12.94
	4	4.64	4.64	4.68	5.63	5.59	9.62	11.44	11.34	11.00
	5	3.64	3.64	3.68	4.63	4.59	8.62	10.45	10.35	10.01
	7	3.05	3.05	3.09	4.04	4.00	8.03	9.86	9.76	9.42
2	9	6.54	6.54	6.58	7.53	7.49	11.51	13.34	13.24	12.90
	12	6.32	6.32	6.36	7.31	7.27	11.30	13.13	13.03	12.69
	16	4.49	4.49	4.53	5.48	5.44	9.47	11.30	11.20	10.86
	20	3.55	3.55	3.59	4.54	4.50	8.53	10.36	10.26	9.92
	28	3.01	3.01	3.05	4.00	3.96	7.98	9.81	9.71	9.37
	35	2.99	2.99	3.03	3.97	3.94	7.96	9.79	9.69	9.35
3	49	2.97	2.97	3.01	3.96	3.92	7.95	9.78	9.68	9.34
	36	6.51	6.51	6.55	7.50	7.46	11.49	13.31	13.21	12.87
	48	6.31	6.31	6.35	7.29	7.26	11.28	13.11	13.01	12.67
	64	4.49	4.48	4.52	5.47	5.44	9.46	11.29	11.19	10.85
	80	3.55	3.54	3.59	4.53	4.50	8.52	10.35	10.25	9.91
	100	3.51	3.51	3.55	4.50	4.46	8.48	10.31	10.21	9.87
	140	2.98	2.98	3.02	3.97	3.93	7.96	9.79	9.69	9.35
	196	2.97	2.97	3.01	3.96	3.92	7.95	9.78	9.68	9.34
245	2.97	2.97	3.01	3.96	3.92	7.95	9.78	9.68	9.34	
343	2.97	2.97	3.01	3.96	3.92	7.95	9.78	9.68	9.34	

I valori dei momenti d'inerzia riportati si riferiscono all'albero entrata.

The moment of inertia values refer to the input shaft.

Die Werte der Trägheitsmoment beziehen sich auf die Antriebswelle.

1.9 Dati tecnici

1.9 Technical data

1.9 Technische Daten

Stadi Steps Stufenzahl	1				2								3									
i	3	4	5	6	9	12	16	20	24	30	36	27	36	48	64	80	100	120	144	180	216	
n _{1 nom}	4000				4500								5000									
n _{1 max}	6000																					
T _{2N}	35	45	35	30	40	50	50	50	50	40	35	40	55	55	55	55	55	55	55	40	35	
T _{2A}	55	65	55	50	60	70	70	70	70	60	55	60	80	80	80	80	80	80	80	60	55	
T _{2S}	110	130	110	100	120	140	140	140	140	120	110	120	150	150	150	150	150	150	150	120	110	
J	Vedi pag. 16 / See page 16 / Siehe auf Seite 16																					
LpA	< 70																					
R _d	0.96				0.93								0.91									
L _h	20000																					
F _{R2}	1400																					
F _{A2}	700																					
R _t	4																					
α _{max}	4'				6'								8'									
Kg	1.3				1.6								1.9									

F_{R2} Carico radiale nominale in uscita [N] a 300min⁻¹
F_{A2} Carico assiale in uscita [N] a 300min⁻¹

Rated output radial load [N] at 300min⁻¹
Output axial load [N] at 300min⁻¹

Nenn-Radiallast an der Abtriebswelle bei 300min⁻¹
 Axiallast an der Abtriebswelle bei 300min⁻¹

1.10 Dimensioni

1.10 Dimensions

1.10 Abmessungen

Dimensioni generali e uscite / General and output dimensions / General-und Abtriebsabmessungen

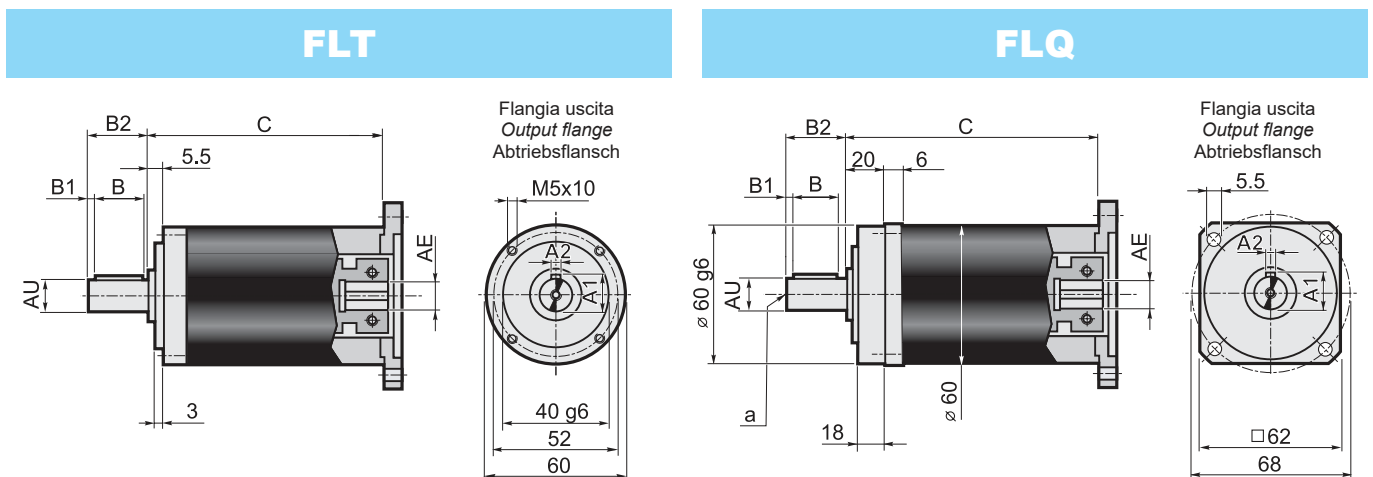

Stadi / Steps / Stufenzahl	1	2	3	
C	86.2	103.9	121.6	AE= 6-6.35-7-8-9-9.52 11-12-12.7-14

	Albero uscita - Output shaft - Abtriebswelle						
	AU j6	A1	A2	B	B1	B2	a
AU12	12	13.5	4	15	3	21	M4x10
AU14	14	16	5	25	2	28	M5x13
AU16	16	18	5	25	2	28	M5x13

Dimensioni entrate / Input dimensions / Antriebsabmessungen

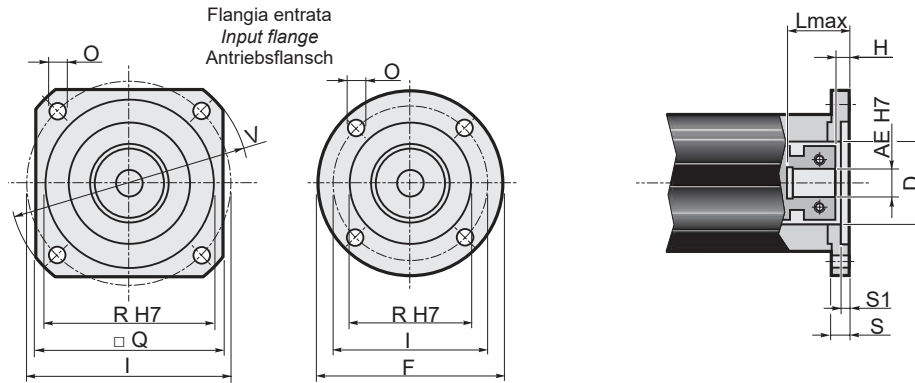

Flange entrata / Input flange / Antriebsflansch										Albero entrata / Input shaft / Antriebswelle																			
										AE																			
F	Q	V	I	R (H7)	O	S	S1	D	6		6.35		7		8		9		9.52		11		12		12.7		14		
									L max	H	L max	H	L max	H	L max	H	L max	H	L max	H	L max	H	L max	H	L max	H	L max	H	L max
P01*	60	=	=	43.82	22	4.5	10	3	22	37	6.5	37	6.5	37	6.5	37	8.5	37	8.5	37	8.5	37	8.5	37	8.5	37	8.5	37	8.5
P02*	=	60	80	66.67	38.1	5.5	10	3	32	37	6.5	37	6.5	37	6.5	37	8.5	37	8.5	37	8.5	37	8.5	37	8.5	37	8.5	37	8.5
P03*	=	60	80	63	40	5.5	10	3.5	32	37	6.5	37	6.5	37	6.5	37	8.5	37	8.5	37	8.5	37	8.5	37	8.5	37	8.5	37	8.5
P04	=	70	90	75	60	6.5	10.5	3.5	32	37	6.5	37	6.5	37	6.5	37	8.5	37	8.5	37	8.5	37	8.5	37	8.5	37	8.5	37	8.5
P05	105	=	=	85	70	6.5	10.5	3.5	32	37	6.5	37	6.5	37	6.5	37	8.5	37	8.5	37	8.5	37	8.5	37	8.5	37	8.5	37	8.5
P06	=	80	110	98.42	73.02	6	11	3.5	35	39	8.5	39	8.5	39	8.5	39	10.5	39	10.5	39	10.5	39	10.5	39	10.5	39	10.5	39	10.5
P07	=	95	120	100	80	6.5	11.5	4	32	41	10.5	41	10.5	41	10.5	41	12.5	41	12.5	41	12.5	41	12.5	41	12.5	41	12.5	41	12.5
P08	=	98	130	115	95	9	11.5	4	32	43.5	13	43.5	13	43.5	13	43.5	15	43.5	15	43.5	15	43.5	15	43.5	15	43.5	15	43.5	15
P09	=	116	160	130	110	9	12	4.5	32	37.5	7	37.5	7	37.5	7	37.5	9	37.5	9	37.5	9	37.5	9	37.5	9	37.5	9	37.5	9
P10*	60	=	=	39	26	4.5	10	3	26	37	6.5	37	6.5	37	6.5	37	8.5	37	8.5	37	8.5	37	8.5	37	8.5	37	8.5	37	8.5
P11*	60	=	=	42	32	4.5	10	3	32	37.5	7	37.5	7	37.5	7	37.5	9	37.5	9	37.5	9	37.5	9	37.5	9	37.5	9	37.5	9
P12*	65	=	=	46	32	4.5	10	3.5	32	37	6.5	37	6.5	37	6.5	37	8.5	37	8.5	37	8.5	37	8.5	37	8.5	37	8.5	37	8.5
P13*	80	=	=	65	50	5.5	10	3.5	32	37	6.5	37	6.5	37	6.5	37	8.5	37	8.5	37	8.5	37	8.5	37	8.5	37	8.5	37	8.5
P14*	60	=	=	39	20	4.5	10	2.5	20	42.5	12	42.5	12	42.5	12	42.5	14	42.5	14	42.5	14	42.5	14	42.5	14	42.5	14	42.5	14
P15	=	75	100	90	60	5.8	12	3.5	32	39	8.5	39	8.5	39	8.5	39	10.5	39	10.5	39	10.5	39	10.5	39	10.5	39	10.5	39	10.5
P16*	60	=	=	45	30	3.5	14	7	30	39	8.5	39	8.5	39	8.5	39	10.5	39	10.5	39	10.5	39	10.5	39	10.5	39	10.5	39	10.5
P17	=	60	82	70	50	4.5	16.5	8	32	37	6.5	37	6.5	37	6.5	37	8.5	37	8.5	37	8.5	37	8.5	37	8.5	37	8.5	37	8.5
P18	=	60	80	60	50	M4	10.5	3.5	32	39	8.5	39	8.5	39	8.5	39	10.5	39	10.5	39	10.5	39	10.5	39	10.5	39	10.5	39	10.5
P19*	60	=	=	36	25	4.5	10	3	25	36	5.5	36	5.5	36	5.5	36	7.5	36	7.5	36	7.5	36	7.5	36	7.5	36	7.5	36	7.5
P20	=	60	82	70	50	5.5	10.5	3.5	32	38	7.5	38	7.5	38	7.5	38	9.5	38	9.5	38	9.5	38	9.5	38	9.5	38	9.5	38	9.5
P21*	60	=	=	46	30	4.5	10	3	30	39	8.5	39	8.5	39	8.5	39	10.5	39	10.5	39	10.5	39	10.5	39	10.5	39	10.5	39	10.5
P22	=	60	80	70.71	36	4.5	10	2	32	38	7.5	38	7.5	38	7.5	38	9.5	38	9.5	38	9.5	38	9.5	38	9.5	38	9.5	38	9.5
P23	=	62	85	70	50	5.5	15.5	3.5	32	37	6.5	37	6.5	37	6.5	37	8.5	37	8.5	37	8.5	37	8.5	37	8.5	37	8.5	37	8.5
P24	=	75	100	90	70	5.8	12	3.5	32	38	7.5	38	7.5	38	7.5	38	9.5	38	9.5	38	9.5	38	9.5	38	9.5	38	9.5	38	9.5
P25	=	70	95	85	55	5.8	12	3.5	32	37	6.5	37	6.5	37	6.5	37	8.5	37	8.5	37	8.5	37	8.5	37	8.5	37	8.5	37	8.5
P26*	=	60	80	65.5	34	5.5	10	3.5	33	41	10.5	41	10.5	41	10.5	41	12.5	41	12.5	41	12.5	41	12.5	41	12.5	41	12.5	41	12.5
P27	=	80	110	95	50	6.5	12	3.5	32	42	11.5	42	11.5	42	11.5	42	13.5	42	13.5	42	13.5	42	13.5	42	13.5	42	13.5	42	13.5
P28	=	60	80	66.67	38.1	M4	9	2.5	32	43.5	13	43.5	13	43.5	13	43.5	15	43.5	15	43.5	15	43.5	15	43.5	15	43.5	15	43.5	15
P29	60	=	=	45	30	M3	11	4	32	38	7.5	38	7.5	38	7.5	38	9.5	38	9.5	38	9.5	38	9.5	38	9.5	38	9.5	38	9.5
P30	=	70	95	85	60	5.8	12	3.5	32	39	8.5	39	8.5	39	8.5	39	10.5	39	10.5	39	10.5	39	10.5	39	10.5	39	10.5	39	10.5
P31	=	62	85	70	50	M4	11	3.5	32	38	7.5	38	7.5	38	7.5	38	9.5	38	9.5	38	9.5	38	9.5	38	9.5	38	9.5	38	9.5
P32	=	60	80	65	40	M5	10	3.5	32	37	6.5	37	6.5	37	6.5	37	8.5	37	8.5	37	8.5	37	8.5	37	8.5	37	8.5	37	8.5
P33	=	85	115	99	60	5.5	11	3.5	32	38	7.5	38	7.5	38	7.5	38	9.5	38	9.5	38	9.5	38	9.5	38	9.5	38	9.5	38	9.5
P34	=	65	87	73.54	40	M4	10	3.5	32	37	6.5	37	6.5	37	6.5	37	8.5	37	8.5	37	8.5	37	8.5	37	8.5	37	8.5	37	8.5
P35	=	60	80	70.71	36	M4	14	2	32	41	10.5	41	10.5	41	10.5	41	12.5	41	12.5	41	12.5	41	12.5	41	12.5	41	12.5	41	12.5
P36	=	85	115	98.42	73.02	6	15	3.5	35	42	11.5	42	11.5	42	11.5	42	13.5	42	13.5	42	13.5	42	13.5	42	13.5	42	13.5	42	13.5
P37	=	95	120	100	80	6.5	16.5	5	32	43.5	13	43.5	13	43.5	13	43.5	15	43.5	15	43.5	15	43.5	15	43.5	15	43.5	15	43.5	15
P38	60	=	=	48	30	M3	11	7	32	38	7.5	38	7.5	38	7.5	38	9.5	38	9.5	38	9.5	38	9.5	38	9.5	38	9.5	38	9.5
P41*	68	=	=	50	30	5.5	10	10	30	37	6.5	37	6.5	37	6.5	37	8.5	37	8.5	37	8.5	37	8.5	37	8.5	37	8.5	37	8.5
P43	=	60	80	66.67	50	M5	9	2.5	32	36	5.5	36	5.5	36	5.5	36	7.5	36	7.5	36	7.5	36	7.5	36	7.5	36	7.5	36	7.5
P44*	60	=	=	32	25	4.5	9	2.5	20	36	5.5	36	5.5	36	5.5	36	7.5	36	7.5	36	7.5	36	7.5	36	7.5	36	7.5	36	7.5
P45	=	62	85	73.54	50	M5	10	3	32	37	6.5	37	6.5	37	6.5	37	8.5	37	8.5	37	8.5	37	8.5	37	8.5	37	8.5	37	8.5
P46	70	=	=	55	45	4.5	9	3	32	36	5.5	36	5.5	36	5.5	36	7.5	36	7.5	36	7.5	36	7.5	36	7.5	36	7.5	36	7.5
P47	=	90	118	104	83	6.5	14	3.5	32	41	10.5	41	10.5	41	10.5	41	12.5	41	12.5	41	12.5	41	12.5	41	12.5	41	12.5	41	12.5
P48	60	=	=	38.88	25	4.5	10	3	25	37	6.5	37	6.5	37	6.5	37	8.5	37	8.5	37	8.5	37	8.5	37	8.5	37	8.5	37	8.5
P49	=	70	90	75	60	M5	10.5	3.5	32	37.5	7	37.5	7	37.5	7	37.5	9	37.5	9	37.5	9	37.5	9	37.5	9	37.5	9	37.5	9

* Per assemblare il motore è necessario smontare la flangia dal riduttore (vedere schema di montaggio 2 a pag. 27).

* Before the mounting of the motor it is necessary to remove the flange from the gearbox (see structural arrangement 2 at the top of the page 27).

* Vor dem Einbauen des Motors soll die Getriebeflangsch abmontiert werden (siehe Bauanleitung 2 auf Seite 27).

1.9 Dati tecnici

1.9 Technical data

1.9 Technische Daten

Stadi Steps Stufenzahl	1				2								3								
i	3	4	5	6	9	12	16	20	24	30	36	27	36	48	64	80	100	120	144	180	216
n _{1 nom}	4000				4500								5000								
n _{1 max}	6000																				
T _{2N}	90	110	90	75	100	115	115	115	115	85	75	100	120	120	120	120	120	120	120	95	80
T _{2A}	145	170	130	120	160	180	180	180	180	140	130	160	190	190	190	190	190	190	190	150	130
T _{2S}	290	340	260	240	320	360	360	360	360	280	260	320	380	380	380	380	380	380	380	300	260
J	Vedi pag. 16 / See page 16 / Siehe auf Seite 16																				
LpA	< 70																				
R _d	0.96				0.93								0.91								
L _h	20000																				
F _{R2}	2100																				
F _{A2}	1050																				
R _t	11																				
α _{max}	4'				6'								8'								
Kg	2.7				3.5								4.3								

F_{R2} Carico radiale nominale in uscita [N] a 300min⁻¹
F_{A2} Carico assiale in uscita [N] a 300min⁻¹

Rated output radial load [N] at 300min⁻¹
Output axial load [N] at 300min⁻¹

Nenn-Radiallast an der Abtriebswelle bei 300min⁻¹
 Axiallast an der Abtriebswelle bei 300min⁻¹

1.10 Dimensioni

1.10 Dimensions

1.10 Abmessungen

Dimensioni generali e uscite / General and output dimensions / General-und Abtriebsabmessungen

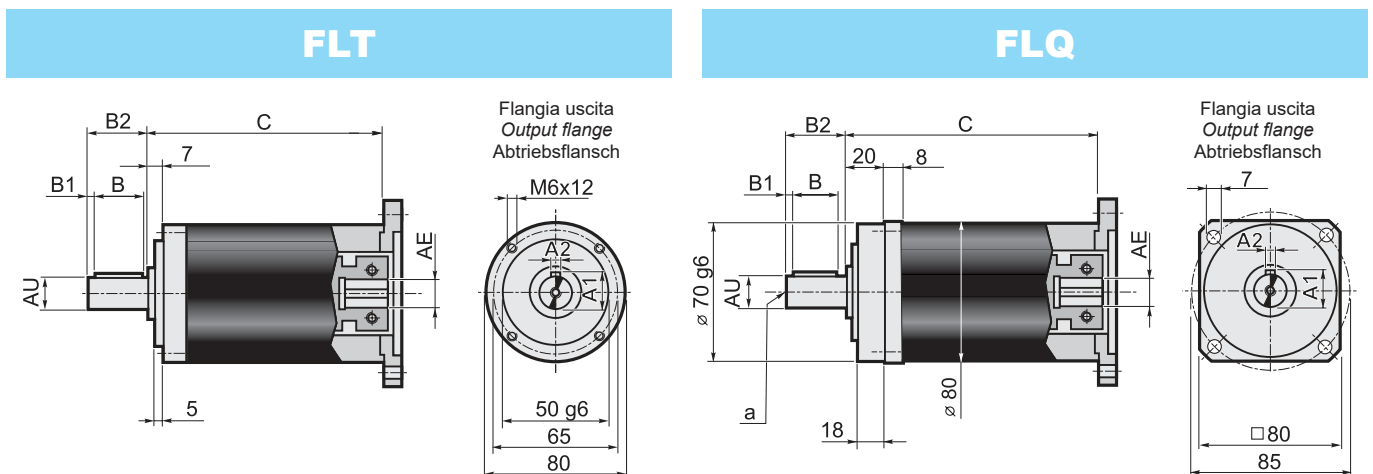

Stadi / Steps / Stufenzahl	1	2	3	
C	102	127	152.5	AE= 9-9.52-11-12.7 14-15.87-16-19

	Albero uscita - Output shaft - Abtriebswelle						
	AU j6	A1	A2	B	B1	B2	a
AU19	19	21.5	6	30	3	36	M6x16
AU22	22	24.5	6	30	3	36	M6x16

Dimensioni entrate / Input dimensions / Antriebsabmessungen

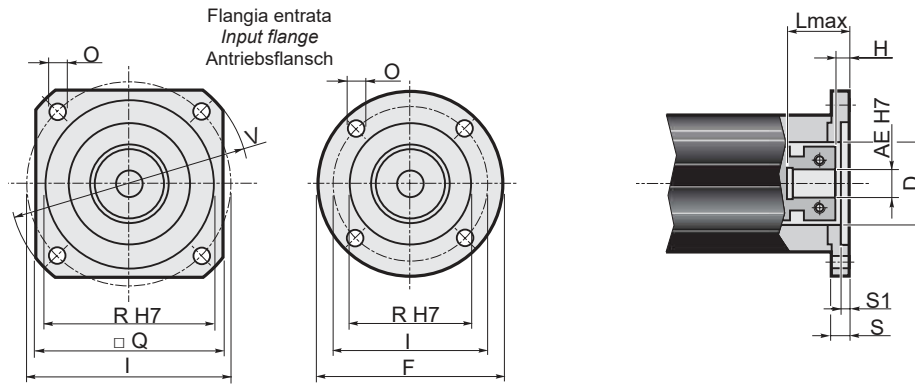

Flange entrata / Input flange / Antriebsflansch										Albero entrata / Input shaft / Antriebswelle																	
										AE																	
										9		9.525		11		12		12.7		14		15.87		16		19	
F	Q	V	I	R (H7)	O	S	S1	D	L _{max}	H	L _{max}	H	L _{max}	H	L _{max}	H	L _{max}	H	L _{max}	H	L _{max}	H	L _{max}	H	L _{max}	H	
P01*	80	=	=	66.67	38.1	5.5	12	3	38.1	41	3.5	41	6	41	6	41	6	41	6	41	6	41	6	41	6	41	6
P02	=	106.5	140	125.72	55.52	7	11	3	45	40	2.5	40	5	40	5	40	5	40	5	40	5	40	5	40	5	40	5
P03*	=	80	90	75	60	5.5	12	3.5	45	41	3.5	41	6	41	6	41	6	41	6	41	6	41	6	41	6	41	6
P04*	105	=	=	85	70	6.5	12	3.5	45	41	3.5	41	6	41	6	41	6	41	6	41	6	41	6	41	6	41	6
P05	=	82.5	110	98.425	73.02	6.5	12	3	45	41	3.5	41	6	41	6	41	6	41	6	41	6	41	6	41	6	41	6
P06	=	90	120	100	80	6.5	13	4	45	42	4.5	42	7	42	7	42	7	42	7	42	7	42	7	42	7	42	7
P07	=	100	135	115	95	8.5	13	4.5	45	42	4.5	42	7	42	7	42	7	42	7	42	7	42	7	42	7	42	7
P08	=	116	160	130	110	9	13	4.5	45	42	4.5	42	7	42	7	42	7	42	7	42	7	42	7	42	7	42	7
P09*	80	=	=	39	26	4.5	12	4	26	41	3.5	41	6	41	6	41	6	41	6	41	6	41	6	41	6	41	6
P10*	80	=	=	65	50	5.5	12	3.5	45	41	3.5	41	6	41	6	41	6	41	6	41	6	41	6	41	6	41	6
P11	=	150	182	166	115	9	32	11	50x14	61	23.5	61	26	61	26	61	26	61	26	61	26	61	26	61	26	61	26
P12*	=	80	105	90	70	6.5	12	3.5	32	41	3.5	41	6	41	6	41	6	41	6	41	6	41	6	41	6	41	6
P14*	105	=	=	90	70	6	19	9	32	48	10.5	48	13	48	13	48	13	48	13	48	13	48	13	48	13	48	13
P15*	80	=	=	70	50	4.5	17	8	45	46	8.5	46	11	46	11	46	11	46	11	46	11	46	11	46	11	46	11
P16	=	142	190	165	130	11	13	4.5	45	42	4.5	42	7	42	7	42	7	42	7	42	7	42	7	42	7	42	7
P17*	80	=	=	63	40	5.5	12	3.5	40	41	3.5	41	6	41	6	41	6	41	6	41	6	41	6	41	6	41	6
P18	=	130	170	145	110	M8	31	7	32	60	22.5	60	25	60	25	60	25	60	25	60	25	60	25	60	25	60	25
P19*	=	80	105	90	60	6.5	12	3.5	32	41	3.5	41	6	41	6	41	6	41	6	41	6	41	6	41	6	41	6
P20*	=	80	105	85	55	5.5	12	3.5	36	41	3.5	41	6	41	6	41	6	41	6	41	6	41	6	41	6	41	6
P21	=	80	110	95	50	M6	12	3.5	45	41	3.5	41	6	41	6	41	6	41	6	41	6	41	6	41	6	41	6
P22	80	=	=	70	50	M4	12	4	45	41	3.5	41	6	41	6	41	6	41	6	41	6	41	6	41	6	41	6
P23	=	80	90	75	60	M5	12	3.5	45	41	3.5	41	6	41	6	41	6	41	6	41	6	41	6	41	6	41	6
P24	80	=	=	46	30	M4	12	4	30	41	3.5	41	6	41	6	41	6	41	6	41	6	41	6	41	6	41	6
P26	80	=	=	65	40	M5	12	3.5	40	41	3.5	41	6	41	6	41	6	41	6	41	6	41	6	41	6	41	3.5
P27	=	80	110	82.02	36.8	M6	14	10	36.8	43	5.5	43	8	43	8	43	8	43	8	43	8	43	8	43	8	43	5.5
P28	=	90	120	100	80	6.5	28	4	45	57	19.5	57	22	57	22	57	22	57	22	57	22	57	22	57	22	57	22
P29*	80	=	=	66.67	50	5.5	12	3	45	41	3.5	41	6	41	6	41	6	41	6	41	6	41	6	41	6	41	6
P30	=	115	155	130	80	9	13	4	45	42	4.5	42	7	42	7	42	7	42	7	42	7	42	7	42	7	42	7
P31*	=	80	105	56	44	M6	14	10	36.8	43	5.5	43	8	43	8	43	8	43	8	43	8	43	8	43	8	43	8
P32	=	80	105	90	70	M6	12	3.5	32	41	3.5	41	6	41	6	41	6	41	6	41	6	41	6	41	6	41	6
P33	=	130	165	145	110	9	13	4.5	45	42	4.5	42	7	42	7	42	7	42	7	42	7	42	7	42	7	42	7
P34	=	90	120	100	80	M6	19	5	45	48	10.5	48	13	48	13	48	13	48	13	48	13	48	13	48	13	48	13
P36	=	100	135	115	95	M8	25	4.5	45	54	16.5	54	19	54	19	54	19	54	19	54	19	54	19	54	19	54	19
P37	=	85	115	98.99	60	M6	12	3.5	32	41	3.5	41	6	41	6	41	6	41	6	41	6	41	6	41	6	41	6
P38	80	=	=	70	50	M5	12	4	45	41	3.5	41	6	41	6	41	6	41	6	41	6	41	6	41	6	41	6
P39	=	90	120	100	80	6.5	13	4.5	45	42	4.5	42	7	42	7	42	7	42	7	42	7	42	7	42	7	42	7
P40	=	80	90	75	60	M6	12	3.5	45	41	3.5	41	6	41	6	41	6	41	6	41	6	41	6	41	6	41	6
P42	=	110	145	125.72	55.5	M8	28	3	45	57	19.5	57	22	57	22	57	22	57	22	57	22	57	22	57	22	57	22
P44*	=	80	105	90	70	6	13	5	32	42	4.5	42	7	42	7	42	7	42	7	42	7	42	7	42	7	42	7
P46	=	100	135	115	95	8.5	17	8	45	46	8.5	46	11	46	11	46	11	46	11	46	11	46	11	46	11	46	11
P47	=	90	120	100	50	M6	12	4.5	45	41	3.5	41	6	41	6	41	6	41	6	41	6	41	6	41	6	41	6

* Per assemblare il motore è necessario smontare la flangia dal riduttore (vedere schema di montaggio 2 a pag. 27).

* Before the mounting of the motor it is necessary to remove the flange from the gearbox (see structural arrangement 2 at the top of the page 27).

* Vor dem Einbauen des Motors soll die Getriebeflange abmontiert werden (siehe Bauanleitung 2 auf Seite 27).

1.9 Dati tecnici

1.9 Technical data

1.9 Technische Daten

Stadi Steps Stufenzahl	1				2								3								
i	3	4	5	7	9	12	16	20	28	35	49	36	48	64	80	100	140	196	245	343	
n _{1 nom}	3000				3500								4000								
n _{1 max}	5000																				
T _{2N}	220	230	200	160	250	260	260	260	260	230	180	280	280	280	280	280	280	280	280	250	200
T _{2A}	350	370	320	300	400	420	420	420	420	370	350	450	450	450	450	450	450	450	450	400	370
T _{2S}	700	750	650	600	800	850	850	850	850	750	700	900	900	900	900	900	900	900	900	800	750
J	Vedi pag. 17 / See page 17 / Siehe auf Seite 17																				
LpA	< 70																				
R _d	0.96				0.93								0.91								
L _h	20000																				
F _{R2}	3700																				
F _{A2}	1850																				
R _t	32																				
α _{max}	4'				6'								8'								
Kg	7.2				9.3								11.4								

F_{R2} Carico radiale nominale in uscita [N] a 300min⁻¹
F_{A2} Carico assiale in uscita [N] a 300min⁻¹

Rated output radial load [N] at 300min⁻¹
Output axial load [N] at 300min⁻¹

Nenn-Radiallast an der Abtriebswelle bei 300min⁻¹
 Axiallast an der Abtriebswelle bei 300min⁻¹

1.10 Dimensioni

1.10 Dimensions

1.10 Abmessungen

Dimensioni generali e uscite / General and output dimensions / General-und Abtriebsabmessungen

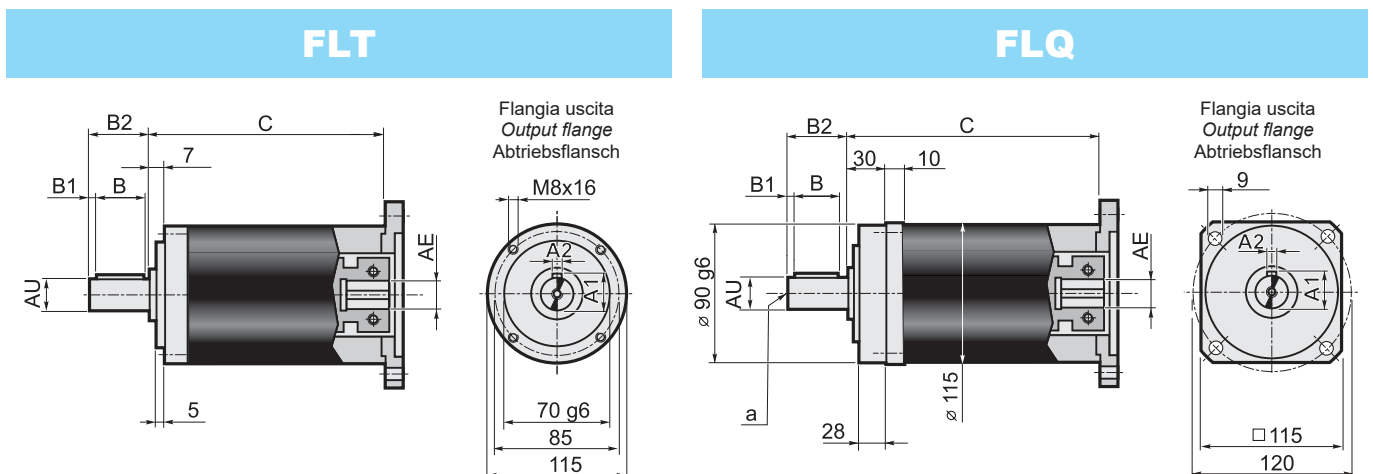

Stadi / Steps / Stufenzahl	1	2	3	
C	126	158.4	191	AE= 12.7-14-15.87-16-19
	145	177	210	AE= 22-24-25-28

	Albero uscita - Output shaft - Abtriebswelle						
	AU j6	A1	A2	B	B1	B2	a
AU25	25	28	8	40	5	50	M8x20
AU32	32	35	10	50	4	58	M10x25

Dimensioni entrate / Input dimensions / Antriebsabmessungen

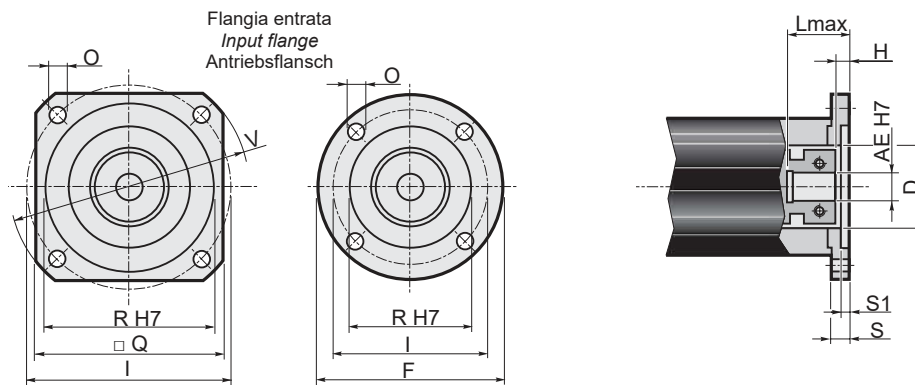

Flange entrata / Input flange / Antriebsflansch										Albero entrata / Input shaft / Antriebswelle																	
										AE																	
										12.7		14		15.87		16		19		22		24		25		28	
F	Q	V	I	R (H7)	O	S	S1	D	L _{max}	H	L _{max}	H	L _{max}	H	L _{max}	H	L _{max}	H	L _{max}	H	L _{max}	H	L _{max}	H			
P01*	=	115	140	125.72	55.52	6.5	13	3	55.52	43	6	43	6	43	6	43	6	43	6	62	6	62	6	62	6	62	6
P02*	115	=	=	75	60	5.5	13	3.5	60	43	6	43	6	43	6	43	6	43	6	62	6	62	6	62	6	62	6
P03*	115	=	=	85	70	6.5	13	3.5	60	43	6	43	6	43	6	43	6	43	6	62	6	62	6	62	6	62	6
P04*	115	=	=	98.42	73.02	6.5	13	3	60	43	6	43	6	43	6	43	6	43	6	62	6	62	6	62	6	62	6
P05*	120	=	=	100	80	6.5	13	4	60	43	6	43	6	43	6	43	6	43	6	62	6	62	6	62	6	62	6
P06*	=	115	140	115	95	9	13	4.5	60	43	6	43	6	43	6	43	6	43	6	62	6	62	6	62	6	62	6
P07	=	115	160	130	110	8.5	13	4.5	60	43	6	43	6	43	6	43	6	43	6	62	6	62	6	62	6	62	6
P08	=	142	190	165	130	11	13	4.5	60	43	6	43	6	43	6	43	6	43	6	62	6	62	6	62	6	62	6
P09	=	192	250	215	180	13	14	4.5	60	44	7	44	7	44	7	44	7	44	7	63	7	63	7	63	7	63	7
P10*	115	=	=	65	50	6.5	13	3.5	50	43	6	43	6	43	6	43	6	43	6	62	6	62	6	62	6	62	6
P11	=	130	170	145	110	M 8	31	7	60	61	24	61	24	61	24	61	24	61	24	80	24	80	24	80	24	80	24
P12	=	130	170	145	110	M 8	17	7	60	47	10	47	10	47	10	47	10	47	10	66	10	66	10	66	10	66	10
P13	=	115	160	130	110	M 8	13	4.5	60	43	6	43	6	43	6	43	6	43	6	62	6	62	6	62	6	62	6
P14*	115	=	=	70	50	6.5	13	3.5	50	43	6	43	6	43	6	43	6	43	6	62	6	62	6	62	6	62	6
P15	115	=	=	90	70	M5	11	3.5	60	41	4	41	4	41	4	41	4	41	4	60	4	60	4	60	4	60	4
P17*	115	=	=	90	70	6.5	13	3.5	60	43	6	43	6	43	6	43	6	43	6	62	6	62	6	62	6	62	6
P18	=	115	155	130	95	8.5	13	4.5	60	43	6	43	6	43	6	43	6	43	6	62	6	62	6	62	6	62	6
P19*	115	=	=	95	50	6.5	13	3.5	50	43	6	43	6	43	6	43	6	43	6	62	6	62	6	62	6	62	6
P20	115	=	=	99	60	M6	13	4	60	43	6	43	6	43	6	43	6	43	6	62	6	62	6	62	6	62	6
P21*	130	=	=	106	82.5	12.5	26.5	15	60	56.5	19.5	56.5	19.5	56.5	19.5	56.5	19.5	56.5	19.5	75.5	19.5	75.5	19.5	75.5	19.5	75.5	19.5
P22	=	144	190	165	110	11	15	4.5	60	45	8	45	8	45	8	45	8	45	8	64	8	64	8	64	8	64	8
P23*	115	=	=	63	40	5.5	11	3.5	40	41	4	41	4	41	4	41	4	41	4	60	4	60	4	60	4	60	4
P24	120	=	=	100	80	M6	18	7	60	48	11	48	11	48	11	48	11	48	11	67	11	67	11	67	11	67	11
P25	=	115	155	115	95	M8	27	4.5	60	57	20	57	20	57	20	57	20	57	20	76	20	76	20	76	20	76	20
P26	=	115	155	131.95	55.52	M8	27	4.5	60	57	20	57	20	57	20	57	20	57	20	76	20	76	20	76	20	76	20
P27	170	=	=	148	114	8.5	13	4	60	43	6	43	6	43	6	43	6	43	6	62	6	62	6	62	6	62	6
P28	=	115	140	115	95	M8	16	6	60	46	9	46	9	46	9	46	9	46	9	65	9	65	9	65	9	65	9
P29	133,5	=	=	121.5	60	M6	13	13	60	43	6	43	6	43	6	43	6	43	6	62	6	62	6	62	6	62	6

* Per assemblare il motore è necessario smontare la flangia dal riduttore (vedere schema di montaggio 2 a pag. 27).

* Before the mounting of the motor it is necessary to remove the flange from the gearbox (see structural arrangement 2 at the top of the page 27).

* Vor dem Einbau des Motors soll die Getriebeflangens abmontiert werden (siehe Bauanleitung 2 auf Seite 27).

1.9 Dati tecnici

1.9 Technical data

1.9 Technische Daten

Stadi Steps Stufenzahl	1				2								3								
i	3	4	5	7	9	12	16	20	28	35	49	36	48	64	80	100	140	196	245	343	
$n_{1\text{ nom}}$	3000				3500								4000								
$n_{1\text{ max}}$	5000																				
T_{2N}	430	470	410	340	500	560	560	560	560	470	370	600	600	600	600	600	600	600	500	450	
T_{2A}	700	750	650	600	800	900	900	900	900	750	700	950	950	950	950	950	950	950	800	750	
T_{2S}	1400	1500	1300	1200	1600	1800	1800	1800	1800	1500	1400	1900	1900	1900	1900	1900	1900	1900	1600	1500	
J	Vedi pag. 17 / See page 17 / Siehe auf Seite 17																				
LpA	< 70																				
R_d	0.96				0.93								0.91								
L_h	20000																				
F_{R2}	6600																				
F_{A2}	3300																				
R_t	60																				
$\alpha_{\text{ max}}$	4'				6'								8'								
Kg	13.0				17.0								21								

F_{R2} Carico radiale nominale in uscita [N] a 300min⁻¹
 F_{A2} Carico assiale in uscita [N] a 300min⁻¹

Rated output radial load [N] at 300min⁻¹
 Output axial load [N] at 300min⁻¹

Nenn-Radiallast an der Abtriebswelle bei 300min⁻¹
 Axiallast an der Abtriebswelle bei 300min⁻¹

1.10 Dimensioni

1.10 Dimensions

1.10 Abmessungen

Dimensioni generali e uscite / General and output dimensions / General-und Abtriebsabmessungen

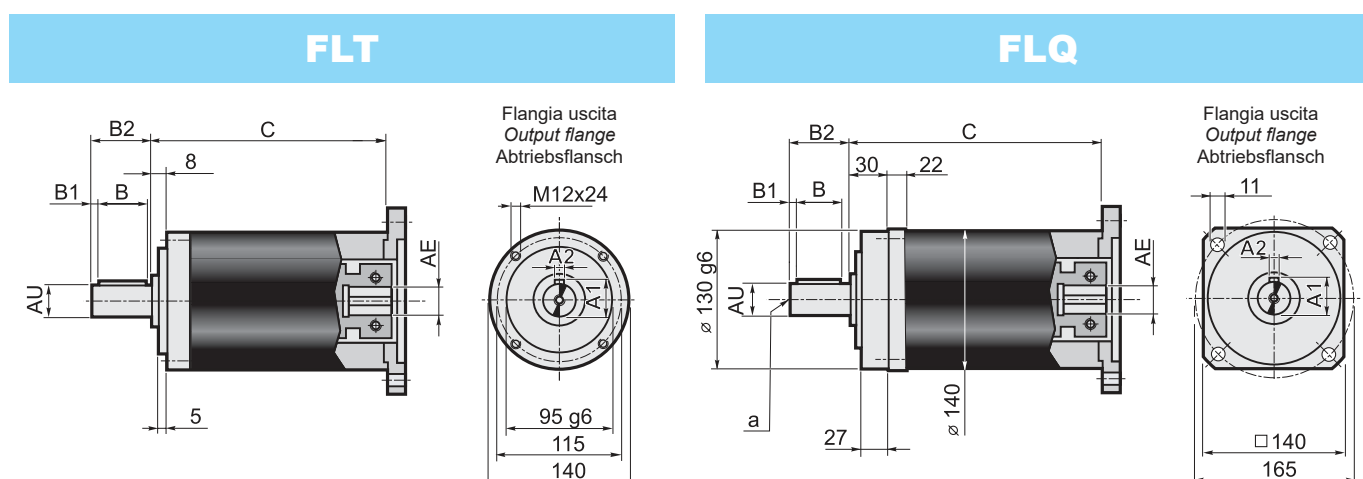

Stadi / Steps / Stufenzahl	1	2	3	
C	160	201	242	AE= 15.87-16-19-22-24
	185	226	267	AE= 28-32-35-38

	Albero uscita - Output shaft - Abtriebswelle						
	AU j6	A1	A2	B	B1	B2	a
AU38	38	41	10	70	5	80	M10x25
AU40	40	43	12	70	5	80	M10x25

Dimensioni entrate / Input dimensions / Antriebsabmessungen

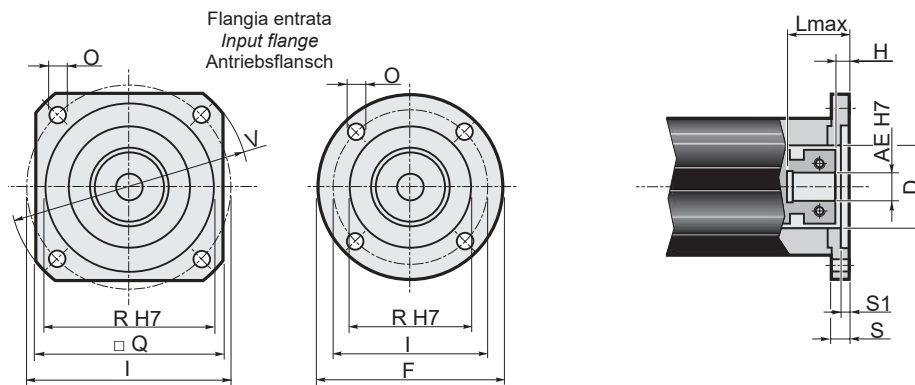

Flange entrata / Input flange / Antriebsflansch										Albero entrata / Input shaft / Antriebswelle																	
										AE																	
										15.87		16		19		22		24		28		32		35		38	
F	Q	V	I	R (H7)	O	S	S1	D	L _{max}	H	L _{max}	H	L _{max}	H	L _{max}	H	L _{max}	H	L _{max}	H	L _{max}	H	L _{max}	H			
P01*	140	=	=	125.72	55.52	6.5	15	4	55.52	57.8	6.8	57.8	6.8	57.8	6.8	57.8	6.8	57.8	6.8	82.8	7.3	82.8	7.3	82.8	7.3	82.8	7.3
P02*	140	=	=	100	80	6.5	15	4	70	57.8	6.8	57.8	6.8	57.8	6.8	57.8	6.8	57.8	6.8	82.8	7.3	82.8	7.3	82.8	7.3	82.8	7.3
P03*	140	=	=	115	95	8.5	15	4.5	70	57.8	6.8	57.8	6.8	57.8	6.8	57.8	6.8	57.8	6.8	82.8	7.3	82.8	7.3	82.8	7.3	82.8	7.3
P04*	=	140	160	130	110	8.5	15	4.5	70	57.8	6.8	57.8	6.8	57.8	6.8	57.8	6.8	57.8	6.8	82.8	7.3	82.8	7.3	82.8	7.3	82.8	7.3
P05	=	142	190	165	130	11	15	4.5	70	57.8	6.8	57.8	6.8	57.8	6.8	57.8	6.8	57.8	6.8	82.8	7.3	82.8	7.3	82.8	7.3	82.8	7.3
P06	=	190	250	215	180	13	15	4.5	70	57.8	6.8	57.8	6.8	57.8	6.8	57.8	6.8	57.8	6.8	82.8	7.3	82.8	7.3	82.8	7.3	82.8	7.3
P07	=	250	300	265	230	13	15	4.5	70	57.8	6.8	57.8	6.8	57.8	6.8	57.8	6.8	57.8	6.8	82.8	7.3	82.8	7.3	82.8	7.3	82.8	7.3
P08	=	130	165	145	110	M 8	18	7	70	60.8	9.8	60.8	9.8	60.8	9.8	60.8	9.8	60.8	9.8	85.8	10.3	85.8	10.3	85.8	10.3	85.8	10.3
P09	=	180	230	200	114.3	13.5	22	11	70	64.8	13.8	64.8	13.8	64.8	13.8	64.8	13.8	64.8	13.8	89.8	14.3	89.8	14.3	89.8	14.3	89.8	14.3
P10	=	115	150	130	95	M 8	15	4.5	70	57.8	6.8	57.8	6.8	57.8	6.8	57.8	6.8	57.8	6.8	82.8	7.3	82.8	7.3	82.8	7.3	82.8	7.3
P11	=	180	230	198	155	13.5	22	7	120x11	64.8	13.8	64.8	13.8	64.8	13.8	64.8	13.8	64.8	13.8	89.8	14.3	89.8	14.3	89.8	14.3	89.8	14.3
P12	=	220	270	235	200	13.5	15	5	70	57.8	6.8	57.8	6.8	57.8	6.8	57.8	6.8	57.8	6.8	82.8	7.3	82.8	7.3	82.8	7.3	82.8	7.3
P13	=	190	250	215	130	13	15	4.5	70	57.8	6.8	57.8	6.8	57.8	6.8	57.8	6.8	57.8	6.8	82.8	7.3	82.8	7.3	82.8	7.3	82.8	7.3
P14	=	142	190	165	110	11	15	4.5	70	57.8	6.8	57.8	6.8	57.8	6.8	57.8	6.8	57.8	6.8	82.8	7.3	82.8	7.3	82.8	7.3	82.8	7.3
P15*	150	=	=	90	70	6.5	15	4	70	57.8	6.8	57.8	6.8	57.8	6.8	57.8	6.8	57.8	6.8	82.8	7.3	82.8	7.3	82.8	7.3	82.8	7.3
P16	=	146	200	177.8	114.3	10.5	15	3.5	70	57.8	6.8	57.8	6.8	57.8	6.8	57.8	6.8	57.8	6.8	82.8	7.3	82.8	7.3	82.8	7.3	82.8	7.3
P17	=	130	165	145	110	M 8	28	7	70	70.8	19.8	70.8	19.8	70.8	19.8	70.8	19.8	70.8	19.8	95.8	20.3	95.8	20.3	95.8	20.3	95.8	20.3
P18	140	=	=	100	80	M 6	22	6	70	64.8	13.8	64.8	13.8	64.8	13.8	64.8	13.8	64.8	13.8	89.8	14.3	89.8	14.3	89.8	14.3	89.8	14.3
P19	=	130	165	145	110	M 8	27	7	70	69.8	18.8	69.8	18.8	69.8	18.8	69.8	18.8	69.8	18.8	94.8	19.3	94.8	19.3	94.8	19.3	94.8	19.3

* Per assemblare il motore è necessario smontare la flangia dal riduttore (vedere schema di montaggio 2 a pag. 27).

* Before the mounting of the motor it is necessary to remove the flange from the gearbox (see structural arrangement 2 at the top of the page 27).

* Vor dem Einbauen des Motors soll die Getriebeflangens abmontiert werden (siehe Bauanleitung 2 auf Seite 27).

1 Schema di montaggio / Assembly drawing / Bauanleitung 1

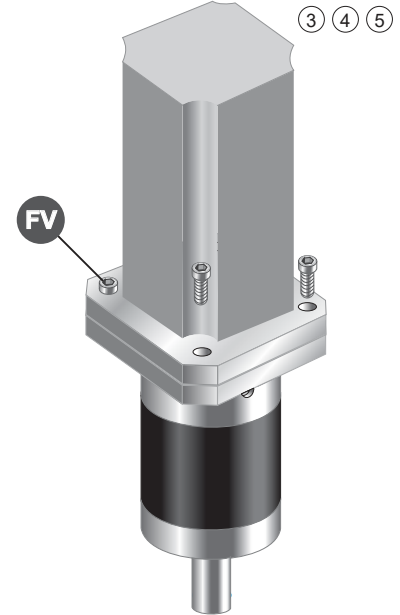
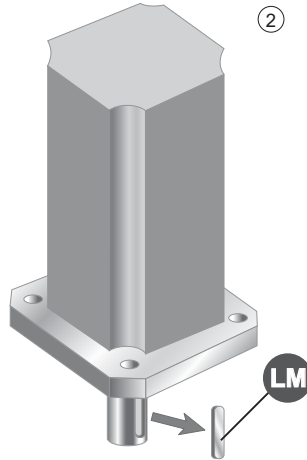
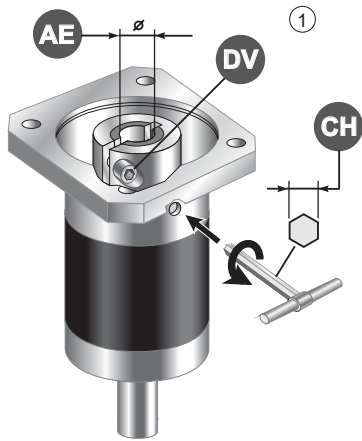

- 1 - Allentare la vite di serraggio del morsetto (DV)
- 2 - Estrarre la linguetta (LM) dall'albero motore
- 3 - Pulire le superfici di contatto delle flange motore e riduttore
- 4 - Calettare il motore sul riduttore evitando urti
- 5 - Stringere le viti di assemblaggio (FV) in modo alternato
- 6 - Assicurarsi che il morsetto venga serrato posizionandolo verso il motore e rispettando la fasatura dei tagli
- 7 - Serrare la vite (o le viti) del morsetto (DV) alla coppia (CS) indicata in tabella

- 1 - Unloose the fastening screw (or screws) of the clamp (DV)
- 2 - Remove the key (LM) from motor shaft
- 3 - Clean the contact surfaces of motor flange/gearbox flange
- 4 - Avoid impacts while fitting motor to gearbox
- 5 - Tighten the assembling screws (FV) alternately
- 6 - Fix the clamp towards the motor and tighten it in compliance with the cuts timing
- 7 - Tighten the clamp screw, or screws (DV) according to the torque (CS) reported in the table

- 1 - die Befestigungsschraube der Klammer (DV) lockern
- 2 - die Feder (LM) aus Motorwelle ziehen
- 3 - die Motorflansch / Getriebeflansch Kontaktfläche reinigen
- 4 - Motor und Getriebe ohne Stöße verkeilen
- 5 - die Befestigungsschrauben (FV) abwechselnd anziehen
- 6 - Die Klammer soll zum Motor angezogen. Dabei soll die Zuendeinstellung de Schnitte geachtet
- 7 - die Schraube (oder Schrauben) der Klammer (DV) zu dem in der Tabelle angegebenen Anzugsmoment anziehen

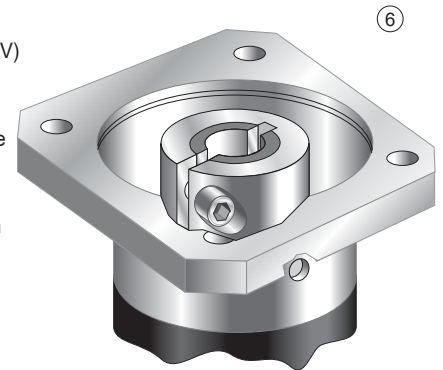

REP 075	AE	6	6.35	7	8	9	9.52	11	12	12.7	14
	DV	M4 x 16									
	NV	1									
	CH	3									
	CS [Nm]	4.8									
REP 100	AE	9	9.52	11	12	12.7	14	15.87	16	19	
	DV	M4 x 16						M5 x 20			
	NV	1						1			
	CH	3						4			
	CS [Nm]	4.8						9.4			
REP 125	AE	12.7	14	15.87	16	19	22	24	25	28	
	DV	M4 x 16		M5 x 20			M6 x 20				
	NV	1		1			2				
	CH	3		4			5				
	CS [Nm]	4.8		9.4			16.2				
REP 150	AE	15.87	16	19	22	24	28	32	35	38	
	DV	M6 x 20			M6 x 20			M6 x 20			
	NV	1			2			3			
	CH	5			5			5			
	CS [Nm]	16.2			16.2			16.2			

Tutte le viti hanno classe di resistenza 12.9
 All screws supplied according to strenght class 12.9
 Alle Schrauben nach Festigkeitsklasse 12.9 geliefert

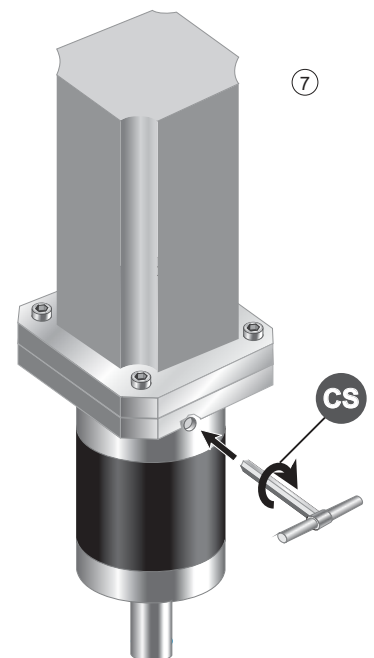

AE= Albero entrata / Input shaft / Antriebswelle
 DV= Diametro vite / Screw diameter / Schraubendurchmesser

NV= Numero viti / Number of screw / Schraubenanzahl
 CS= Coppia di serraggio / Setting torque / Spannungsmoment

2

Schema di montaggio / Assembly drawing / Bauanleitung 2

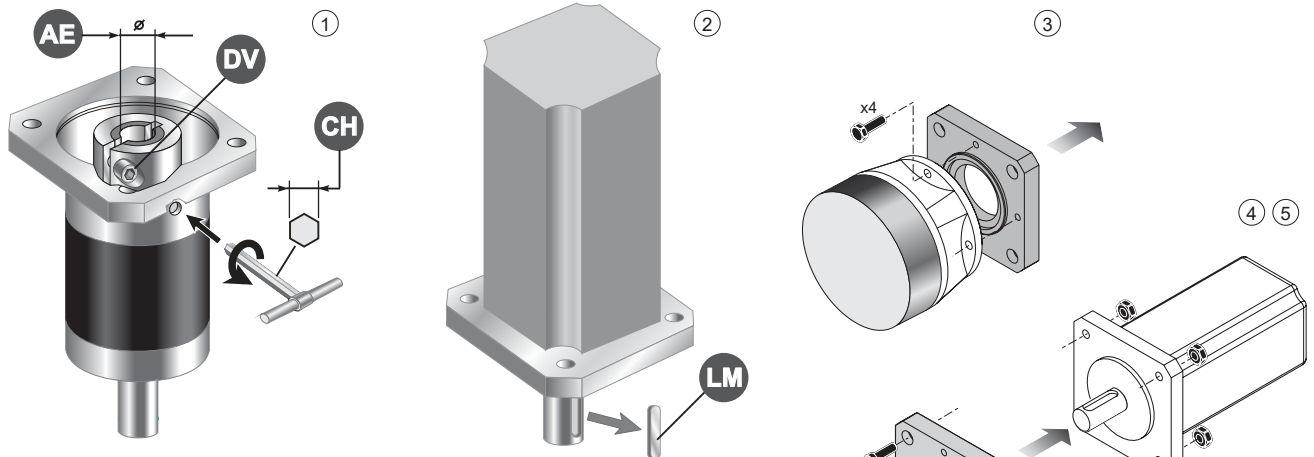

- 1 - Allentare la vite di serraggio del morsetto (DV)
- 2 - Estrarre la linguetta (LM) dall'albero motore
- 3 - Smontare la flangia dal riduttore
- 4 - Pulire le superfici di contatto delle flange motore e riduttore
- 5 - Fissare la flangia sul motore
- 6 - Calettare il motore sul riduttore evitando urti
- 7 - Stringere le viti di assemblaggio (FV) in modo alternato
- 8 - Assicurarsi che il morsetto venga serrato posizionandolo verso il motore e rispettando la fasatura dei tagli
- 9 - Serrare la vite (o le viti) del morsetto (DV) alla coppia (CS) indicata in tabella

- 1 - Unloose the fastening screw (or screws) of the clamp (DV)
- 2 - Remove the key (LM) from motor shaft
- 3 - Remove the flange from the gearbox
- 4 - Clean the contact surfaces of motor flange/gearbox flange
- 5 - Fix the flange on the motor
- 6 - Avoid impacts while fitting motor to gearbox
- 7 - Tighten the assembling screws (FV) alternatively
- 8 - Fix the clamp towards the motor and tighten it in compliance with the cuts timing
- 9 - Tighten the clamp screw, or screws (DV) according to the torque (CS) reported in the table

- 1 - die Befestigungsschraube der Klammer (DV) lockern
- 2 - die Feder (LM) aus Motorwelle ziehen
- 3 - die Flansch von Getriebe abmontieren
- 4 - die Motorflansch / Getriebe-flansch Kontaktfläche reinigen
- 5 - die Flansch an Motor befestigen
- 6 - Motor und Getriebe ohne Stöße verkeilen
- 7 - die Befestigungsschrauben (FV) abwechselnd anziehen
- 8 - Die Klammer soll zum Motor angezogen. Dabei soll die Zuendeinstellung de Schnitte geachtet
- 9 - die Schraube (oder Schrauben) der Klammer (DV) zu dem in der Tabelle angegebenen Anzugsmoment anziehen

	AE	6	6.35	7	8	9	9.52	11	12	12.7	14
REP 075	DV	M4 x 16									
	NV	1									
	CH	3									
	CS [Nm]	4.8									
	AE	9	9.52	11	12	12.7	14	15.87	16	19	
REP 100	DV	M4 x 16						M5 x 20			
	NV	1						1			
	CH	3						4			
	CS [Nm]	4.8						9.4			
	AE	12.7	14	15.87	16	19	22	24	25	28	
REP 125	DV	M4 x 16		M5 x 20			M6 x 20				
	NV	1		1			2				
	CH	3		4			5				
	CS [Nm]	4.8		9.4			16.2				
	AE	15.87	16	19	22	24	28	32	35	38	
REP 150	DV	M6 x 20			M6 x 20			M6 x 20			
	NV	1			2			3			
	CH	5			5			5			
	CS [Nm]	16.2			16.2			16.2			

Tutte le viti hanno classe di resistenza 12.9
 All screws supplied according to strenght class 12.9
 Alle Schrauben nach Festigkeitsklasse 12.9 geliefert

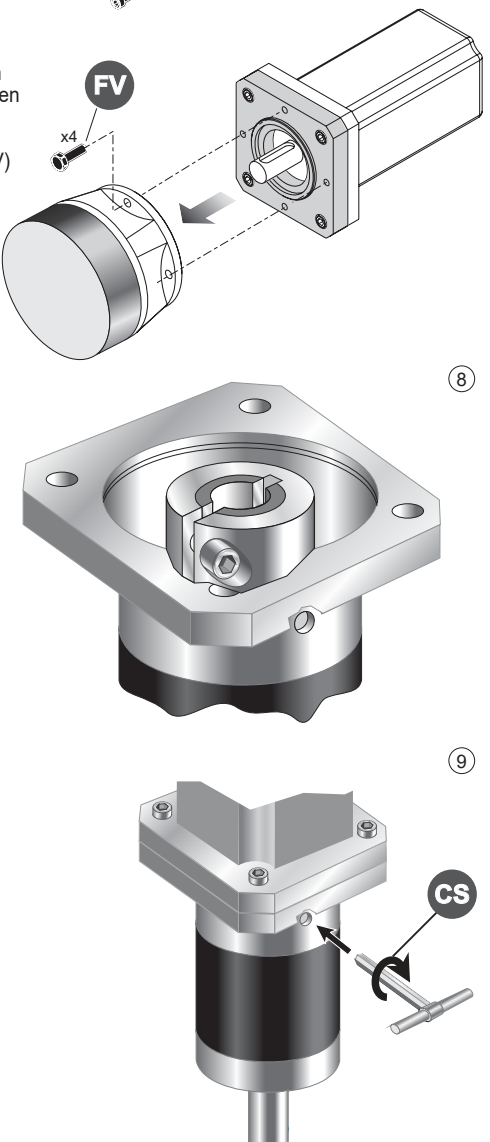

AE= Albero entrata / Input shaft / Antriebswelle
 DV= Diametro vite / Screw diameter / Schraubendurchmesser

NV= Numero viti / Number of screw / Schraubenanzahl
 CS= Coppia di serraggio / Setting torque / Spannungsmoment

2.0	RIDUTTORI EPICICLOIDALI SERIE EP	PLANETARY GEARBOXES EP SERIES	PLANETENGETRIEBE SERIE EP	
2.1	Caratteristiche	<i>Characteristics</i>	Merkmale	30
2.2	Designazione	<i>Designation</i>	Bezeichnung	31
2.3	Selezione	<i>Selection</i>	Getriebeauswahl	31
2.4	Gioco angolare	<i>Backlash</i>	Spiel	31
2.5	Carichi radiali e assiali su albero lento	<i>Radial and axial loads on output shaft</i>	Radial-und Axiallasten an der Ausgangswelle	32
2.6	Lubrificazione	<i>Lubrication</i>	Schmierung	32
2.7	Momento d'inerzia	<i>Moment of inertia</i>	Trägheitsmoment	33
2.8	Dati tecnici	<i>Technical data</i>	Technische Daten	36
2.9	Dimensioni	<i>Dimensions</i>	Abmessungen	36
2.10	Istruzioni per il montaggio del motore	<i>Instructions for the motor assem- bling</i>	Anleitung für Motoranbau	46



2.1 Caratteristiche

La serie di riduttori epicicloidali EP è il risultato di un ottimo rapporto tra economicità del prezzo e garanzia di precisione delle caratteristiche di funzionamento. I nostri riduttori sono stati realizzati per un'utilizzo prevalente sulle seguenti applicazioni:

- Macchine utensili
- Macchine per la lavorazione del legno
- Linee transfer
- Macchine da stampa
- Macchine automatiche per confezionamento ed imballaggio
- Automazioni
- Manipolatori
- Macchine serigrafiche
- Guide lineari

La gamma dei riduttori è costituita da 5 grandezze (55, 75, 90, 120 e 155), a 1 e 2 stadi di riduzione, ognuna con due tipi di alberi uscita (tipo A e tipo T) e flange uscita di tipo A, T e Q.

Corpo: costruito in acciaio, garantisce robustezza e una elevata affidabilità nel tempo.

Flange: le flange in entrata ed in uscita sono costruite in alluminio e sono disponibili in molteplici varianti costruttive.

Alberi: sono costruiti in acciaio legato bonificato.

Ingranaggi: in acciaio legato da cementazione e tempra, con dentature rettificata.

Cuscinetti: di elevata qualità opportunamente dimensionati per garantire elevate durate e silenziosità di funzionamento.

2.1 Characteristics

The planetary gearbox EP series is the result of the outstanding ratio competitive price / precision guaranteed with regard to operating features. Our gearboxes are manufactured for prevailing utilization in the following applications:

- *Machine tools*
- *Woodworking machines*
- *Transfer machines*
- *Printing machines*
- *Automatic packing and packaging machines*
- *Automation*
- *Mechanical hands*
- *Silk-screen process machines*
- *Linear guides*

The EP series is available in 5 sizes (55, 75, 90, 120 and 155), with 1 or 2 reduction stages, with two types of output shaft (A and T) and three types of output flange (A, T and Q).

Housing: made of special nitrided steel to assure strength, high reliability and long life.

Flanges: input and output flanges made of aluminium and available in several versions.

Shafts: made of hardened and tempered alloy steel.

Gears: made of casehardened and tempered alloy steel, with ground toothing.

Bearings: high quality and suitably sized to assure long life and noiseless working.

2.1 Merkmale

Die EP Serie von Planetengetrieben ist das Ergebnis des hervorragenden Verhältnis guten Preis / garantierte Präzision der Betriebseigenschaften. Unsere Getriebe sind für überwiegende Verwendung in der folgenden Applikationen hergestellt:

- Werkzeugmaschinen
- Holzbearbeitungsmaschinen
- Transfermaschinen
- Druckmaschinen
- Automatische Verpackungsmaschinen
- Automation
- Manipulatoren
- Siebdruckmaschinen
- Linearführungen

Die EP Serie ist in 5 Größen (55, 75, 90, 120 und 155) mit 1 oder 2 Untersetzungsstufen, mit zwei Typen von Abtriebswellen (A und T) und drei Typen von Abtriebsflanschen (A, T und Q) verfügbar.

Gehäuse: aus Spezial-Nitrierstahl. Garantiert Robustheit und dauerhaft hohe Zuverlässigkeit.

Ein- u. Ausgangsflansche: aus Aluminium, in zahlreichen Varianten lieferbar.

Wellen: aus vergütetem Legierungsstahl.

Zahnräder: aus Einsatzstahl mit geschliffenen Zahnflanken.

Lager: sind hochwertig und zweckmäßig bemessen, um eine lange Lebensdauer und einen geräuscharmen Lauf zu garantieren.

2.2 Designazione

2.2 Designation

2.2 Bezeichnung

Riduttore epicicloidale Planetary gearbox Planetengetriebe	Grandezza Size Größe	Numero di stadi Steps Unteretzungsstufen	Coassiale Coaxial Koaxial	Rapporto di riduzione Ratio Unteretzungsverhältnis	Albero uscita Output shaft Durchmesser Abtriebswelle	Flangia uscita Output flange Ausgangsfiansch	Albero entrata Input shaft Durchmesser Eingangswelle	Flangia in entrata Input flange Eingangsfiansch	Posizione di montaggio Mounting position Baulage
EP	55	2	C	100	A	A	AE..	P..	B5
	55 75 90 120 155	1 2	C	3 - 100	A T	A T Q	Vedi tabelle See tables Siehe Tab.	Vedi tabelle See tables Siehe Tab.	B5 V1 V3 OS

2.3 Selezione

Per la selezione dei riduttori epicicloidali EP, seguire la procedura descritta al paragrafo a pag. 6.

2.3 Selection

Make the selection of the planetary gearboxes EP Series as described at paragraph page 6.

2.3 Getriebeauswahl

Die Wahl der Planetengetriebe Serie EP wird wie im Abschnitt Seite 6.

2.4 Gioco angolare (α_{max})

Gioco massimo [arcmin] misurato sull'albero uscita, con albero entrata bloccato applicando una coppia pari al 2% della coppia nominale.

2.4 Backlash (α_{max})

Max. backlash measured on output shaft by torque equals to 2% of the nominal torque value with input shaft blocked.

2.4 Spiel (α_{max})

Maximales Spiel [arcmin], gemessen an der Abtriebswelle bei blockierter Eingangswelle mit 2% des Nennmoments.

2.5 Carichi radiali e assiali su albero lento

Nella tabella delle prestazioni sono indicati i valori, espressi in N, dei carichi assiali e radiali ammissibili alle diverse velocità per una durata dei cuscinetti di 20.000 ore. Il carico radiale F_{R2} si considera applicato ad una distanza dalla battuta pari alla metà della lunghezza dell'albero lento. Per distanze y diverse, è possibile calcolare il nuovo carico massimo ammissibile F_{R2Y} utilizzando formula e coefficienti indicati nella tabella.

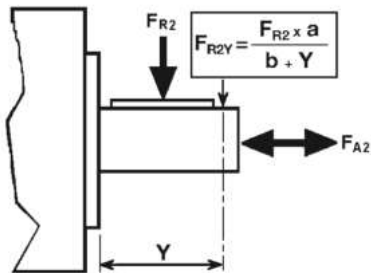

2.5 Radial and axial loads on output shaft

The table of performances shows admissible axial and radial load values expressed in N for different speeds and for a bearing life of 20.000 hours. Radial load F_{R2} calculations have been based on loads applied to the center line of the output shaft extension. For different y distance it is possible to calculate the new maximum admissible load by using formula and coefficient shown in the table.

2.5 Radial-und Axiallasten an der Abtriebswelle

Die Leistungstabelle enthält die in N ausgedrückten Werte der Axial- und Radiallasten für verschiedene Umdrehungszahlen. Diesen Werten liegt eine Lebensdauer der Lager von 20.000 Stunden zugrunde. Die Radiallast F_{R2} greift hierbei auf der Mitte der Abtriebswelle an. Greift die Radiallast an einem anderen Punkt der Abtriebswelle an, so kann man die zulässige Radiallast mit der folgenden Formel sowie den dazugehörigen Koeffizienten berechnen:

	EP 55	EP 75	EP 90	EP 120	EP 155
a	27	46	56	77	95
b	18	32	39	52	64

2.6 Lubrificazione

I riduttori EP sono forniti completi di lubrificante a vita pertanto non necessitano di manutenzione. In fase di ordine specificare la posizione di montaggio.

2.6 Lubrication

EP gearboxes are supplied filled with long-life lubricant and do not require any maintenance. When ordering it is important to specify the exact mounting position.

2.6 Schmierung

Die Planetengetriebe EP werden inklusive Dauerschmierung geliefert und sind wartungsfrei. Bei der Bestellung bitte die Einbauposition angeben.

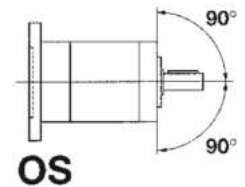
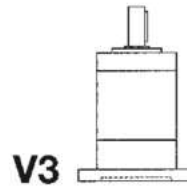
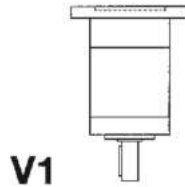
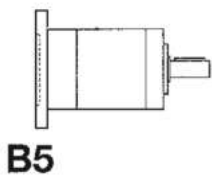

2.7 Momento d'inerzia J
[kg·cm²]

2.7 Moment of inertia J
[kg·cm²]

2.7 Trägheitsmoment J
[kg·cm²]

EP 55								
Albero entrata / Input shaft / Antriebswelle								
Stadi Steps Stufenzahl	i	6	6.35	7	8	9	9.525	11
1	3	0.07	0.07	0.07	0.09	0.09	0.09	0.09
	4	0.06	0.06	0.06	0.08	0.08	0.08	0.08
	5	0.06	0.06	0.06	0.07	0.07	0.07	0.08
	7	0.06	0.06	0.06	0.07	0.07	0.07	0.07
	10	0.05	0.05	0.05	0.07	0.07	0.07	0.07
2	9	0.07	0.07	0.07	0.09	0.09	0.09	0.09
	12	0.07	0.07	0.07	0.09	0.09	0.09	0.09
	15	0.07	0.07	0.07	0.09	0.09	0.09	0.09
	16	0.06	0.06	0.06	0.08	0.08	0.08	0.08
	20	0.06	0.06	0.06	0.08	0.08	0.07	0.08
	25	0.06	0.06	0.06	0.07	0.07	0.07	0.08
	28	0.06	0.06	0.06	0.07	0.07	0.07	0.07
	35	0.06	0.06	0.06	0.07	0.07	0.07	0.07
	40	0.05	0.05	0.05	0.07	0.07	0.07	0.07
	50	0.05	0.05	0.05	0.07	0.07	0.07	0.07
	70	0.05	0.05	0.05	0.07	0.07	0.07	0.07
	100	0.05	0.05	0.05	0.07	0.07	0.07	0.07

EP 75											
Albero entrata / Input shaft / Antriebswelle											
Stadi Steps Stufenzahl	i	6	6.35	7	8	9	9.525	11	12	12.7	14
1	3	0.17	0.17	0.17	0.18	0.18	0.18	0.20	0.20	0.20	0.22
	4	0.12	0.12	0.12	0.13	0.13	0.13	0.14	0.15	0.14	0.16
	5	0.11	0.11	0.11	0.12	0.12	0.12	0.13	0.14	0.13	0.15
	7	0.09	0.09	0.09	0.11	0.11	0.11	0.12	0.12	0.12	0.14
	10	0.09	0.09	0.09	0.10	0.10	0.10	0.11	0.12	0.11	0.13
2	9	0.16	0.16	0.16	0.17	0.17	0.17	0.19	0.19	0.19	0.21
	12	0.16	0.16	0.16	0.17	0.17	0.17	0.18	0.18	0.18	0.20
	15	0.15	0.15	0.15	0.17	0.17	0.17	0.18	0.18	0.18	0.20
	16	0.12	0.12	0.12	0.13	0.13	0.13	0.14	0.15	0.14	0.16
	20	0.12	0.12	0.12	0.13	0.13	0.13	0.14	0.14	0.14	0.16
	25	0.10	0.10	0.10	0.12	0.12	0.12	0.13	0.13	0.13	0.15
	28	0.09	0.09	0.09	0.11	0.11	0.11	0.12	0.12	0.12	0.14
	35	0.09	0.09	0.09	0.11	0.11	0.11	0.12	0.12	0.12	0.14
	40	0.09	0.09	0.09	0.10	0.10	0.10	0.11	0.12	0.11	0.13
	50	0.09	0.09	0.09	0.10	0.10	0.10	0.11	0.12	0.11	0.13
	70	0.09	0.09	0.09	0.10	0.10	0.10	0.11	0.12	0.11	0.13
	100	0.09	0.09	0.09	0.10	0.10	0.10	0.11	0.12	0.11	0.13

I valori dei momenti d'inerzia riportati si riferiscono all'albero entrata.

The moment of inertia values refer to the input shaft.

Die Werte der Trägheitsmoment beziehen sich auf die Antriebswelle.

2.7 **Momento d'inerzia J**
[kg·cm²]

2.7 **Moment of inertia J**
[kg·cm²]

2.7 **Trägheitsmoment J**
[kg·cm²]

		EP 90									
		Albero entrata / <i>Input shaft</i> / Antriebswelle									
Stadi Steps Stufenzahl	i	9	9.525	11	12	12.7	14	15.87	16	19	
1	3	0.53	0.53	0.54	0.54	0.54	0.56	0.76	0.76	0.73	
	4	0.35	0.35	0.36	0.36	0.36	0.38	0.58	0.58	0.55	
	5	0.29	0.29	0.30	0.30	0.30	0.32	0.52	0.52	0.49	
	7	0.24	0.24	0.25	0.25	0.25	0.27	0.47	0.47	0.44	
	10	0.21	0.21	0.22	0.23	0.23	0.25	0.44	0.44	0.41	
2	9	0.53	0.53	0.54	0.55	0.55	0.56	0.76	0.76	0.73	
	12	0.51	0.51	0.52	0.53	0.53	0.55	0.74	0.74	0.71	
	15	0.51	0.51	0.52	0.52	0.52	0.54	0.74	0.74	0.70	
	16	0.34	0.34	0.35	0.35	0.35	0.37	0.57	0.57	0.54	
	20	0.34	0.34	0.35	0.35	0.35	0.37	0.57	0.57	0.53	
	25	0.28	0.28	0.29	0.29	0.29	0.31	0.51	0.51	0.48	
	28	0.24	0.23	0.24	0.25	0.25	0.27	0.46	0.46	0.43	
	35	0.23	0.23	0.24	0.25	0.25	0.27	0.46	0.46	0.43	
	40	0.21	0.21	0.22	0.23	0.23	0.24	0.44	0.44	0.41	
	50	0.21	0.21	0.22	0.23	0.22	0.24	0.44	0.44	0.41	
	70	0.21	0.21	0.22	0.23	0.22	0.24	0.44	0.44	0.41	
100	0.21	0.21	0.22	0.23	0.22	0.24	0.44	0.44	0.41		

		EP 120							
		Albero entrata / <i>Input shaft</i> / Antriebswelle							
Stadi Steps Stufenzahl	i	12.7	14	15.87	16	19	22	24	28
1	3	2.02	2.08	2.25	2.25	2.22	4.36	4.32	4.17
	4	1.13	1.19	1.36	1.36	1.33	3.47	3.43	3.28
	5	0.86	0.91	1.08	1.08	1.05	3.19	3.15	3.01
	7	0.62	0.68	0.85	0.85	0.82	2.96	2.92	2.77
	10	0.51	0.56	0.73	0.73	0.70	2.84	2.80	2.66
2	9	2.00	2.06	2.23	2.23	2.20	4.34	4.30	4.15
	12	1.92	1.97	2.14	2.14	2.11	4.26	4.22	4.07
	15	1.88	1.93	2.10	2.10	2.07	4.22	4.18	4.03
	16	1.07	1.13	1.30	1.30	1.27	3.41	3.37	3.22
	20	1.05	1.10	1.28	1.28	1.24	3.39	3.35	3.20
	25	0.80	0.86	1.03	1.03	0.99	3.14	3.10	2.95
	28	0.61	0.66	0.83	0.83	0.80	2.94	2.90	2.76
	35	0.60	0.65	0.82	0.82	0.79	2.94	2.90	2.75
	40	0.50	0.55	0.72	0.72	0.69	2.83	2.79	2.65
	50	0.49	0.55	0.72	0.72	0.68	2.83	2.79	2.64
	70	0.49	0.54	0.71	0.71	0.68	2.83	2.79	2.64
100	0.49	0.54	0.71	0.71	0.68	2.83	2.79	2.64	

I valori dei momenti d'inerzia riportati si riferiscono all'albero entrata.

The moment of inertia values refer to the input shaft.

Die Werte der Trägheitsmoment beziehen sich auf die Antriebswelle.



2.7 Momento d'inerzia J
[kg·cm²]

2.7 Moment of inertia J
[kg·cm²]

2.7 Trägheitsmoment J
[kg·cm²]

EP 155										
Albero entrata / Input shaft / Antriebswelle										
Stadi Steps Stufenzahl	i	15.87	16	19	22	24	28	32	35	38
1	3	6.97	6.97	7.01	8.24	8.21	12.21	14.05	13.92	13.59
	4	4.45	4.45	4.48	5.72	5.68	9.69	11.53	11.40	11.07
	5	3.57	3.57	3.60	4.84	4.80	8.80	10.64	10.51	10.19
	7	2.86	2.86	2.89	4.13	4.09	8.09	9.93	9.81	9.48
	10	2.49	2.49	2.52	3.76	3.72	7.73	9.57	9.44	9.11
2	9	6.84	6.84	6.87	8.11	8.07	12.07	13.91	13.79	13.46
	12	6.55	6.55	6.59	7.83	7.79	11.79	13.63	13.51	13.18
	15	6.46	6.46	6.49	7.73	7.69	11.70	13.54	13.41	13.08
	16	4.22	4.22	4.25	5.49	5.45	9.45	11.29	11.17	10.84
	20	4.16	4.16	4.19	5.43	5.40	9.40	11.24	11.11	10.78
	25	3.38	3.38	3.41	4.65	4.62	8.62	10.46	10.33	10.00
	28	2.78	2.78	2.81	4.05	4.02	8.02	9.86	9.73	9.40
	35	2.76	2.76	2.80	4.03	4.00	8.00	9.84	9.71	9.38
	40	2.45	2.45	2.48	3.72	3.69	7.69	9.53	9.40	9.07
	50	2.44	2.44	2.48	3.71	3.68	7.68	9.52	9.39	9.06
	70	2.44	2.44	2.47	3.71	3.67	7.67	9.51	9.39	9.06
100	2.43	2.43	2.46	3.70	3.67	7.67	9.51	9.38	9.05	

I valori dei momenti d'inerzia riportati si riferiscono all'albero entrata.

The moment of inertia values refer to the input shaft.

Die Werte der Trägheitsmoment beziehen sich auf die Antriebswelle.

EP 55																		Stadi Steps Stufenzahl	
Stadi Steps Stufenzahl	1					2												1	2
	i	3	4	5	7	10	9	12	15	16	20	25	28	35	40	50	70		
T _{2N}	12	14	16	12	10	14	16	16	16	16	16	16	16	16	16	14	12	n _{1nom}	4000
T _{2A}	22	24	24	22	20	24	28	28	28	28	28	28	28	28	28	24	22	n _{1max}	5000
T _{2S}	44	48	48	44	40	48	56	56	56	56	56	56	56	56	56	48	44	LpA	< 70
J	Vedi pag. 31 / See page 31 / Siehe auf Seite 31																	Lh	20000
R _t	1.0					0.9					1.0					0.9		F _{R2}	300
R _d	0.96					0.93												F _{A2}	450
Kg	0.8					1.8												α _{max}	8' 10'

F_{R2} Carico radiale nominale in uscita [N] a 100min⁻¹
 F_{A2} Carico assiale in uscita [N] a 100min⁻¹

Rated output radial load [N] at 100min⁻¹
 Output axial load [N] at 100min⁻¹

Nenn-Radiallast an der Abtriebswelle bei 100min⁻¹
 Axiallast an der Abtriebswelle bei 100min⁻¹

2.9 Dimensioni

2.9 Dimensions

2.9 Abmessungen

Dimensioni generali e uscite / General and output dimensions / General-und Abtriebsabmessungen

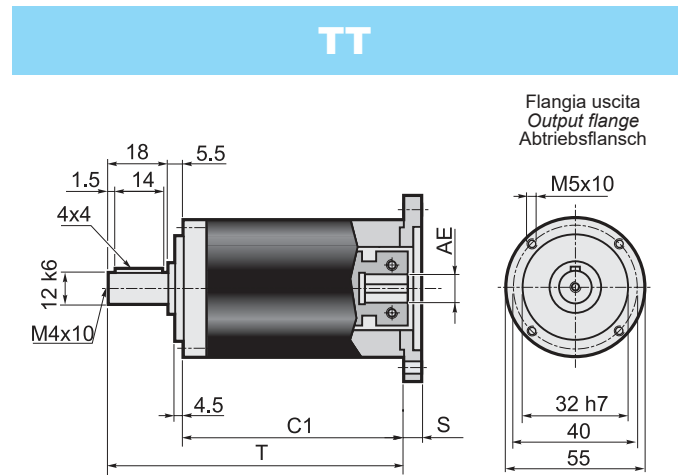
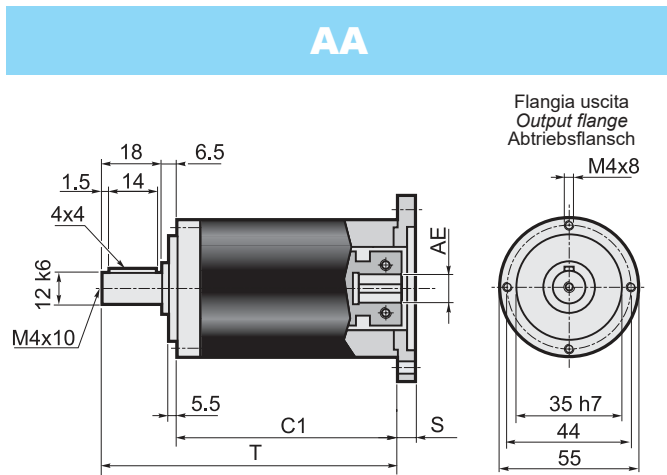

Stadi / Steps / Stufenzahl	1	2	AE=
C1	62.5	81.5	6 - 6.35 - 7 - 8 - 9 - 9.52 - 11
T	87	106	

Stadi / Steps / Stufenzahl	1	2	AE=
C1	63.5	82.5	6 - 6.35 - 7 - 8 - 9 - 9.52 - 11
T	87	106	

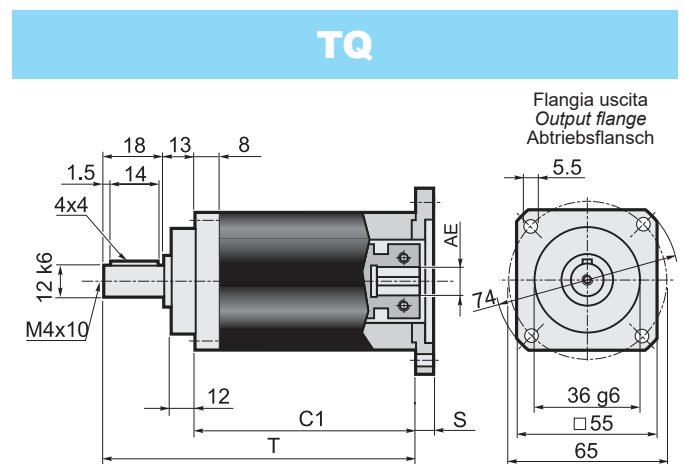
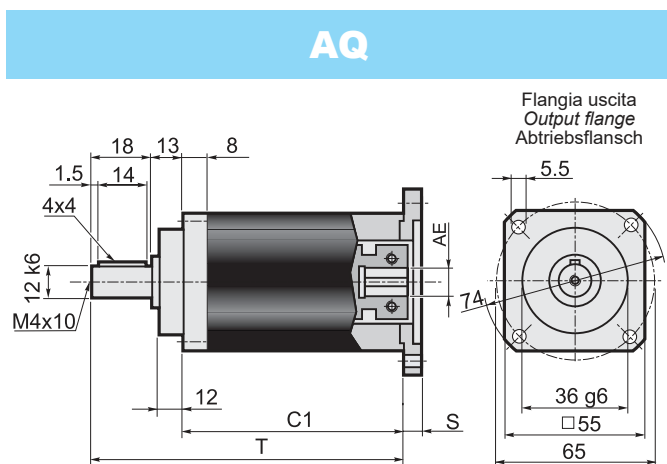

Stadi / Steps / Stufenzahl	1	2	AE=
C1	56	75	6 - 6.35 - 7 - 8 - 9 - 9.52 - 11
T	87	106	

Stadi / Steps / Stufenzahl	1	2	AE=
C1	56	75	6 - 6.35 - 7 - 8 - 9 - 9.52 - 11
T	87	106	

Dimensioni entrate / Input dimensions / Antriebsabmessungen

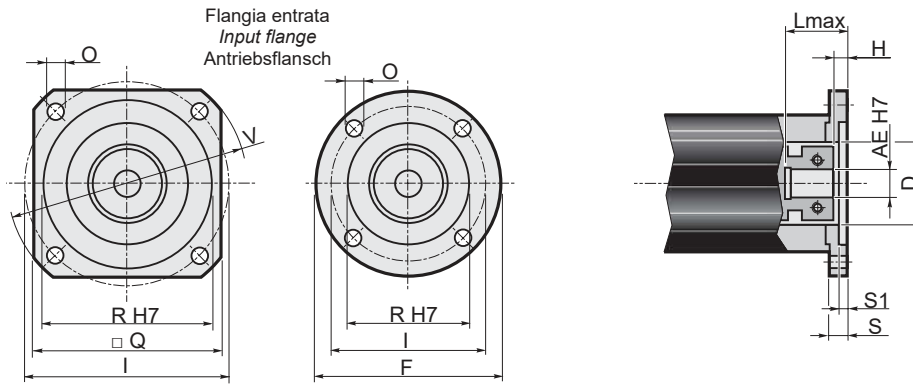

	Flange entrata / Input flange / Antriebsflansch									Albero entrata / Input shaft / Antriebswelle													
										AE													
	F	Q	V	I	R (H7)	O	S	S1	D	6		6.35		7		8		9		9.52		11	
									L _{max}	H	L _{max}	H	L _{max}	H	L _{max}	H	L _{max}	H	L _{max}	H	L _{max}	H	
P01*	60	=	=	43.82	22	4.5	10	3	22	30	7	30	7	30	7	30	7	30	7	30	7	30	7
P02*	=	60	80	66.67	38.1	5.5	10	3	32	30	7	30	7	30	7	30	7	30	7	30	7	30	7
P03*	=	60	80	63	40	5.5	10	3.5	32	30	7	30	7	30	7	30	7	30	7	30	7	30	7
P04	=	70	90	75	60	6.5	10.5	3.5	32	30.5	7.5	30.5	7.5	30.5	7.5	30.5	7.5	30.5	7.5	30.5	7.5	30.5	7.5
P05	105	=	=	85	70	6.5	10.5	3.5	32	30.5	7.5	30.5	7.5	30.5	7.5	30.5	7.5	30.5	7.5	30.5	7.5	30.5	7.5
P06	=	80	110	98.42	73.02	6	11	3.5	35	31	8	31	8	31	8	31	8	31	8	31	8	31	8
P07	=	95	120	100	80	6.5	11.5	4	32	31.5	8.5	31.5	8.5	31.5	8.5	31.5	8.5	31.5	8.5	31.5	8.5	31.5	8.5
P08	=	98	130	115	95	9	11.5	4	32	31.5	8.5	31.5	8.5	31.5	8.5	31.5	8.5	31.5	8.5	31.5	8.5	31.5	8.5
P09	=	116	160	130	110	9	12	4.5	32	32	9	32	9	32	9	32	9	32	9	32	9	32	9
P10*	60	=	=	39	26	4.5	10	3	26	30	7	30	7	30	7	30	7	30	7	30	7	30	7
P11*	60	=	=	42	32	4.5	10	3	32	30	7	30	7	30	7	30	7	30	7	30	7	30	7
P12*	65	=	=	46	32	4.5	10	3.5	32	30	7	30	7	30	7	30	7	30	7	30	7	30	7
P13*	80	=	=	65	50	5.5	10	3.5	32	30	7	30	7	30	7	30	7	30	7	30	7	30	7
P14*	60	=	=	39	20	4.5	10	2.5	20	30	7	30	7	30	7	30	7	30	7	30	7	30	7
P15	=	75	100	90	60	5.8	12	3.5	32	32	9	32	9	32	9	32	9	32	9	32	9	32	9
P16*	60	=	=	45	30	3.5	14	7	30	34	11	34	11	34	11	34	11	34	11	34	11	34	11
P17	=	60	82	70	50	4.5	16.5	8	32	36.5	13.5	36.5	13.5	36.5	13.5	36.5	13.5	36.5	13.5	36.5	13.5	36.5	13.5
P18	=	60	80	60	50	M4	10.5	3.5	32	30.5	7.5	30.5	7.5	30.5	7.5	30.5	7.5	30.5	7.5	30.5	7.5	30.5	7.5
P19*	60	=	=	36	25	4.5	10	3	25	30	7	30	7	30	7	30	7	30	7	30	7	30	7
P20	=	60	82	70	50	5.5	10.5	3.5	32	30.5	7.5	30.5	7.5	30.5	7.5	30.5	7.5	30.5	7.5	30.5	7.5	30.5	7.5
P21*	60	=	=	46	30	4.5	10	3	30	30	7	30	7	30	7	30	7	30	7	30	7	30	7
P22	=	60	80	70.71	36	4.5	10	2	32	30	7	30	7	30	7	30	7	30	7	30	7	30	7
P23	=	62	85	70	50	5.5	15.5	3.5	32	35.5	12.5	35.5	12.5	35.5	12.5	35.5	12.5	35.5	12.5	35.5	12.5	35.5	12.5
P24	=	75	100	90	70	5.8	12	3.5	32	32	9	32	9	32	9	32	9	32	9	32	9	32	9
P25	=	70	95	85	55	5.8	12	3.5	32	32	9	32	9	32	9	32	9	32	9	32	9	32	9
P26*	=	60	80	65.5	34	5.5	10	3.5	33	30	7	30	7	30	7	30	7	30	7	30	7	30	7
P27	=	80	110	95	50	6.5	12	3.5	32	32	9	32	9	32	9	32	9	32	9	32	9	32	9
P28	=	60	80	66.67	38.1	M4	9	2.5	32	29	6	29	6	29	6	29	6	29	6	29	6	29	6
P29	60	=	=	45	30	M3	11	4	32	31	8	31	8	31	8	31	8	31	8	31	8	31	8
P30	=	70	95	85	60	5.8	12	3.5	32	32	9	32	9	32	9	32	9	32	9	32	9	32	9
P31	=	62	85	70	50	M4	11	3.5	32	31	8	31	8	31	8	31	8	31	8	31	8	31	8
P32	=	60	80	65	40	M5	10	3.5	32	30	7	30	7	30	7	30	7	30	7	30	7	30	7
P33	=	85	115	99	60	5.5	11	3.5	35	31	8	31	8	31	8	31	8	31	8	31	8	31	8
P34	=	65	87	73.54	40	M4	10	3.5	32	30	7	30	7	30	7	30	7	30	7	30	7	30	7
P35	=	60	80	70.71	36	M4	14	2	32	34	11	34	11	34	11	34	11	34	11	34	11	34	11
P36	=	85	115	98.42	73.02	6	15	3.5	35	35	12	35	12	35	12	35	12	35	12	35	12	35	12
P37	=	95	120	100	80	6.5	16.5	5	32														
P38	60	=	=	48	30	M3	11	7	32	31	8	31	8	31	8	31	8	31	8	31	8	31	8
P41*	68	=	=	50	30	5.5	10	10	30	30	7	30	7	30	7	30	7	30	7	30	7	30	7
P43	=	60	80	66.67	50	M5	9	2.5	32	29	6	29	6	29	6	29	6	29	6	29	6	29	6
P44*	60	=	=	32	25	4.5	9	2.5	20	29	6	29	6	29	6	29	6	29	6	29	6	29	6
P45	=	62	85	73.54	50	M5	10	3	32	30	7	30	7	30	7	30	7	30	7	30	7	30	7
P46	70	=	=	55	45	4.5	9	3	32	29	6	29	6	29	6	29	6	29	6	29	6	29	6
P47	=	90	118	104	83	6.5	14	3.5	32	34	11	34	11	34	11	34	11	34	11	34	11	34	11
P48*	60	=	=	38.88	25	4.5	10	3	25	30	7	30	7	30	7	30	7	30	7	30	7	30	7
P49	=	70	90	75	60	M5	10.5	3.5	32	30.5	7.5	30.5	7.5	30.5	7.5	30.5	7.5	30.5	7.5	30.5	7.5	30.5	7.5

* Per assemblare il motore è necessario smontare la flangia dal riduttore (vedere schema di montaggio 2 a pag. 47).

* Before the mounting of the motor it is necessary to remove the flange from the gearbox (see structural arrangement 2 at the top of the page 47).

* Vor dem Einbauen des Motors soll die Getriebeflang abmontiert werden (siehe Bauanleitung 2 auf Seite 47).

EP 75																		Stadi Steps Stufenzahl			
Stadi Steps Stufenzahl	1					2												1	2		
	i	3	4	5	7	10	9	12	15	16	20	25	28	35	40	50	70			100	
T _{2N}	22	28	32	28	20	26	32	36	36	36	36	36	36	36	36	30	22	n _{1nom}	4000		
T _{2A}	40	45	50	45	40	50	60	60	60	60	60	60	60	60	60	50	45	n _{1max}	5000		
T _{2S}	80	90	100	90	80	100	120	120	120	120	120	120	120	120	120	100	90	LpA	< 70		
J	Vedi pag. 31 / See page 31 / Siehe auf Seite 31																	Lh	20000		
R _t	3.5					3.0		3.5										3.0		F _{R2}	1800
R _d	0.96					0.93												F _{A2}	1400		
Kg	1.4					2.0												α _{max}	8' 10'		

F_{R2} Carico radiale nominale in uscita [N] a 100min⁻¹
 F_{A2} Carico assiale in uscita [N] a 100min⁻¹

Rated output radial load [N] at 100min⁻¹
 Output axial load [N] at 100min⁻¹

Nenn-Radiallast an der Abtriebswelle bei 100min⁻¹
 Axiallast an der Abtriebswelle bei 100min⁻¹

2.9 Dimensioni

2.9 Dimensions

2.9 Abmessungen

Dimensioni generali e uscite / General and output dimensions / General-und Abtriebsabmessungen

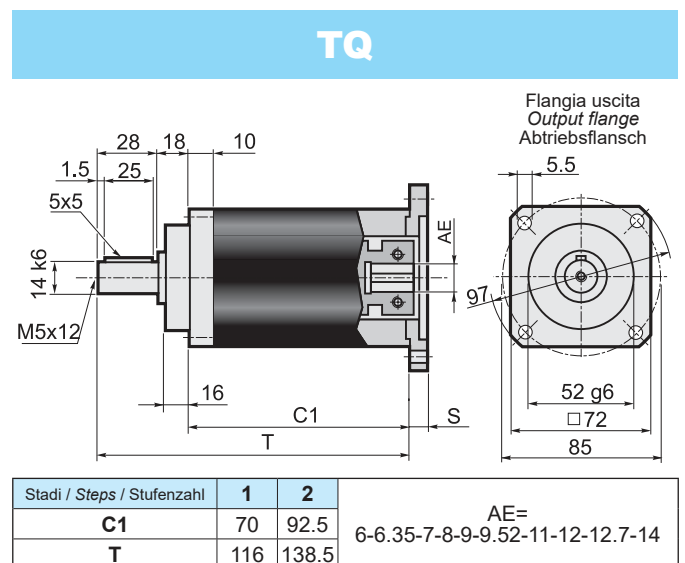
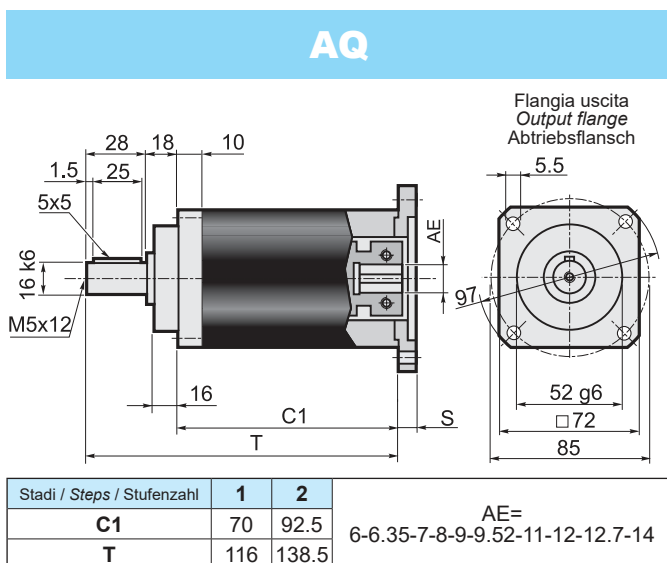
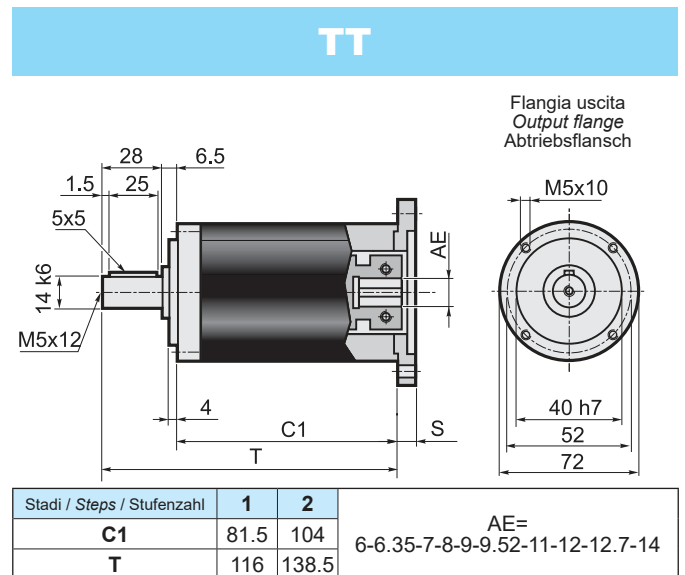
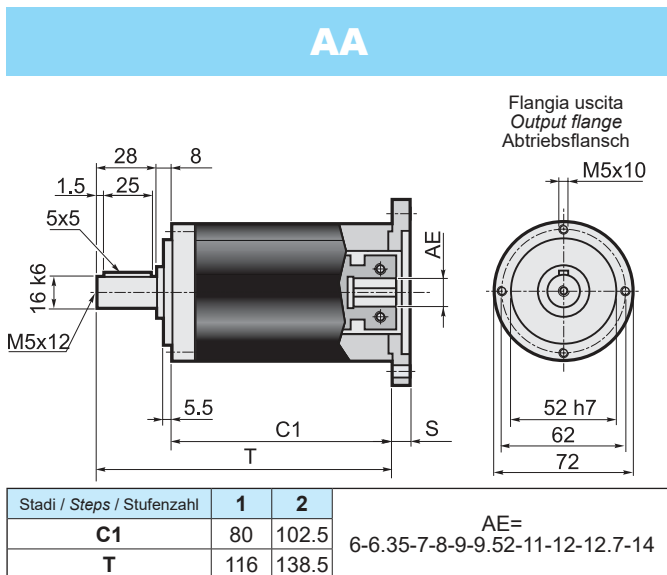

Dimensioni entrate / Input dimensions / Antriebsabmessungen

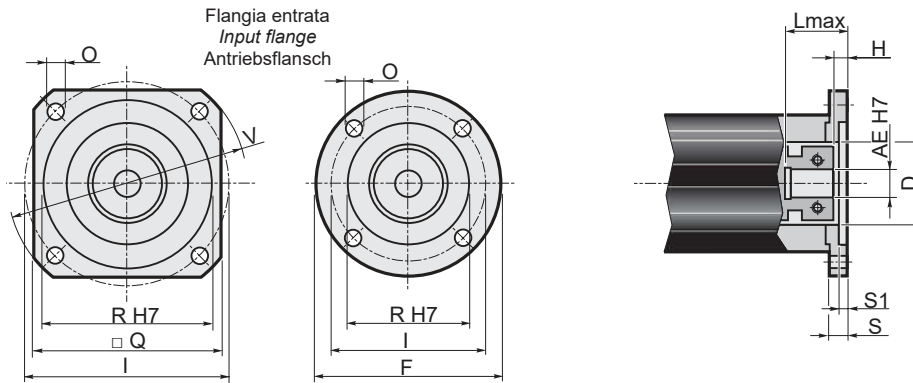

Flange entrata / Input flange / Antriebsflansch										Albero entrata / Input shaft / Antriebswelle																	
										AE																	
										6		6.35		7		8		9		9.52		11		12		12.7	
F	Q	V	I	R (H7)	O	S	S1	D	L _{max}	H	L _{max}	H	L _{max}	H	L _{max}	H	L _{max}	H	L _{max}	H	L _{max}	H	L _{max}	H	L _{max}	H	
P01*	60	=	=	43.82	22	4.5	10	3	22	35	4.5	35	4.5	35	4.5	26	6.5	26	6.5	35	6.5	26	6.5	35	6.5	35	6.5
P02*	=	60	80	66.67	38.1	5.5	10	3	32	35	4.5	35	4.5	35	4.5	26	6.5	26	6.5	35	6.5	26	6.5	35	6.5	35	6.5
P03*	=	60	80	63	40	5.5	10	3.5	32	35	4.5	35	4.5	35	4.5	26	6.5	26	6.5	35	6.5	26	6.5	35	6.5	35	6.5
P04	=	70	90	75	60	6.5	10.5	3.5	32	35.5	5	35.5	5	35.5	5	26.5	7	26.5	7	35.5	7	26.5	7	35.5	7	35.5	7
P05	105	=	=	85	70	6.5	10.5	3.5	32	35.5	5	35.5	5	35.5	5	26.5	7	26.5	7	35.5	7	26.5	7	35.5	7	35.5	7
P06	=	80	110	98.42	73.02	6	11	3.5	35	36	5.5	36	5.5	36	5.5	27	7.5	27	7.5	36	7.5	27	7.5	36	7.5	36	7.5
P07	=	95	120	100	80	6.5	11.5	4	32	36.5	6	36.5	6	36.5	6	27.5	8	27.5	8	36.5	8	27.5	8	36.5	8	36.5	8
P08	=	98	130	115	95	9	11.5	4	32	36.5	6	36.5	6	36.5	6	27.5	8	27.5	8	36.5	8	27.5	8	36.5	8	36.5	8
P09	=	116	160	130	110	9	12	4.5	32	37	6.5	37	6.5	37	6.5	28	8.5	28	8.5	37	8.5	28	8.5	37	8.5	37	8.5
P10*	60	=	=	39	26	4.5	10	3	26	35	4.5	35	4.5	35	4.5	26	6.5	26	6.5	35	6.5	26	6.5	35	6.5	35	6.5
P11*	60	=	=	42	32	4.5	10	3	32	35	4.5	35	4.5	35	4.5	26	6.5	26	6.5	35	6.5	26	6.5	35	6.5	35	6.5
P12*	65	=	=	46	32	4.5	10	3.5	32	35	4.5	35	4.5	35	4.5	26	6.5	26	6.5	35	6.5	26	6.5	35	6.5	35	6.5
P13*	80	=	=	65	50	5.5	10	3.5	32	35	4.5	35	4.5	35	4.5	26	6.5	26	6.5	35	6.5	26	6.5	35	6.5	35	6.5
P14*	60	=	=	39	20	4.5	10	2.5	20	35	4.5	35	4.5	35	4.5	26	6.5	26	6.5	35	6.5	26	6.5	35	6.5	35	6.5
P15	=	75	100	90	60	5.8	12	3.5	32	37	6.5	37	6.5	37	6.5	28	8.5	28	8.5	37	8.5	28	8.5	37	8.5	37	8.5
P16*	60	=	=	45	30	3.5	14	7	30	39	8.5	39	8.5	39	8.5	30	10.5	30	10.5	39	10.5	30	10.5	39	10.5	39	10.5
P17	=	60	82	70	50	4.5	16.5	8	32	41.5	11	41.5	11	41.5	11	32.5	13	32.5	13	41.5	13	32.5	13	41.5	13	41.5	13
P18	=	60	80	60	50	M4	10.5	3.5	32	35.5	5	35.5	5	35.5	5	26.5	7	26.5	7	35.5	7	26.5	7	35.5	7	35.5	7
P19*	60	=	=	36	25	4.5	10	3	25	35	4.5	35	4.5	35	4.5	26	6.5	26	6.5	35	6.5	26	6.5	35	6.5	35	6.5
P20	=	60	82	70	50	5.5	10.5	3.5	32	35.5	5	35.5	5	35.5	5	26.5	7	26.5	7	35.5	7	26.5	7	35.5	7	35.5	7
P21*	60	=	=	46	30	4.5	10	3	30	35	4.5	35	4.5	35	4.5	26	6.5	26	6.5	35	6.5	26	6.5	35	6.5	35	6.5
P22	=	60	80	70.71	36	4.5	10	2	32	35	4.5	35	4.5	35	4.5	26	6.5	26	6.5	35	6.5	26	6.5	35	6.5	35	6.5
P23	=	62	85	70	50	5.5	15.5	3.5	32	40.5	10	40.5	10	40.5	10	31.5	12	31.5	12	40.5	12	31.5	12	40.5	12	40.5	12
P24	=	75	100	90	70	5.8	12	3.5	32	37	6.5	37	6.5	37	6.5	28	8.5	28	8.5	37	8.5	28	8.5	37	8.5	37	8.5
P25	=	70	95	85	55	5.8	12	3.5	32	37	6.5	37	6.5	37	6.5	28	8.5	28	8.5	37	8.5	28	8.5	37	8.5	37	8.5
P26*	=	60	80	65.5	34	5.5	10	3.5	33	35	4.5	35	4.5	35	4.5	26	6.5	26	6.5	35	6.5	26	6.5	35	6.5	35	6.5
P27	=	80	110	95	50	6.5	12	3.5	32	37	6.5	37	6.5	37	6.5	28	8.5	28	8.5	37	8.5	28	8.5	37	8.5	37	8.5
P28	=	60	80	66.67	38.1	M4	9	2.5	32	34	3.5	34	3.5	34	3.5	25	5.5	25	5.5	34	5.5	25	5.5	34	5.5	34	5.5
P29	60	=	=	45	30	M3	11	4	32	36	5.5	36	5.5	36	5.5	27	7.5	27	7.5	36	7.5	27	7.5	36	7.5	36	7.5
P30	=	70	95	85	60	5.8	12	3.5	32	37	6.5	37	6.5	37	6.5	28	8.5	28	8.5	37	8.5	28	8.5	37	8.5	37	8.5
P31	=	62	85	70	50	M4	11	3.5	32	36	5.5	36	5.5	36	5.5	27	7.5	27	7.5	36	7.5	27	7.5	36	7.5	36	7.5
P32	=	60	80	65	40	M5	10	3.5	32	35	4.5	35	4.5	35	4.5	26	6.5	26	6.5	35	6.5	26	6.5	35	6.5	35	6.5
P33	=	85	115	99	60	5.5	11	3.5	32	36	5.5	36	5.5	36	5.5	27	7.5	27	7.5	36	7.5	27	7.5	36	7.5	36	7.5
P34	=	65	87	73.54	40	M4	10	3.5	32	35	4.5	35	4.5	35	4.5	26	6.5	26	6.5	35	6.5	26	6.5	35	6.5	35	6.5
P35	=	60	80	70.71	36	M4	14	2	32	39	8.5	39	8.5	39	8.5	30	10.5	30	10.5	39	10.5	30	10.5	39	10.5	39	10.5
P36	=	85	115	98.42	73.02	6	15	3.5	35	40	9.5	40	9.5	40	9.5	35	11.5	35	11.5	40	11.5	35	11.5	40	11.5	40	11.5
P37	=	95	120	100	80	6.5	16.5	5	32	41.5	11	41.5	11	41.5	11	32.5	13	32.5	13	41.5	13	32.5	13	41.5	13	41.5	13
P38	60	=	=	48	30	M3	11	7	32	36	5.5	36	5.5	36	5.5	27	7.5	27	7.5	36	7.5	27	7.5	36	7.5	36	7.5
P41*	68	=	=	50	30	5.5	10	10	30	35	4.5	35	4.5	35	4.5	26	6.5	26	6.5	35	6.5	26	6.5	35	6.5	35	6.5
P43	=	60	80	66.67	50	M5	9	2.5	32	34	3.5	34	3.5	34	3.5	25	5.5	25	5.5	34	5.5	25	5.5	34	5.5	34	5.5
P44*	60	=	=	32	25	4.5	9	2.5	20	34	3.5	34	3.5	34	3.5	25	5.5	25	5.5	34	5.5	25	5.5	34	5.5	34	5.5
P45	=	62	85	73.54	50	M5	10	3	32	35	4.5	35	4.5	35	4.5	26	6.5	26	6.5	35	6.5	26	6.5	35	6.5	35	6.5
P46	70	=	=	55	45	4.5	9	3	32	34	3.5	34	3.5	34	3.5	25	5.5	25	5.5	34	5.5	25	5.5	34	5.5	34	5.5
P47	=	90	118	104	83	6.5	14	3.5	32	39	8.5	39	8.5	39	8.5	30	10.5	30	10.5	39	10.5	30	10.5	39	10.5	39	10.5
P48	60	=	=	38.88	25	4.5	10	3	25	35	4.5	35	4.5	35	4.5	26	6.5	26	6.5	35	6.5	26	6.5	35	6.5	35	6.5
P49	=	70	90	75	60	M5	10.5	3.5	32	35.5	5	35.5	5	35.5	5	26.5	7	26.5	7	35.5	7	26.5	7	35.5	7	35.5	7

* Per assemblare il motore è necessario smontare la flangia dal riduttore (vedere schema di montaggio 2 a pag. 47).

* Before the mounting of the motor it is necessary to remove the flange from the gearbox (see structural arrangement 2 at the top of the page 47).

* Vor dem Einbauen des Motors soll die Getriebeflang abmontiert werden (siehe Bauanleitung 2 auf Seite 47).

2.8 Dati tecnici

2.8 Technical data

2.8 Technische Daten

EP 90																		Stadi Steps Stufenzahl		
Stadi Steps Stufenzahl	1					2												1	2	
	i	3	4	5	7	10	9	12	15	16	20	25	28	35	40	50	70			100
T_{2N}	50	55	60	55	50	65	70	75	75	75	75	75	75	75	75	65	55	n_{1nom}	4000	
T_{2A}	80	90	100	90	80	100	110	120	120	120	120	120	120	120	120	100	90	n_{1max}	5000	
T_{2S}	160	180	200	180	160	200	220	240	240	240	240	240	240	240	240	200	180	LpA	< 70	
J	Vedi pag. 32 / See page 32 / Siehe auf Seite 32																	Lh	20000	
R_t	9.0					7.5					9.0					7.5			F_{R2}	2600
R_d	0.96					0.93												F_{A2}	2000	
Kg	2.8					3.7												α_{max}	8' 10'	

F_{R2} Carico radiale nominale in uscita [N] a 100min⁻¹
F_{A2} Carico assiale in uscita [N] a 100min⁻¹

Rated output radial load [N] at 100min⁻¹
 Output axial load [N] at 100min⁻¹

Nenn-Radiallast an der Abtriebswelle bei 100min⁻¹
 Axiallast an der Abtriebswelle bei 100min⁻¹

2.9 Dimensioni

2.9 Dimensions

2.9 Abmessungen

Dimensioni generali e uscite / General and output dimensions / General-und Abtriebsabmessungen

AA

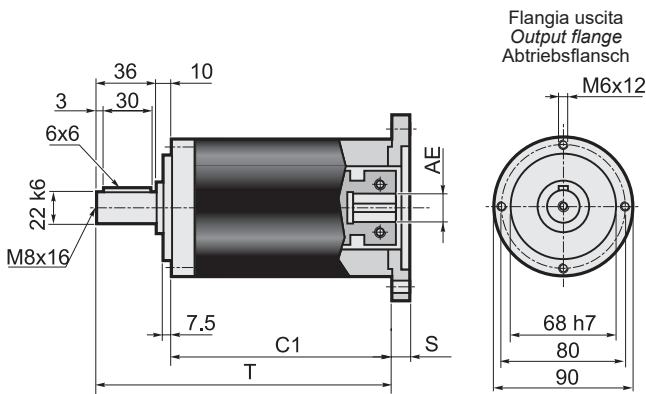

Stadi / Steps / Stufenzahl	1	2	AE= 9-9.52-11-12-12.7-14-15.87-16-19
C1	98	127	
T	144	173	

TT

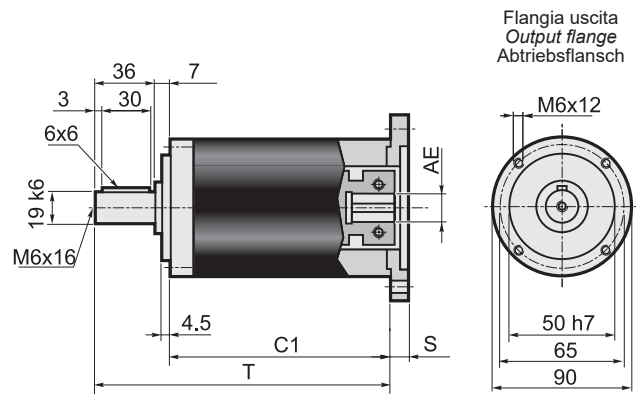

Stadi / Steps / Stufenzahl	1	2	AE= 9-9.52-11-12-12.7-14-15.87-16-19
C1	101	130	
T	144	173	

AQ

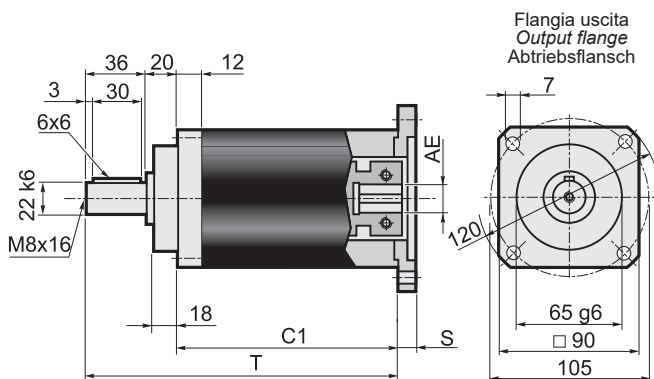

Stadi / Steps / Stufenzahl	1	2	AE= 9-9.52-11-12-12.7-14-15.87-16-19
C1	88	117	
T	144	173	

TQ

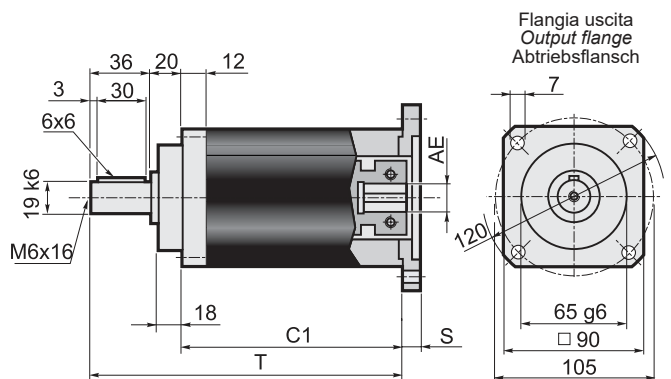

Stadi / Steps / Stufenzahl	1	2	AE= 9-9.52-11-12-12.7-14-15.87-16-19
C1	88	117	
T	144	173	

Dimensioni entrate / Input dimensions / Antriebsabmessungen

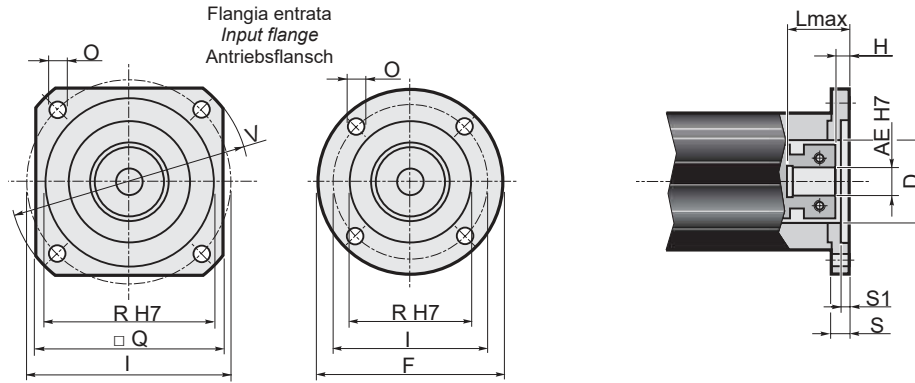

Flange entrata / Input flange / Antriebsflansch										Albero entrata / Input shaft / Antriebswelle															
										AE															
										9		9.525		11		12		12.7		14		15.87		16	
F	Q	V	I	R (H7)	O	S	S1	D	L _{max}	H	L _{max}	H	L _{max}	H	L _{max}	H	L _{max}	H	L _{max}	H	L _{max}	H	L _{max}	H	
P01*	80	=	=	66.67	38.1	5.5	12	3	38.1	44	6.5	44	9	44	9	44	9	44	9	44	9	44	9	44	9
P02	=	106.5	140	125.72	55.52	7	11	3	45	43	5.5	43	8	43	8	43	8	43	8	43	8	43	8	43	8
P03*	=	80	90	75	60	5.5	12	3.5	45	44	6.5	44	9	44	9	44	9	44	9	44	9	44	9	44	9
P04*	105	=	=	85	70	6.5	12	3.5	45	44	6.5	44	9	44	9	44	9	44	9	44	9	44	9	44	9
P05	=	82.5	110	98.425	73.02	6.5	12	3	45	44	6.5	44	9	44	9	44	9	44	9	44	9	44	9	44	9
P06	=	90	120	100	80	6.5	13	4	45	45	7.5	45	10	45	10	45	10	45	10	45	10	45	10	45	10
P07	=	100	135	115	95	8.5	13	4.5	45	45	7.5	45	10	45	10	45	10	45	10	45	10	45	10	45	10
P08	=	116	160	130	110	9	13	4.5	45	45	7.5	45	10	45	10	45	10	45	10	45	10	45	10	45	10
P09*	80	=	=	39	26	4.5	12	4	26	44	6.5	44	9	44	9	44	9	44	9	44	9	44	9	44	9
P10*	80	=	=	65	50	5.5	12	3.5	45	44	6.5	44	9	44	9	44	9	44	9	44	9	44	9	44	9
P11	=	150	182	166	115	9	32	11	50x14	64	26.5	64	29	64	29	64	29	64	29	64	29	64	29	64	29
P12*	=	80	105	90	70	6.5	12	3.5	32	44	6.5	44	9	44	9	44	9	44	9	44	9	44	9	44	9
P14*	105	=	=	90	70	6	19	9	32	51	13.5	51	16	51	16	51	16	51	16	51	16	51	16	51	16
P15*	80	=	=	70	50	4.5	17	8	45	49	11.5	49	14	49	14	49	14	49	14	49	14	49	14	49	14
P16	=	142	190	165	130	11	13	4.5	45	45	7.5	45	10	45	10	45	10	45	10	45	10	45	10	45	10
P17*	80	=	=	63	40	5.5	12	3.5	40	44	6.5	44	9	44	9	44	9	44	9	44	9	44	9	44	9
P18	=	130	170	145	110	M8	31	7	32	63	25.5	63	28	63	28	63	28	63	28	63	28	63	28	63	28
P19*	=	80	105	90	60	6.5	12	3.5	32	44	6.5	44	9	44	9	44	9	44	9	44	9	44	9	44	9
P20*	=	80	105	85	55	5.5	12	3.5	36	44	6.5	44	9	44	9	44	9	44	9	44	9	44	9	44	9
P21	=	80	110	95	50	M6	12	3.5	45	44	6.5	44	9	44	9	44	9	44	9	44	9	44	9	44	9
P22	80	=	=	70	50	M4	12	4	45	44	6.5	44	9	44	9	44	9	44	9	44	9	44	9	44	9
P23	=	80	90	75	60	M5	12	3.5	45	44	6.5	44	9	44	9	44	9	44	9	44	9	44	9	44	9
P24	80	=	=	46	30	M4	12	4	30	44	6.5	44	9	44	9	44	9	44	9	44	9	44	9	44	9
P26	80	=	=	65	40	M5	12	3.5	40	44	6.5	44	9	44	9	44	9	44	9	44	9	44	9	44	9
P27	=	80	110	82.02	36.8	M6	14	10	36.8	46	8.5	46	11	46	11	46	11	46	11	46	11	46	11	46	11
P28	=	90	120	100	80	6.5	28	4	45	60	22.5	60	25	60	25	60	25	60	25	60	25	60	25	60	25
P29*	80	=	=	66.67	50	5.5	12	3	45	44	6.5	44	9	44	9	44	9	44	9	44	9	44	9	44	9
P30	=	115	155	130	80	9	13	4	45	45	7.5	45	10	45	10	45	10	45	10	45	10	45	10	45	10
P31*	=	80	105	56	44	M6	14	10	36.8	46	8.5	46	11	46	11	46	11	46	11	46	11	46	11	46	11
P32	=	80	105	90	70	M6	12	3.5	32	44	6.5	44	9	44	9	44	9	44	9	44	9	44	9	44	9
P33	=	130	165	145	110	9	13	4.5	45	45	7.5	45	10	45	10	45	10	45	10	45	10	45	10	45	10
P34	=	90	120	100	80	M6	19	5	45	51	13.5	51	16	51	16	51	16	51	16	51	16	51	16	51	16
P36	=	100	135	115	95	M8	25	4.5	45	57	19.5	57	22	57	22	57	22	57	22	57	22	57	22	57	22
P37	=	85	115	98.99	60	M6	12	3.5	32	44	6.5	44	9	44	9	44	9	44	9	44	9	44	9	44	9
P38	80	=	=	70	50	M5	12	4	45	44	6.5	44	9	44	9	44	9	44	9	44	9	44	9	44	9
P39	=	90	120	100	80	6.5	13	4.5	45	45	7.5	45	10	45	10	45	10	45	10	45	10	45	10	45	10
P40	=	80	90	75	60	M6	12	3.5	45	44	6.5	44	9	44	9	44	9	44	9	44	9	44	9	44	9
P42	=	110	145	125.72	55.5	M8	28	3	45	60	22.5	60	25	60	25	60	25	60	25	60	25	60	25	60	25
P44*	=	80	105	90	70	6	13	5	32	45	7.5	45	10	45	10	45	10	45	10	45	10	45	10	45	10
P46	=	100	135	115	95	8.5	17	8	45	49	11.5	49	14	49	14	49	14	49	14	49	14	49	14	49	14
P47	=	90	120	100	50	M6	12	4.5	45	44	6.5	44	9	44	9	44	9	44	9	44	9	44	9	44	9

* Per assemblare il motore è necessario smontare la flangia dal riduttore (vedere schema di montaggio 2 a pag. 47).

* Before the mounting of the motor it is necessary to remove the flange from the gearbox (see structural arrangement 2 at the top of the page 47).

* Vor dem Einbauen des Motors soll die Getriebeflang abmontiert werden (siehe Bauanleitung 2 auf Seite 47).

EP 120																		Stadi Steps Stufenzahl		
Stadi Steps Stufenzahl	1					2												1	2	
	i	3	4	5	7	10	9	12	15	16	20	25	28	35	40	50	70			100
T _{2N}	120	150	180	150	100	150	180	220	220	220	220	220	220	220	220	220	170	110	n _{1nom}	3000
T _{2A}	190	240	290	220	180	240	290	350	350	350	350	350	350	350	350	350	270	200	n _{1max}	4000
T _{2S}	400	500	600	460	380	500	600	700	700	700	700	700	700	700	700	700	540	400	LpA	< 70
J	Vedi pag. 32 / See page 32 / Siehe auf Seite 32																	Lh	20000	
R _t	32					28	32	30					28					F _{R2}	4500	
R _d	0.96					0.93												F _{A2}	4000	
Kg	7.5					8.0												α _{max}	8' 10'	

F_{R2} Carico radiale nominale in uscita [N] a 100min⁻¹
 F_{A2} Carico assiale in uscita [N] a 100min⁻¹

Rated output radial load [N] at 100min⁻¹
 Output axial load [N] at 100min⁻¹

Nenn-Radiallast an der Abtriebswelle bei 100min⁻¹
 Axiallast an der Abtriebswelle bei 100min⁻¹

2.9 Dimensioni

2.9 Dimensions

2.9 Abmessungen

Dimensioni generali e uscite / General and output dimensions / General-und Abtriebsabmessungen

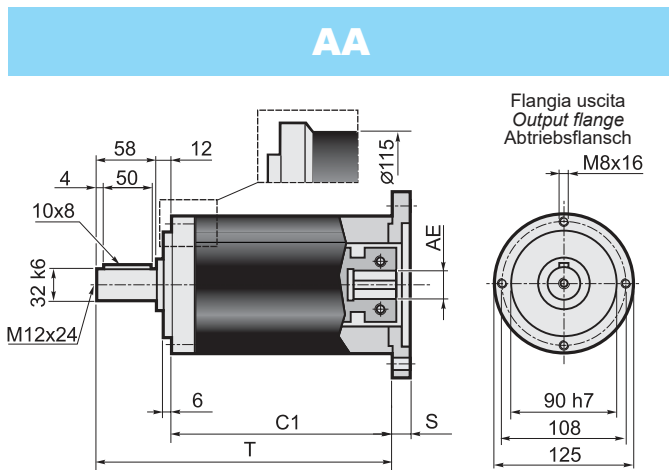

Stadi / Steps / Stufenzahl	1	2	AE= 12.7-14-15.87-16-19
C1	115.8	148.4	
T	185.8	218.4	
Stadi / Steps / Stufenzahl	1	2	AE= 22-24-25-28
C1	134.8	167.4	
T	185.8	218.4	

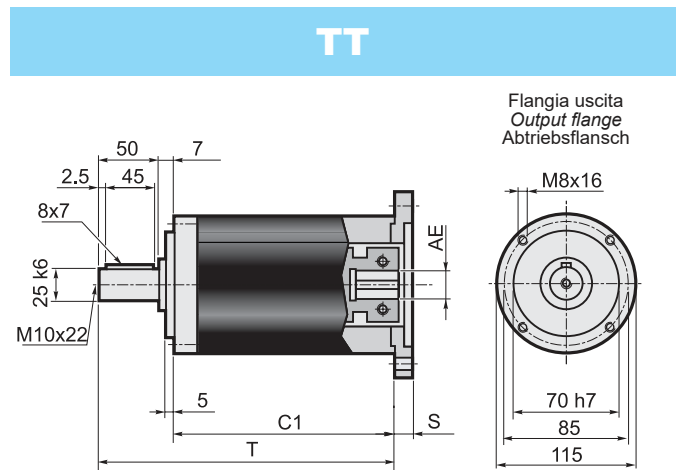

Stadi / Steps / Stufenzahl	1	2	AE= 12.7-14-15.87-16-19
C1	120.8	153.4	
T	177.8	210.4	
Stadi / Steps / Stufenzahl	1	2	AE= 22-24-25-28
C1	139.8	172.4	
T	196.8	229.4	

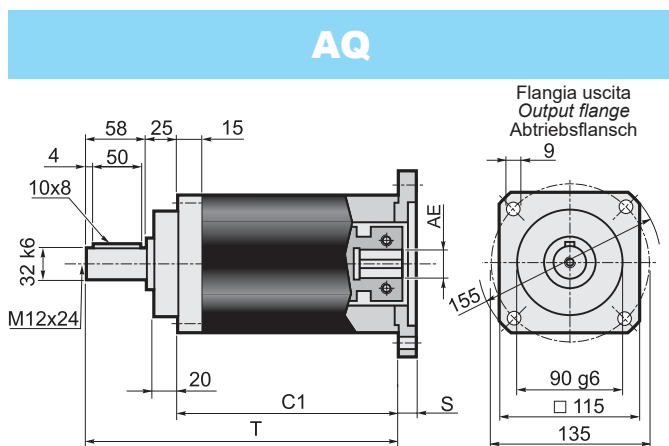

Stadi / Steps / Stufenzahl	1	2	AE= 12.7-14-15.87-16-19
C1	102.8	135.4	
T	185.8	218.4	
Stadi / Steps / Stufenzahl	1	2	AE= 22-24-25-28
C1	121.8	154.4	
T	204.8	237.4	

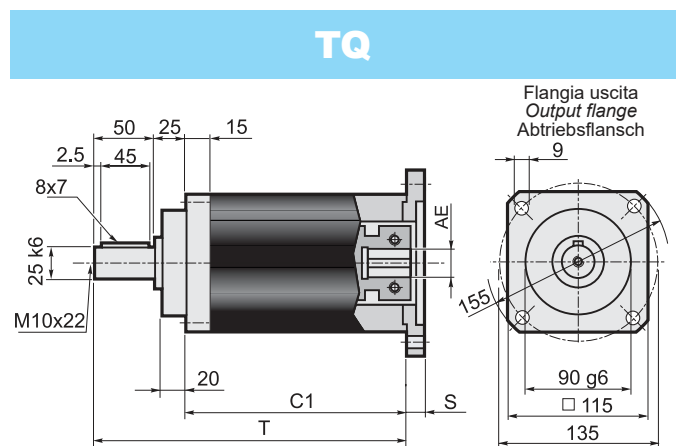

Stadi / Steps / Stufenzahl	1	2	AE= 12.7-14-15.87-16-19
C1	102.8	135.4	
T	177.8	210.4	
Stadi / Steps / Stufenzahl	1	2	AE= 22-24-25-28
C1	121.8	154.4	
T	196.8	229.4	

Dimensioni entrate / Input dimensions / Antriebsabmessungen

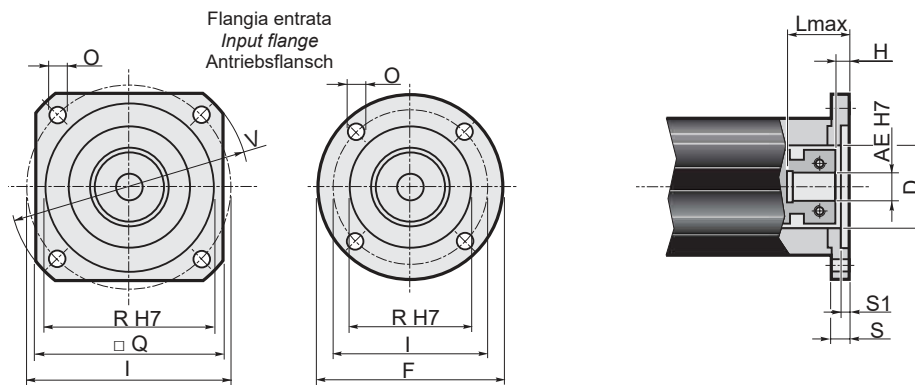

Flange entrata / Input flange / Antriebsflansch										Albero entrata / Input shaft / Antriebswelle																	
										AE																	
										12.7		14		15.87		16		19		22		24		25		28	
F	Q	V	I	R (H7)	O	S	S1	D	L _{max}	H	L _{max}	H	L _{max}	H	L _{max}	H	L _{max}	H	L _{max}	H	L _{max}	H	L _{max}	H			
P01*	=	115	140	125.72	55.52	6.5	13	3	55.52	43	6	43	6	43	6	43	6	43	6	62	6	62	6	62	6	62	6
P02*	115	=	=	75	60	5.5	13	3.5	60	43	6	43	6	43	6	43	6	43	6	62	6	62	6	62	6	62	6
P03*	115	=	=	85	70	6.5	13	3.5	60	43	6	43	6	43	6	43	6	43	6	62	6	62	6	62	6	62	6
P04*	115	=	=	98.42	73.02	6.5	13	3	60	43	6	43	6	43	6	43	6	43	6	62	6	62	6	62	6	62	6
P05*	120	=	=	100	80	6.5	13	4	60	43	6	43	6	43	6	43	6	43	6	62	6	62	6	62	6	62	6
P06*	=	115	140	115	95	9	13	4.5	60	43	6	43	6	43	6	43	6	43	6	62	6	62	6	62	6	62	6
P07	=	115	160	130	110	8.5	13	4.5	60	43	6	43	6	43	6	43	6	43	6	62	6	62	6	62	6	62	6
P08	=	142	190	165	130	11	13	4.5	60	43	6	43	6	43	6	43	6	43	6	62	6	62	6	62	6	62	6
P09	=	192	250	215	180	13	14	4.5	60	44	7	44	7	44	7	44	7	44	7	63	7	63	7	63	7	63	7
P10*	115	=	=	65	50	6.5	13	3.5	50	43	6	43	6	43	6	43	6	43	6	62	6	62	6	62	6	62	6
P11	=	130	170	145	110	M 8	31	7	60	61	24	61	24	61	24	61	24	61	24	80	24	80	24	80	24	80	24
P12	=	130	170	145	110	M 8	17	7	60	47	10	47	10	47	10	47	10	47	10	66	10	66	10	66	10	66	10
P13	=	115	160	130	110	M 8	13	4.5	60	43	6	43	6	43	6	43	6	43	6	62	6	62	6	62	6	62	6
P14*	115	=	=	70	50	6.5	13	3.5	50	43	6	43	6	43	6	43	6	43	6	62	6	62	6	62	6	62	6
P15	115	=	=	90	70	M5	11	3.5	60	41	4	41	4	41	4	41	4	41	4	60	4	60	4	60	4	60	4
P17*	115	=	=	90	70	6.5	13	3.5	60	43	6	43	6	43	6	43	6	43	6	62	6	62	6	62	6	62	6
P18	=	115	155	130	95	8.5	13	4.5	60	43	6	43	6	43	6	43	6	43	6	62	6	62	6	62	6	62	6
P19*	115	=	=	95	50	6.5	13	3.5	50	43	6	43	6	43	6	43	6	43	6	62	6	62	6	62	6	62	6
P20	115	=	=	99	60	M6	13	4	60	43	6	43	6	43	6	43	6	43	6	62	6	62	6	62	6	62	6
P21*	130	=	=	106	82.5	12.5	26.5	15	60	56.5	19.5	56.5	19.5	56.5	19.5	56.5	19.5	56.5	19.5	75.5	19.5	75.5	19.5	75.5	19.5	75.5	19.5
P22	=	144	190	165	110	11	15	4.5	60	45	8	45	8	45	8	45	8	45	8	64	8	64	8	64	8	64	8
P23*	115	=	=	63	40	5.5	11	3.5	40	41	4	41	4	41	4	41	4	41	4	60	4	60	4	60	4	60	4
P24	120	=	=	100	80	M6	18	7	60	48	11	48	11	48	11	48	11	48	11	67	11	67	11	67	11	67	11
P25	=	115	155	115	95	M8	27	4.5	60	57	20	57	20	57	20	57	20	57	20	76	20	76	20	76	20	76	20
P26	=	115	155	131.95	55.52	M8	27	4.5	60	57	20	57	20	57	20	57	20	57	20	76	20	76	20	76	20	76	20
P27	170	=	=	148	114	8.5	13	4	60	43	6	43	6	43	6	43	6	43	6	62	6	62	6	62	6	62	6
P28	=	115	140	115	95	M8	16	6	60	46	9	46	9	46	9	46	9	46	9	65	9	65	9	65	9	65	9
P29	133,5	=	=	121.5	60	M6	13	13	60	43	6	43	6	43	6	43	6	43	6	62	6	62	6	62	6	62	6

* Per assemblare il motore è necessario smontare la flangia dal riduttore (vedere schema di montaggio 2 a pag. 47).

* Before the mounting of the motor it is necessary to remove the flange from the gearbox (see structural arrangement 2 at the top of the page 47).

* Vor dem Einbauen des Motors soll die Getriebeflang abmontiert werden (siehe Bauanleitung 2 auf Seite 47).

2.8 Dati tecnici

2.8 Technical data

2.8 Technische Daten

EP 155																		Stadi Steps Stufenzahl	
Stadi Steps Stufenzahl	1					2												1	2
i	3	4	5	7	10	9	12	15	16	20	25	28	35	40	50	70	100	1	2
T _{2N}	240	320	380	300	220	320	400	500	500	500	500	500	500	500	500	350	250	n _{1nom}	3000
T _{2A}	420	540	600	480	400	480	600	750	750	750	750	750	750	750	750	560	460	n _{1max}	4000
T _{2S}	880	1140	1260	1000	850	1000	1250	1500	1500	1500	1500	1500	1500	1500	1500	1120	920	L _{pA}	< 70
J	Vedi pag. 33 / See page 33 / Siehe auf Seite 33																	L _h	20000
R _t	60				50	60											50	F _{R2} (AA) F _{R2} (TT)	6500 5300
R _d	0.96					0.93												F _{A2} (AA) F _{A2} (TT)	3250 2650
Kg	10.9					15.7												α _{max}	8' 10'

F_{R2} Carico radiale nominale in uscita [N] a 100min⁻¹
F_{A2} Carico assiale in uscita [N] a 100min⁻¹

Rated output radial load [N] at 100min⁻¹
Output axial load [N] at 100min⁻¹

Nenn-Radiallast an der Abtriebswelle bei 100min⁻¹
Axiallast an der Abtriebswelle bei 100min⁻¹

2.9 Dimensioni

2.9 Dimensions

2.9 Abmessungen

Dimensioni generali e uscite / General and output dimensions / General-und Abtriebsabmessungen

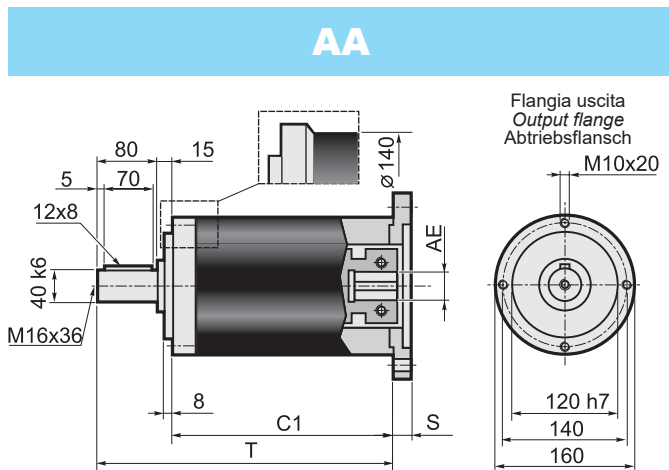

Stadi / Steps / Stufenzahl	1	2	AE= 15.87-16-19-22-24
C1	156	197.5	
T	251	292.5	
Stadi / Steps / Stufenzahl	1	2	AE= 28-32-35-38
C1	181	222.5	
T	276	317.5	

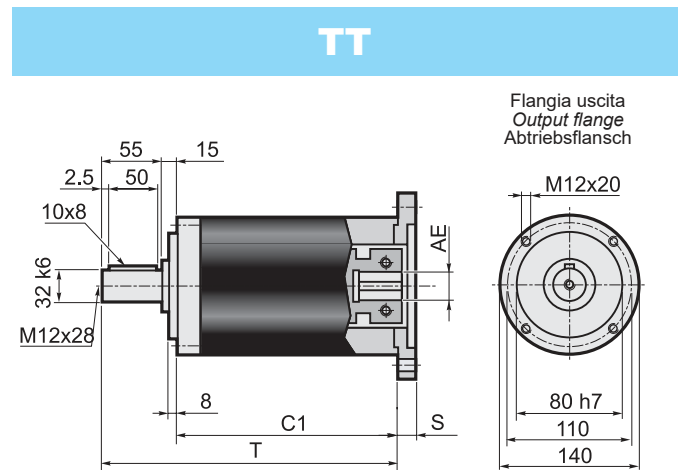

Stadi / Steps / Stufenzahl	1	2	AE= 15.87-16-19-22-24
C1	156	197.5	
T	226	267.5	
Stadi / Steps / Stufenzahl	1	2	AE= 28-32-35-38
C1	181	222.5	
T	251	292.5	

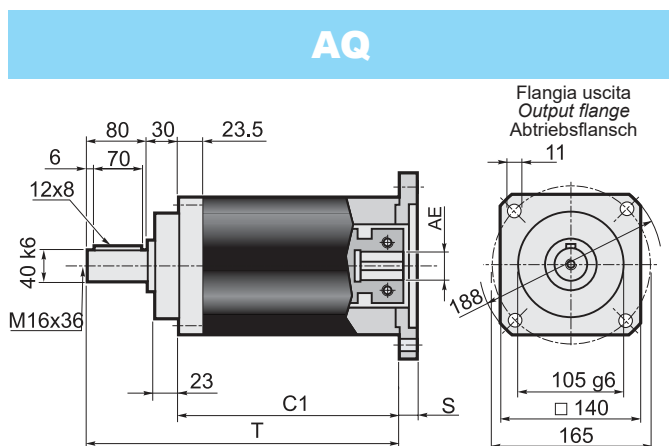

Stadi / Steps / Stufenzahl	1	2	AE= 15.87-16-19-22-24
C1	141	182.5	
T	251	292.5	
Stadi / Steps / Stufenzahl	1	2	AE= 28-32-35-38
C1	166	207.5	
T	276	317.5	

Dimensioni entrate / Input dimensions / Antriebsabmessungen

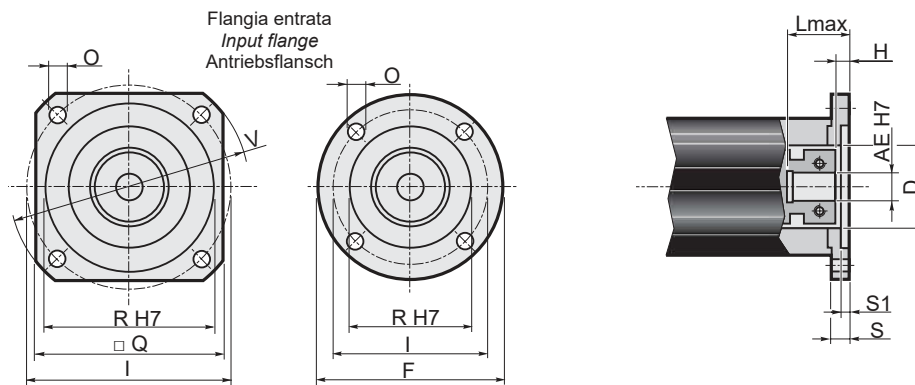

Flange entrata / Input flange / Antriebsflansch										Albero entrata / Input shaft / Antriebswelle																	
										AE																	
										15.87		16		19		22		24		28		32		35		38	
F	Q	V	I	R (H7)	O	S	S1	D	L _{max}	H	L _{max}	H	L _{max}	H	L _{max}	H	L _{max}	H	L _{max}	H	L _{max}	H	L _{max}	H			
P01*	140	=	=	125.72	55.52	6.5	15	4	55.52	57.8	6.8	57.8	6.8	57.8	6.8	57.8	6.8	57.8	6.8	82.8	7.3	82.8	7.3	82.8	7.3	82.8	7.3
P02*	140	=	=	100	80	6.5	15	4	70	57.8	6.8	57.8	6.8	57.8	6.8	57.8	6.8	57.8	6.8	82.8	7.3	82.8	7.3	82.8	7.3	82.8	7.3
P03*	140	=	=	115	95	8.5	15	4.5	70	57.8	6.8	57.8	6.8	57.8	6.8	57.8	6.8	57.8	6.8	82.8	7.3	82.8	7.3	82.8	7.3	82.8	7.3
P04*	=	140	160	130	110	8.5	15	4.5	70	57.8	6.8	57.8	6.8	57.8	6.8	57.8	6.8	57.8	6.8	82.8	7.3	82.8	7.3	82.8	7.3	82.8	7.3
P05	=	142	190	165	130	11	15	4.5	70	57.8	6.8	57.8	6.8	57.8	6.8	57.8	6.8	57.8	6.8	82.8	7.3	82.8	7.3	82.8	7.3	82.8	7.3
P06	=	190	250	215	180	13	15	4.5	70	57.8	6.8	57.8	6.8	57.8	6.8	57.8	6.8	57.8	6.8	82.8	7.3	82.8	7.3	82.8	7.3	82.8	7.3
P07	=	250	300	265	230	13	15	4.5	70	57.8	6.8	57.8	6.8	57.8	6.8	57.8	6.8	57.8	6.8	82.8	7.3	82.8	7.3	82.8	7.3	82.8	7.3
P08	=	130	165	145	110	M 8	18	7	70	60.8	9.8	60.8	9.8	60.8	9.8	60.8	9.8	60.8	9.8	85.8	10.3	85.8	10.3	85.8	10.3	85.8	10.3
P09	=	180	230	200	114.3	13.5	22	11	70	64.8	13.8	64.8	13.8	64.8	13.8	64.8	13.8	64.8	13.8	89.8	14.3	89.8	14.3	89.8	14.3	89.8	14.3
P10	=	115	150	130	95	M 8	15	4.5	70	57.8	6.8	57.8	6.8	57.8	6.8	57.8	6.8	57.8	6.8	82.8	7.3	82.8	7.3	82.8	7.3	82.8	7.3
P11	=	180	230	198	155	13.5	22	7	120x11	64.8	13.8	64.8	13.8	64.8	13.8	64.8	13.8	64.8	13.8	89.8	14.3	89.8	14.3	89.8	14.3	89.8	14.3
P12	=	220	270	235	200	13.5	15	5	70	57.8	6.8	57.8	6.8	57.8	6.8	57.8	6.8	57.8	6.8	82.8	7.3	82.8	7.3	82.8	7.3	82.8	7.3
P13	=	190	250	215	130	13	15	4.5	70	57.8	6.8	57.8	6.8	57.8	6.8	57.8	6.8	57.8	6.8	82.8	7.3	82.8	7.3	82.8	7.3	82.8	7.3
P14	=	142	190	165	110	11	15	4.5	70	57.8	6.8	57.8	6.8	57.8	6.8	57.8	6.8	57.8	6.8	82.8	7.3	82.8	7.3	82.8	7.3	82.8	7.3
P15*	150	=	=	90	70	6.5	15	4	70	57.8	6.8	57.8	6.8	57.8	6.8	57.8	6.8	57.8	6.8	82.8	7.3	82.8	7.3	82.8	7.3	82.8	7.3
P16	=	146	200	177.8	114.3	10.5	15	3.5	70	57.8	6.8	57.8	6.8	57.8	6.8	57.8	6.8	57.8	6.8	82.8	7.3	82.8	7.3	82.8	7.3	82.8	7.3
P17	=	130	165	145	110	M 8	28	7	70	70.8	19.8	70.8	19.8	70.8	19.8	70.8	19.8	70.8	19.8	95.8	20.3	95.8	20.3	95.8	20.3	95.8	20.3
P18	140	=	=	100	80	M 6	22	6	70	64.8	13.8	64.8	13.8	64.8	13.8	64.8	13.8	64.8	13.8	89.8	14.3	89.8	14.3	89.8	14.3	89.8	14.3
P19	=	130	165	145	110	M 8	27	7	70	69.8	18.8	69.8	18.8	69.8	18.8	69.8	18.8	69.8	18.8	94.8	19.3	94.8	19.3	94.8	19.3	94.8	19.3

* Per assemblare il motore è necessario smontare la flangia dal riduttore (vedere schema di montaggio 2 a pag. 47).

* Before the mounting of the motor it is necessary to remove the flange from the gearbox (see structural arrangement 2 at the top of the page 47).

* Vor dem Einbauen des Motors soll die Getriebeflangens abmontiert werden (siehe Bauanleitung 2 auf Seite 47).

1 Schema di montaggio / Assembly drawing / Bauanleitung 1

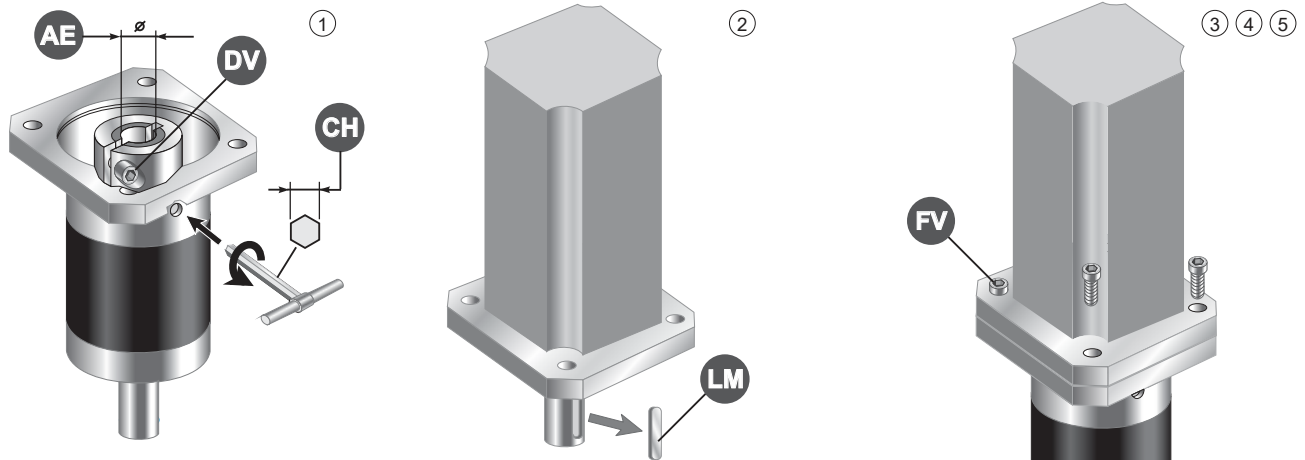

- 1 - Allentare la vite di serraggio del morsetto (DV)
- 2 - Estrarre la linguetta (LM) dall'albero motore
- 3 - Pulire le superfici di contatto delle flange motore e riduttore
- 4 - Calettare il motore sul riduttore evitando urti
- 5 - Stringere le viti di assemblaggio (FV) in modo alternato
- 6 - Assicurarsi che il morsetto venga serrato posizionandolo verso il motore e rispettando la fasatura dei tagli
- 7 - Serrare la vite (o le viti) del morsetto (DV) alla coppia (CS) indicata in tabella

- 1 - Unloose the fastening screw (or screws) of the clamp (DV)
- 2 - Remove the key (LM) from motor shaft
- 3 - Clean the contact surfaces of motor flange/gearbox flange
- 4 - Avoid impacts while fitting motor to gearbox
- 5 - Tighten the assembling screws (FV) alternately
- 6 - Fix the clamp towards the motor and tighten it in compliance with the cuts timing
- 7 - Tighten the clamp screw, or screws (DV) according to the torque (CS) reported in the table

- 1 - die Befestigungsschraube der Klammer (DV) lockern
- 2 - die Feder (LM) aus Motorwelle ziehen
- 3 - die Motorflansch / Getriebeflansch Kontaktfläche reinigen
- 4 - Motor und Getriebe ohne Stöße verkeilen
- 5 - die Befestigungsschrauben (FV) abwechselnd anziehen
- 6 - Die Klammer soll zum Motor angezogen. Dabei soll die Zuendeinstellung der Schnitte geachtet
- 7 - die Schraube (oder Schrauben) der Klammer (DV) zu dem in der Tabelle angegebenen Anzugsmoment anziehen

EP 55	AE	6	6.35	7	8	9	9.52	11				
	DV	M4 x 16										
	NV	1										
	CH	3										
	CS [Nm]	4.8										
EP 75	AE	6	6.35	7	8	9	9.52	11	12	12.7	14	
	DV	M4 x 16										
	NV	1										
	CH	3										
	CS [Nm]	4.8										
EP 90	AE	9	9.52	11	12	12.7	14	15.87	16	19		
	DV	M4 x 16						M5 x 20				
	NV	1						1				
	CH	3						4				
	CS [Nm]	4.8						9.4				
EP 120	AE	12.7	14	15.87	16	19	22	24	25	28		
	DV	M4 x 16		M5 x 20			M6 x 20					
	NV	1		1			2					
	CH	3		4			5					
	CS [Nm]	4.8		9.4			16.2					
EP 155	AE	15.87	16	19	22	24	28	32	35	38		
	DV	M6 x 20			M6 x 20			M6 x 20				
	NV	1			2			3				
	CH	5			5			5				
	CS [Nm]	16.2			16.2			16.2				

Tutte le viti hanno classe di resistenza 12.9
 All screws supplied according to strenght class 12.9
 Alle Schrauben nach Festigkeitsklasse 12.9 geliefert

AE= Albero entrata / Input shaft / Antriebswelle
 DV= Diametro vite / Screw diameter / Schraubendurchmesser

NV= Numero viti / Number of screw / Schraubenanzahl
 CS= Coppia di serraggio / Setting torque / Spannungsmoment

2.10 Istruzioni per il montaggio del motore

2.10 Instructions for assembly of motor

2.10 Anleitung für motormontage

2 Schema di montaggio / Assembly drawing / Bauanleitung 2

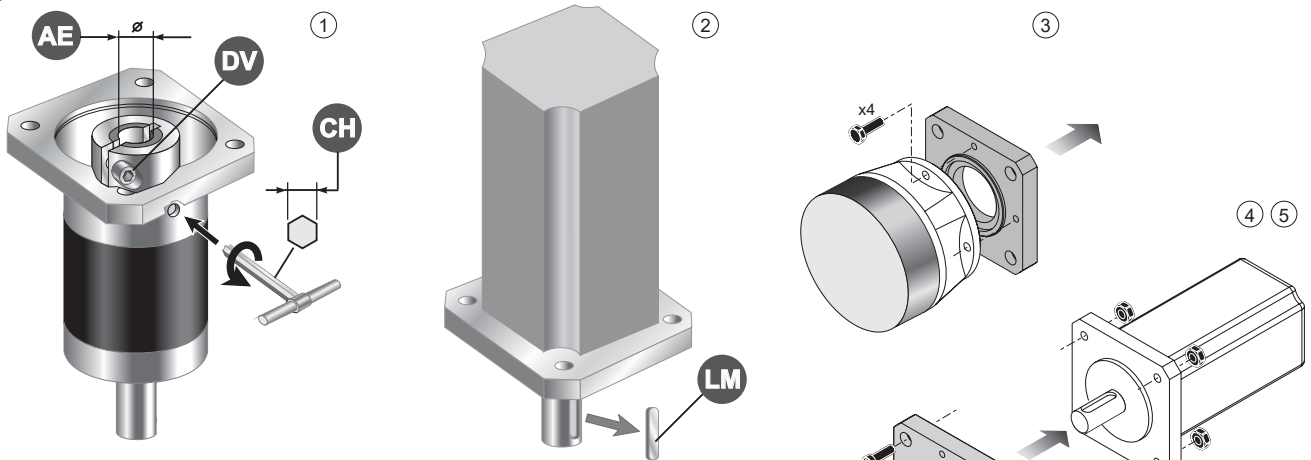

- 1 - Allentare la vite di serraggio del morsetto (DV)
- 2 - Estrarre la linguetta (LM) dall'albero motore
- 3 - Smontare la flangia dal riduttore
- 4 - Pulire le superfici di contatto delle flange motore e riduttore
- 5 - Fissare la flangia sul motore
- 6 - Calettare il motore sul riduttore evitando urti
- 7 - Stringere le viti di assemblaggio (FV) in modo alternato
- 8 - Assicurarsi che il morsetto venga serrato posizionandolo verso il motore e rispettando la fasatura dei tagli
- 9 - Serrare la vite (o le viti) del morsetto (DV) alla coppia (CS) indicata in tabella

- 1 - Unloose the fastening screw (or screws) of the clamp (DV)
- 2 - Remove the key (LM) from motor shaft
- 3 - Remove the flange from the gearbox
- 4 - Clean the contact surfaces of motor flange/gearbox flange
- 5 - Fix the flange on the motor
- 6 - Avoid impacts while fitting motor to gearbox
- 7 - Tighten the assembling screws (FV) alternatively
- 8 - Fix the clamp towards the motor and tighten it in compliance with the cuts timing
- 9 - Tighten the clamp screw, or screws (DV) according to the torque (CS) reported in the table

- 1 - die Befestigungsschraube der Klammer (DV) lockern
- 2 - die Feder (LM) aus Motorwelle ziehen
- 3 - die Flansch von Getriebe abmontieren
- 4 - die Motorflansch / Getriebe-flansch Kontaktfläche reinigen
- 5 - die Flansch an Motor befestigen
- 6 - Motor und Getriebe ohne Stöße verkeilen
- 7 - die Befestigungsschrauben (FV) abwechselnd anziehen
- 8 - Die Klammer soll zum Motor angezogen. Dabei soll die Zuendeinstellung de Schnitte geachtet
- 9 - die Schraube (oder Schrauben) der Klammer (DV) zu dem in der Tabelle angegebenen Anzugsmoment anziehen

EP 55	AE	6	6.35	7	8	9	9.52	11					
	DV	M4 x 16											
	NV	1											
	CH	3											
	CS [Nm]	4.8											
EP 75	AE	6	6.35	7	8	9	9.52	11	12	12.7	14		
	DV	M4 x 16											
	NV	1											
	CH	3											
	CS [Nm]	4.8											
EP 90	AE	9	9.52	11	12	12.7	14	15.87	16	19			
	DV	M4 x 16								M5 x 20			
	NV	1								1			
	CH	3								4			
	CS [Nm]	4.8								9.4			
EP 120	AE	12.7	14	15.87	16	19	22	24	25	28			
	DV	M4 x 16			M5 x 20				M6 x 20				
	NV	1			1				2				
	CH	3			4				5				
	CS [Nm]	4.8			9.4				16.2				
EP 155	AE	15.87	16	19	22	24	28	32	35	38			
	DV	M6 x 20			M6 x 20				M6 x 20				
	NV	1			2				3				
	CH	5			5				5				
	CS [Nm]	16.2			16.2				16.2				

Tutte le viti hanno classe di resistenza 12.9

All screws supplied according to strenght class 12.9

Alle Schrauben nach Festigkeitsklasse 12.9 geliefert

AE= Albero entrata / Input shaft / Antriebswelle

DV= Diametro vite / Screw diameter / Schraubendurchmesser

NV= Numero viti / Number of screw / Schraubenanzahl

CS= Coppia di serraggio / Setting torque / Spannungsmoment

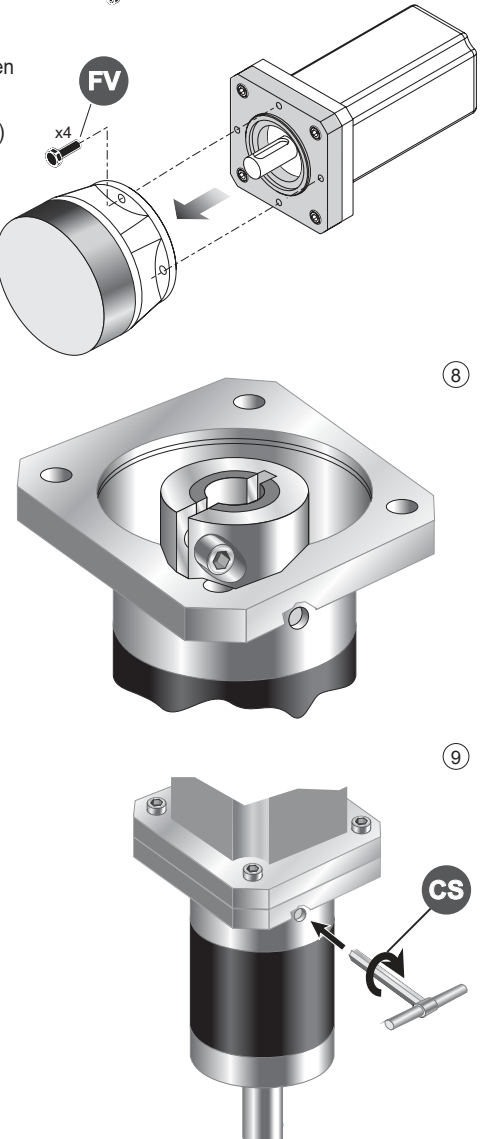

3.0	RIDUTTORI EPICICLOIDALI ANGOLARI SERIE TEP	RIGHT ANGLE PLANETARY GEARBOXES TEP SERIES	WINKEL-PLANETENGETRIEBE SERIE TEP	
3.1	Caratteristiche	<i>Characteristics</i>	Merkmale	50
3.2	Designazione	<i>Designation</i>	Bezeichnung	51
3.3	Selezione	<i>Selection</i>	Getriebeauswahl	51
3.4	Gioco angolare	<i>Backlash</i>	Spiel	51
3.5	Sensi di rotazione alberi	<i>Direction of shaft rotation</i>	Drehrichtungen der Wellen	52
3.6	Carichi radiali e assiali su albero lento	<i>Radial and axial loads on output shaft</i>	Radial-und Axiallasten an der Ausgangswelle	52
3.7	Lubrificazione	<i>Lubrication</i>	Schmierung	52
3.8	Momento d'inerzia	<i>Moment of inertia</i>	Trägheitsmoment	53
3.9	Dati tecnici	<i>Technical data</i>	Technische Daten	56
3.10	Dimensioni	<i>Dimensions</i>	Abmessungen	56
3.11	Istruzioni per il montaggio del motore	<i>Instructions for the motor assembling</i>	Anleitung für Motoranbau	66

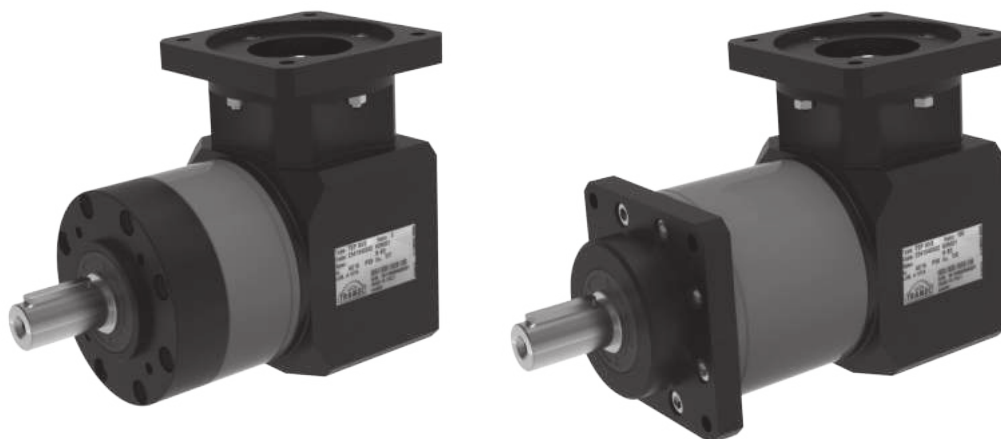

3.1 Caratteristiche

La serie di riduttori epicicloidali angolari TEP è il risultato di un ottimo rapporto tra economicità del prezzo e garanzia di precisione delle caratteristiche di funzionamento.

I nostri riduttori sono stati realizzati per un utilizzo prevalente sulle seguenti applicazioni:

- Macchine utensili
- Macchine per la lavorazione del legno
- Linee transfer
- Macchine da stampa
- Macchine automatiche per confezionamento ed imballaggio
- Automazioni
- Manipolatori
- Macchine serigrafiche
- Guide lineari

La gamma dei riduttori è costituita da 5 grandezze (55, 75, 90, 120 e 155), a 2 e 3 stadi di riduzione, ognuna con due tipi di alberi uscita (tipo A e tipo T) e flange uscita di tipo A, T e Q.

Corpo: costruito in acciaio nitrurato, garantisce robustezza e una elevata affidabilità nel tempo.

Flange: le flange in entrata ed in uscita sono costruite in alluminio e sono disponibili in molteplici varianti costruttive.

Alberi: sono costruiti in acciaio legato bonificato.

Ingranaggi: in acciaio legato da cementazione e tempra, con dentature rettificata.

Cuscinetti: di elevata qualità opportunamente dimensionati per garantire elevate durate e silenziosità di funzionamento.

3.1 Characteristics

The right angle planetary gearboxes TEP series is the result of the outstanding ratio competitive price / precision guaranteed with regard to operating features.

Our gearboxes are manufactured for prevailing utilization in the following applications:

- *Machine tools*
- *Woodworking machines*
- *Transfer machines*
- *Printing machines*
- *Automatic packing and packaging machines*
- *Automation*
- *Mechanical hands*
- *Silk-screen process machines*
- *Linear guides*

The TEP series is available in 5 sizes (55, 75, 90, 120 and 155), with 2 or 3 reduction stages, with two types of output shaft (A and T) and three types of output flange (A, T and Q).

Housing: *made of special nitrided steel to assure strength, high reliability and long life.*

Flanges: *input and output flanges made of aluminium and available in several versions.*

Shafts: *made of hardened and tempered alloy steel.*

Gears: *made of casehardened and tempered alloy steel, with ground toothing.*

Bearings: *high quality and suitably sized to assure long life and noiseless working.*

3.1 Merkmale

Die TEP Serie von Winkel-planetengeräten ist das Ergebnis des hervorragenden Verhältnis guten Preis / garantierte Präzision der Betriebseigenschaften.

Unsere Getriebe sind für überwiegende Verwendung in der folgenden Applikationen hergestellt:

- Werkzeugmaschinen
- Holzbearbeitungsmaschinen
- Transfermaschinen
- Druckmaschinen
- Automatische Verpackungsmaschinen
- Automation
- Manipulatoren
- Siebdruckmaschinen
- Linearführungen

Die TEP Serie ist in 5 Größen (55, 75, 90, 120 und 155) mit 2 oder 3 Untersetzungsstufen, mit zwei Typen von Abtriebswellen (A und T) und drei Typen von Abtriebsflanschen (A, T und Q) verfügbar.

Gehäuse: aus Spezial-Nitrierstahl. Garantiert Robustheit und dauerhaft hohe Zuverlässigkeit.

Ein- u. Ausgangsflansche: aus Aluminium, in zahlreichen Varianten lieferbar.

Wellen: aus vergütetem Legierungsstahl.

Zahnräder: aus Einsatzstahl mit geschliffenen Zahnflanken.

Lager: sind hochwertig und zweckmäßig bemessen, um eine lange Lebensdauer und einen geräuscharmen Lauf zu garantieren.

3.2 Designazione

3.2 Designation

3.2 Bezeichnung

Riduttore epicicloidale angolare <i>Right angle planetary gearbox</i> Winkel-planetengetriebe	Grandezza <i>Size</i> Größe	Numero di stadi <i>Steps</i> Untersetzungsstufen	Angolare <i>Right angle</i> Winkelgetriebe	Rapporto di riduzione <i>Ratio</i> Untersetzungsverhältnis	Albero uscita <i>Output shaft</i> Durchmesser Abtriebswelle	Flangia uscita <i>Output flange</i> Abtriebsflansch	Albero entrata <i>Input shaft</i> Antriebswelle	Flangia in entrata <i>Input flange</i> Eingangsflansch	Posizione di montaggio <i>Mounting position</i> Baulage
TEP	55	2	T	100	A	A	AE..	P..	B5
	55 75 90 120 155	2 3	T	3 - 100	A T	A T Q	Vedi tabelle <i>See tables</i> Siehe Tab.	Vedi tabelle <i>See tables</i> Siehe Tab.	B5 B6 B8 V1 V3 OS

3.3 Selezione

3.3 Selection

3.3 Getriebeauswahl

Per la selezione dei riduttori epicicloidali EP, seguire la procedura descritta al paragrafo a pag. 6.

Make the selection of the planetary gearboxes EP Series as described at paragraph page 6.

Die Wahl der Planetengetriebe Serie EP wird wie im Abschnitt Seite 6.

3.4 Gioco angolare (α_{max})

3.4 Backlash (α_{max})

3.4 Spiel (α_{max})

Gioco massimo [arcmin] misurato sull'albero uscita, con albero entrata bloccato applicando una coppia pari al 2% della coppia nominale.

Max. backlash measured on output shaft by torque equals to 2% of the nominal torque value with input shaft blocked.

Maximales Spiel [arcmin], gemessen an der Abtriebswelle bei blockierter Eingangswelle mit 2% des Nennmoments.

3.5 Sensi di rotazione alberi

3.5 Direction of shaft rotation

3.5 Drehrichtungen der Wellen

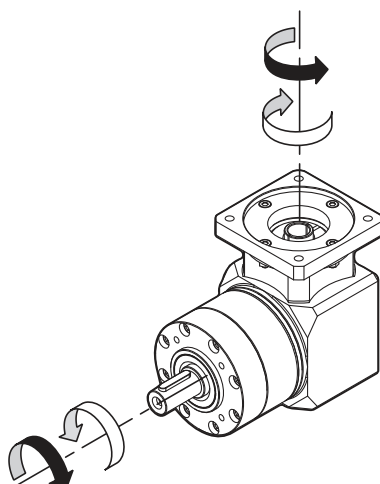

3.6 Carichi radiali e assiali su albero lento

Nella tabella delle prestazioni sono indicati i valori, espressi in N, dei carichi assiali e radiali ammissibili alle diverse velocità per una durata dei cuscinetti di 20.000 ore. Il carico radiale F_{R2} si considera applicato ad una distanza dalla battuta pari alla metà della lunghezza dell'albero lento. Per distanze y diverse, è possibile calcolare il nuovo carico massimo ammissibile F_{R2Y} utilizzando formula e coefficienti indicati nella tabella.

3.6 Radial and axial loads on output shaft

The table of performances shows admissible axial and radial load values expressed in N for different speeds and for a bearing life of 20.000 hours. Radial load F_{R2} calculations have been based on loads applied to the center line of the output shaft extension. For different y distance it is possible to calculate the new maximum admissible load by using formula and coefficient shown in the table.

3.6 Radial-und Axiallasten an der Abtriebswelle

Die Leistungstabelle enthält die in N ausgedrückten Werte der Axial- und Radiallasten für verschiedene Umdrehungszahlen. Diesen Werten liegt eine Lebensdauer der Lager von 20.000 Stunden zugrunde. Die Radiallast F_{R2} greift hierbei auf der Mitte der Abtriebswelle an. Greift die Radiallast an einem anderen Punkt der Abtriebswelle an, so kann man die zulässige Radiallast mit der folgenden Formel sowie den dazugehörigen Koeffizienten berechnen:

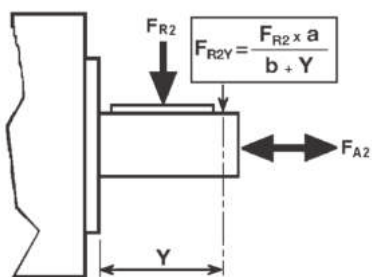

	TEP 55	TEP 75	TEP 90	TEP 120	TEP 155
a	27	46	56	77	95
b	18	32	39	52	64

3.7 Lubrificazione

I riduttori TEP sono forniti completi di lubrificante a vita pertanto non necessitano di manutenzione. In fase di ordine specificare la posizione di montaggio.

3.7 Lubrication

TEP gearboxes are supplied filled with long-life lubricant and do not require any maintenance. When ordering it is important to specify the exact mounting position.

3.7 Schmierung

Die Planetengetriebe TEP werden inklusive Dauerschmierung geliefert und sind wartungsfrei. Bei der Bestellung bitte die Einbauposition angeben.

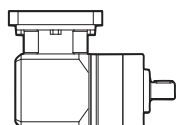

B5

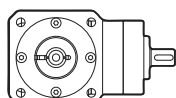

B6

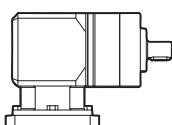

B8

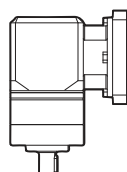

V1

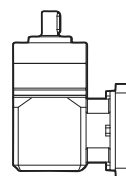

V3

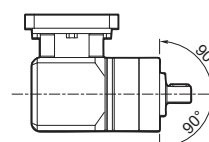

OS

3.8 Momento d'inerzia J
[kg·cm²]

3.8 Moment of inertia J
[kg·cm²]

3.8 Trägheitsmoment J
[kg·cm²]

TEP 55								
Albero entrata / Input shaft / Antriebswelle								
Stadi Steps Stufenzahl	i	6	6.35	7	8	9	9.525	11
2	3	0.13	0.13	0.13	0.14	0.14	0.14	0.15
	4	0.12	0.12	0.12	0.13	0.13	0.13	0.13
	5	0.11	0.11	0.11	0.13	0.13	0.13	0.13
	7	0.11	0.11	0.11	0.12	0.12	0.12	0.13
	10	0.11	0.11	0.11	0.12	0.12	0.12	0.13
3	9	0.13	0.13	0.13	0.14	0.14	0.14	0.15
	12	0.13	0.13	0.13	0.14	0.14	0.14	0.14
	15	0.13	0.13	0.13	0.14	0.14	0.14	0.14
	16	0.12	0.12	0.12	0.13	0.13	0.13	0.13
	20	0.12	0.12	0.12	0.13	0.13	0.13	0.13
	25	0.11	0.11	0.11	0.13	0.13	0.13	0.13
	28	0.11	0.11	0.11	0.12	0.12	0.12	0.13
	35	0.11	0.11	0.11	0.12	0.12	0.12	0.13
	40	0.11	0.11	0.11	0.12	0.12	0.12	0.13
	50	0.11	0.11	0.11	0.12	0.12	0.12	0.13
	70	0.11	0.11	0.11	0.12	0.12	0.12	0.13
100	0.11	0.11	0.11	0.12	0.12	0.12	0.13	

TEP 75											
Albero entrata / Input shaft / Antriebswelle											
Stadi Steps Stufenzahl	i	6	6.35	7	8	9	9.525	11	12	12.7	14
2	3	0.33	0.33	0.33	0.34	0.34	0.34	0.35	0.36	0.36	0.37
	4	0.27	0.27	0.27	0.29	0.29	0.29	0.30	0.30	0.30	0.32
	5	0.26	0.26	0.26	0.28	0.28	0.28	0.29	0.29	0.29	0.31
	7	0.25	0.25	0.25	0.26	0.26	0.26	0.28	0.28	0.28	0.30
	10	0.24	0.24	0.24	0.26	0.26	0.26	0.27	0.27	0.27	0.29
3	9	0.32	0.32	0.32	0.33	0.33	0.33	0.34	0.35	0.35	0.36
	12	0.31	0.31	0.31	0.33	0.33	0.33	0.34	0.34	0.34	0.36
	15	0.31	0.31	0.31	0.33	0.32	0.32	0.34	0.34	0.34	0.36
	16	0.27	0.27	0.27	0.29	0.29	0.29	0.30	0.30	0.30	0.32
	20	0.27	0.27	0.27	0.29	0.29	0.29	0.30	0.30	0.30	0.32
	25	0.26	0.26	0.26	0.27	0.27	0.27	0.28	0.29	0.29	0.31
	28	0.25	0.25	0.25	0.26	0.26	0.26	0.28	0.28	0.28	0.30
	35	0.25	0.25	0.25	0.26	0.26	0.26	0.28	0.28	0.28	0.30
	40	0.24	0.24	0.24	0.26	0.26	0.26	0.27	0.27	0.27	0.29
	50	0.24	0.24	0.24	0.26	0.26	0.26	0.27	0.27	0.27	0.29
	70	0.24	0.24	0.24	0.26	0.26	0.26	0.27	0.27	0.27	0.29
100	0.24	0.24	0.24	0.26	0.26	0.26	0.27	0.27	0.27	0.29	

I valori dei momenti d'inerzia riportati si riferiscono all'albero entrata.

The moment of inertia values refer to the input shaft.

Die Werte der Trägheitsmoment beziehen sich auf die Antriebswelle.

3.8 Momento d'inerzia J
[kg·cm²]

3.8 Moment of inertia J
[kg·cm²]

3.8 Trägheitsmoment J
[kg·cm²]

		TEP 90									
		Albero entrata / Input shaft / Antriebswelle									
Stadi Steps Stufenzahl	i	9	9.525	11	12	12.7	14	15.87	16	19	
2	3	1.14	1.14	1.15	1.16	1.15	1.17	1.37	1.37	1.34	
	4	0.96	0.96	0.97	0.98	0.98	1.00	1.19	1.19	1.16	
	5	0.90	0.90	0.91	0.91	0.91	0.93	1.13	1.13	1.10	
	7	0.85	0.85	0.86	0.87	0.86	0.88	1.08	1.08	1.05	
	10	0.83	0.83	0.84	0.84	0.84	0.86	1.06	1.06	1.03	
3	9	1.15	1.14	1.15	1.16	1.16	1.18	1.38	1.37	1.34	
	12	1.13	1.12	1.14	1.14	1.14	1.16	1.36	1.35	1.32	
	15	1.12	1.12	1.13	1.13	1.13	1.15	1.35	1.35	1.32	
	16	0.95	0.95	0.96	0.97	0.97	0.99	1.18	1.18	1.15	
	20	0.95	0.95	0.96	0.96	0.96	0.98	1.18	1.18	1.15	
	25	0.89	0.89	0.90	0.91	0.90	0.92	1.12	1.12	1.09	
	28	0.85	0.85	0.86	0.86	0.86	0.88	1.08	1.08	1.05	
	35	0.85	0.85	0.86	0.86	0.86	0.88	1.08	1.08	1.04	
	40	0.83	0.82	0.83	0.84	0.84	0.86	1.05	1.05	1.02	
	50	0.82	0.82	0.83	0.84	0.84	0.86	1.05	1.05	1.02	
	70	0.82	0.82	0.83	0.84	0.84	0.86	1.05	1.05	1.02	
100	0.82	0.82	0.83	0.84	0.84	0.86	1.05	1.05	1.02		

		TEP 120						
		Albero entrata / Input shaft / Antriebswelle						
Stadi Steps Stufenzahl	i	14	15.87	16	19	22	24	28
2	3	3.97	4.14	4.14	4.10	6.25	6.21	6.06
	4	3.08	3.25	3.25	3.21	5.36	5.32	5.17
	5	2.80	2.97	2.97	2.94	5.08	5.04	4.89
	7	2.57	2.74	2.74	2.70	4.85	4.81	4.66
	10	2.45	2.62	2.62	2.59	4.73	4.69	4.54
3	9	3.95	4.12	4.12	4.08	6.23	6.19	6.04
	12	3.86	4.03	4.03	4.00	6.14	6.10	5.96
	15	3.82	3.99	3.99	3.96	6.10	6.06	5.92
	16	3.02	3.19	3.19	3.15	5.30	5.26	5.11
	20	2.99	3.16	3.16	3.13	5.28	5.24	5.09
	25	2.74	2.92	2.91	2.88	5.03	4.99	4.84
	28	2.55	2.72	2.72	2.69	4.83	4.79	4.64
	35	2.54	2.71	2.71	2.68	4.82	4.78	4.64
	40	2.44	2.61	2.61	2.58	4.72	4.68	4.53
	50	2.43	2.60	2.60	2.57	4.72	4.68	4.53
	70	2.43	2.60	2.60	2.57	4.72	4.68	4.53
100	2.43	2.60	2.60	2.57	4.72	4.67	4.53	

I valori dei momenti d'inerzia riportati si riferiscono all'albero entrata.

The moment of inertia values refer to the input shaft.

Die Werte der Trägheitsmoment beziehen sich auf die Antriebswelle.



3.8 Momento d'inerzia J
[kg·cm²]

3.8 Moment of inertia J
[kg·cm²]

3.8 Trägheitsmoment J
[kg·cm²]

		TEP 155								
		Albero entrata / Input shaft / Antriebswelle								
Stadi Steps Stufenzahl	i	15.87	16.00	19	22	24	28	32	35	38
2	3	11.69	11.69	11.72	12.96	12.93	16.93	18.77	18.64	18.31
	4	9.17	9.17	9.20	10.44	10.40	14.41	16.24	16.12	15.79
	5	8.29	8.29	8.32	9.56	9.52	13.52	15.36	15.23	14.91
	7	7.58	7.58	7.61	8.85	8.81	12.81	14.65	14.53	14.20
	10	7.21	7.21	7.24	8.48	8.44	12.45	14.28	14.16	13.83
3	9	11.56	11.56	11.59	12.83	12.79	16.79	18.63	18.51	18.18
	12	11.27	11.27	11.31	12.55	12.51	16.51	18.35	18.23	17.90
	15	11.18	11.18	11.21	12.45	12.41	16.42	18.25	18.13	17.80
	16	8.94	8.94	8.97	10.21	10.17	14.17	16.01	15.89	15.56
	20	8.88	8.88	8.91	10.15	10.12	14.12	15.96	15.83	15.50
	25	8.10	8.10	8.13	9.37	9.34	13.34	15.18	15.05	14.72
	28	7.50	7.50	7.53	8.77	8.74	12.74	14.58	14.45	14.12
	35	7.48	7.48	7.51	8.75	8.72	12.72	14.56	14.43	14.10
	40	7.17	7.17	7.20	8.44	8.41	12.41	14.25	14.12	13.79
	50	7.16	7.16	7.19	8.43	8.40	12.40	14.24	14.11	13.78
	70	7.16	7.16	7.19	8.43	8.39	12.39	14.23	14.10	13.78
100	7.15	7.15	7.18	8.42	8.39	12.39	14.23	14.10	13.77	

I valori dei momenti d'inerzia riportati si riferiscono all'albero entrata.

The moment of inertia values refer to the input shaft.

Die Werte der Trägheitsmoment beziehen sich auf die Antriebswelle.

TEP 55																		Stadi Steps Stufenzahl	
Stadi Steps Stufenzahl	2					3												2	3
i	3	4	5	7	10	9	12	15	16	20	25	28	35	40	50	70	100		
T _{2N}	9	12	15	12	10	14	16	16	16	16	16	16	16	16	16	14	12	n _{1nom}	3500
T _{2A}	13	17	22	22	20	24	28	28	28	28	28	28	28	28	28	24	22	n _{1max}	5000
T _{2S}	26	34	44	44	40	48	56	56	56	56	56	56	56	56	56	48	44	L _{pA}	< 65
J	Vedi pag. 53 / See page 53 / Siehe auf Seite 53																	L _h	20000
R _t	0.85					0.8		0.85								0.8		F _{R2}	300
R _d	0.94					0.91												F _{A2}	450
K _g	1.3					2.3												α _{max}	17' 20'

F_{R2} Carico radiale nominale in uscita [N] a 100min⁻¹
 F_{A2} Carico assiale in uscita [N] a 100min⁻¹

Rated output radial load [N] at 100min⁻¹
 Output axial load [N] at 100min⁻¹

Nenn-Radiallast an der Abtriebswelle bei 100min⁻¹
 Axiallast an der Abtriebswelle bei 100min⁻¹

3.10 Dimensioni

3.10 Dimensions

3.10 Abmessungen

Dimensioni generali e uscite / General and output dimensions / General-und Abtriebsabmessungen

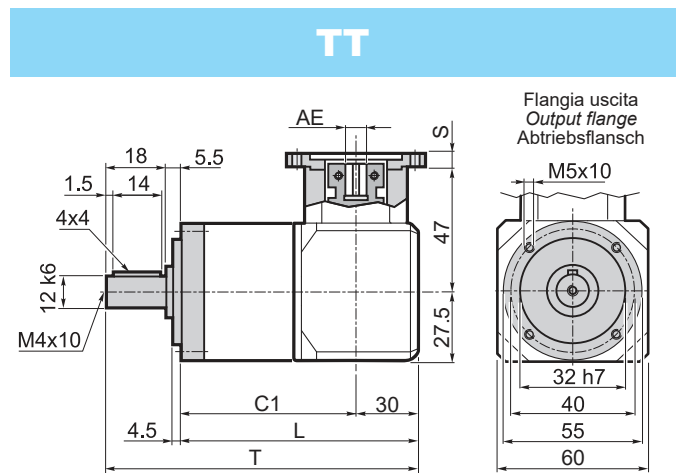
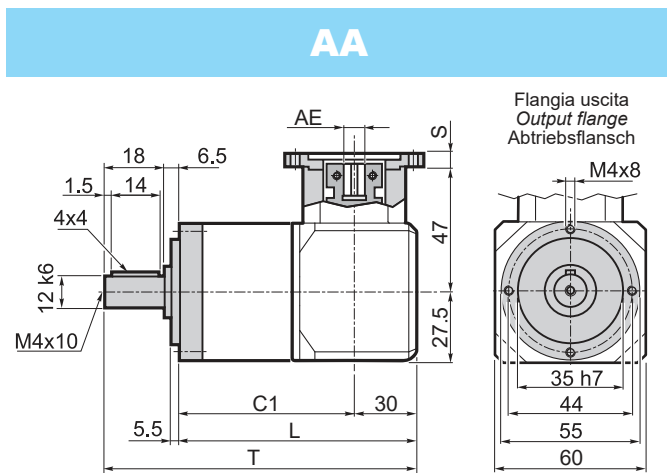

Stadi / Steps / Stufenzahl	2	3
C1	65	84
L	95	114
T	119.5	138.5

AE= 6 - 6.35 - 7 - 8 - 9 - 9.52 - 11

Stadi / Steps / Stufenzahl	2	3
C1	66	85
L	96	115
T	119.5	138.5

AE= 6 - 6.35 - 7 - 8 - 9 - 9.52 - 11

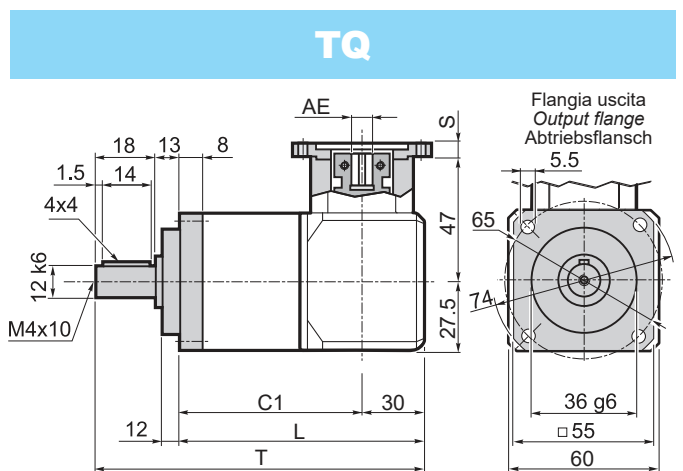
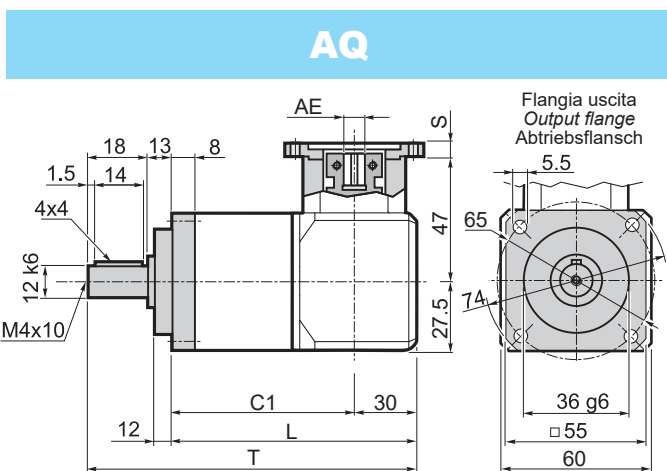

Stadi / Steps / Stufenzahl	2	3
C1	58.5	77.5
L	88.5	107.5
T	119.5	138.5

AE= 6 - 6.35 - 7 - 8 - 9 - 9.52 - 11

Stadi / Steps / Stufenzahl	2	3
C1	58.5	77.5
L	88.5	107.5
T	119.5	138.5

AE= 6 - 6.35 - 7 - 8 - 9 - 9.52 - 11

Dimensioni entrate / Input dimensions / Antriebsabmessungen

Flangia entrata
Input flange
Antriebsflansch

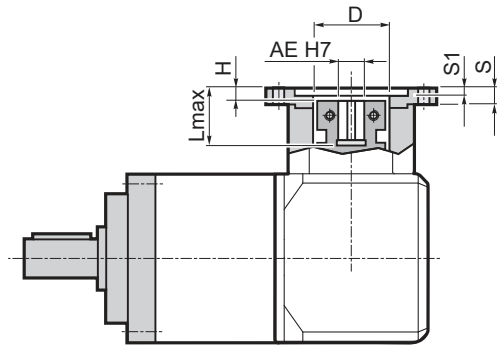
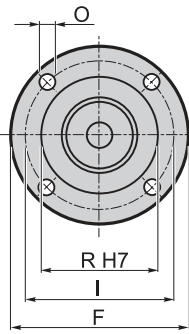
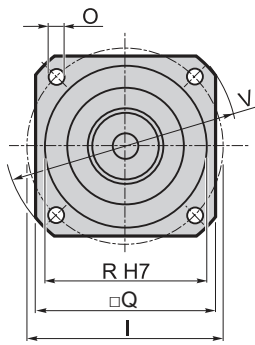

	Flange entrata / Input flange / Antriebsflansch									Albero entrata / Input shaft / Antriebswelle													
										AE													
	F	Q	V	I	R (H7)	O	S	S1	D	6		6.35		7		8		9		9.52		11	
L max										H	L max	H	L max	H	L max	H	L max	H	L max	H	L max	H	L max
P01*	60	=	=	43.82	22	4.5	10	3	22	30	7	30	7	30	7	30	7	30	7	30	7	30	7
P02*	=	60	80	66.67	38.1	5.5	10	3	32	30	7	30	7	30	7	30	7	30	7	30	7	30	7
P03*	=	60	80	63	40	5.5	10	3.5	32	30	7	30	7	30	7	30	7	30	7	30	7	30	7
P04	=	70	90	75	60	6.5	10.5	3.5	32	30.5	7.5	30.5	7.5	30.5	7.5	30.5	7.5	30.5	7.5	30.5	7.5	30.5	7.5
P05	105	=	=	85	70	6.5	10.5	3.5	32	30.5	7.5	30.5	7.5	30.5	7.5	30.5	7.5	30.5	7.5	30.5	7.5	30.5	7.5
P06	=	80	110	98.42	73.02	6	11	3.5	35	31	8	31	8	31	8	31	8	31	8	31	8	31	8
P07	=	95	120	100	80	6.5	11.5	4	32	31.5	8.5	31.5	8.5	31.5	8.5	31.5	8.5	31.5	8.5	31.5	8.5	31.5	8.5
P08	=	98	130	115	95	9	11.5	4	32	31.5	8.5	31.5	8.5	31.5	8.5	31.5	8.5	31.5	8.5	31.5	8.5	31.5	8.5
P09	=	116	160	130	110	9	12	4.5	32	32	9	32	9	32	9	32	9	32	9	32	9	32	9
P10*	60	=	=	39	26	4.5	10	3	26	30	7	30	7	30	7	30	7	30	7	30	7	30	7
P11*	60	=	=	42	32	4.5	10	3	32	30	7	30	7	30	7	30	7	30	7	30	7	30	7
P12*	65	=	=	46	32	4.5	10	3.5	32	30	7	30	7	30	7	30	7	30	7	30	7	30	7
P13*	80	=	=	65	50	5.5	10	3.5	32	30	7	30	7	30	7	30	7	30	7	30	7	30	7
P14*	60	=	=	39	20	4.5	10	2.5	20	30	7	30	7	30	7	30	7	30	7	30	7	30	7
P15	=	75	100	90	60	5.8	12	3.5	32	32	9	32	9	32	9	32	9	32	9	32	9	32	9
P16*	60	=	=	45	30	3.5	14	7	30	34	11	34	11	34	11	34	11	34	11	34	11	34	11
P17	=	60	82	70	50	4.5	16.5	8	32	36.5	13.5	36.5	13.5	36.5	13.5	36.5	13.5	36.5	13.5	36.5	13.5	36.5	13.5
P18	=	60	80	60	50	M4	10.5	3.5	32	30.5	7.5	30.5	7.5	30.5	7.5	30.5	7.5	30.5	7.5	30.5	7.5	30.5	7.5
P19*	60	=	=	36	25	4.5	10	3	25	30	7	30	7	30	7	30	7	30	7	30	7	30	7
P20	=	60	82	70	50	5.5	10.5	3.5	32	30.5	7.5	30.5	7.5	30.5	7.5	30.5	7.5	30.5	7.5	30.5	7.5	30.5	7.5
P21*	60	=	=	46	30	4.5	10	3	30	30	7	30	7	30	7	30	7	30	7	30	7	30	7
P22	=	60	80	70.71	36	4.5	10	2	32	30	7	30	7	30	7	30	7	30	7	30	7	30	7
P23	=	62	85	70	50	5.5	15.5	3.5	32	35.5	12.5	35.5	12.5	35.5	12.5	35.5	12.5	35.5	12.5	35.5	12.5	35.5	12.5
P24	=	75	100	90	70	5.8	12	3.5	32	32	9	32	9	32	9	32	9	32	9	32	9	32	9
P25	=	70	95	85	55	5.8	12	3.5	32	32	9	32	9	32	9	32	9	32	9	32	9	32	9
P26*	=	60	80	65.5	34	5.5	10	3.5	33	30	7	30	7	30	7	30	7	30	7	30	7	30	7
P27	=	80	110	95	50	6.5	12	3.5	32	32	9	32	9	32	9	32	9	32	9	32	9	32	9
P28	=	60	80	66.67	38.1	M4	9	2.5	32	29	6	29	6	29	6	29	6	29	6	29	6	29	6
P29	60	=	=	45	30	M3	11	4	32	31	8	31	8	31	8	31	8	31	8	31	8	31	8
P30	=	70	95	85	60	5.8	12	3.5	32	32	9	32	9	32	9	32	9	32	9	32	9	32	9
P31	=	62	85	70	50	M4	11	3.5	32	31	8	31	8	31	8	31	8	31	8	31	8	31	8
P32	=	60	80	65	40	M5	10	3.5	32	30	7	30	7	30	7	30	7	30	7	30	7	30	7
P33	=	85	115	99	60	5.5	11	3.5	35	31	8	31	8	31	8	31	8	31	8	31	8	31	8
P34	=	65	87	73.54	40	M4	10	3.5	32	30	7	30	7	30	7	30	7	30	7	30	7	30	7
P35	=	60	80	70.71	36	M4	14	2	32	34	11	34	11	34	11	34	11	34	11	34	11	34	11
P36	=	85	115	98.42	73.02	6	15	3.5	35	35	12	35	12	35	12	35	12	35	12	35	12	35	12
P37	=	95	120	100	80	6.5	16.5	5	32														
P38	60	=	=	48	30	M3	11	7	32	31	8	31	8	31	8	31	8	31	8	31	8	31	8
P41*	68	=	=	50	30	5.5	10	10	30	30	7	30	7	30	7	30	7	30	7	30	7	30	7
P43	=	60	80	66.67	50	M5	9	2.5	32	29	6	29	6	29	6	29	6	29	6	29	6	29	6
P44*	60	=	=	32	25	4.5	9	2.5	20	29	6	29	6	29	6	29	6	29	6	29	6	29	6
P45	=	62	85	73.54	50	M5	10	3	32	30	7	30	7	30	7	30	7	30	7	30	7	30	7
P46	70	=	=	55	45	4.5	9	3	32	29	6	29	6	29	6	29	6	29	6	29	6	29	6
P47	=	90	118	104	83	6.5	14	3.5	32	34	11	34	11	34	11	34	11	34	11	34	11	34	11
P48*	60	=	=	38.88	25	4.5	10	3	25	30	7	30	7	30	7	30	7	30	7	30	7	30	7
P49	=	70	90	75	60	M5	10.5	3.5	32	30.5	7.5	30.5	7.5	30.5	7.5	30.5	7.5	30.5	7.5	30.5	7.5	30.5	7.5

* Per assemblare il motore è necessario smontare la flangia dal riduttore (vedere schema di montaggio 2 a pag. 67).

* Before the mounting of the motor it is necessary to remove the flange from the gearbox (see structural arrangement 2 at the top of the page 67).

* Vor dem Einbauen des Motors soll die Getriebeflang abmontiert werden (siehe Bauanleitung 2 auf Seite 67).

TEP 75																		Stadi Steps Stufenzahl			
Stadi Steps Stufenzahl	2					3												2	3		
	i	3	4	5	7	10	9	12	15	16	20	25	28	35	40	50	70			100	
T _{2N}	18	25	30	28	20	26	32	36	36	36	36	36	36	36	36	30	22	n _{1nom}	3000		
T _{2A}	30	40	50	45	40	50	60	60	60	60	60	60	60	60	60	50	45	n _{1max}	4500		
T _{2S}	60	80	100	90	80	100	120	120	120	120	120	120	120	120	120	100	90	LpA	< 68		
J	Vedi pag. 53 / See page 53 / Siehe auf Seite 53																	Lh	20000		
R _t	2.5					2		2.5										2		F _{R2}	1800
R _d	0.94					0.91												F _{A2}	1400		
Kg	2.4					3												α _{max}	15' 18'		

F_{R2} Carico radiale nominale in uscita [N] a 100min⁻¹
 F_{A2} Carico assiale in uscita [N] a 100min⁻¹

Rated output radial load [N] at 100min⁻¹
 Output axial load [N] at 100min⁻¹

Nenn-Radiallast an der Abtriebswelle bei 100min⁻¹
 Axiallast an der Abtriebswelle bei 100min⁻¹

3.10 Dimensioni

3.10 Dimensions

3.10 Abmessungen

Dimensioni generali e uscite / General and output dimensions / General-und Abtriebsabmessungen

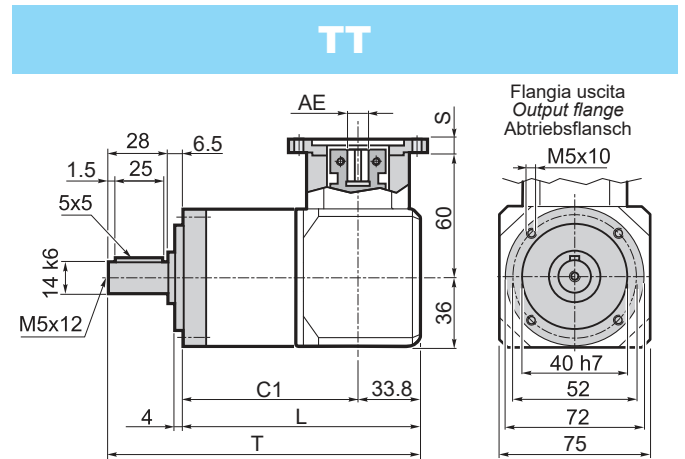
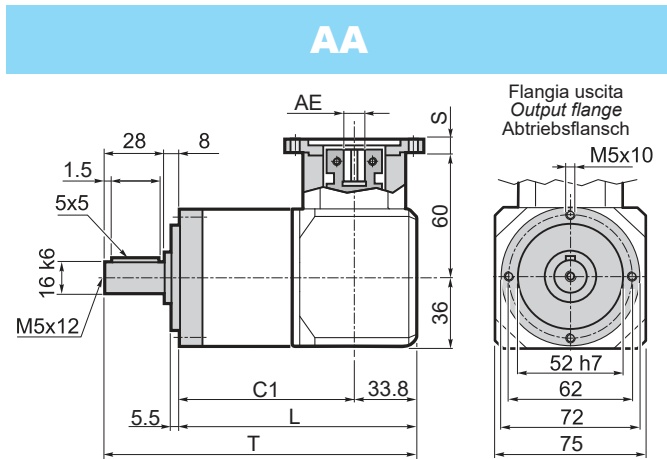

Stadi / Steps / Stufenzahl	2	3	AE=	
C1	84.7	107.2		6-6.35-7-8-9-9.52-11-12-12.7-14
L	118.5	141		
T	154.5	177		

Stadi / Steps / Stufenzahl	2	3	AE=	
C1	86.2	108.7		6-6.35-7-8-9-9.52-11-12-12.7-14
L	120	142.5		
T	154.5	177		

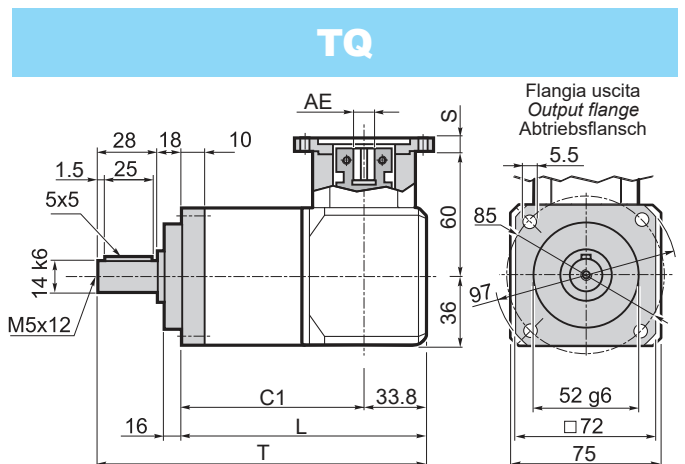
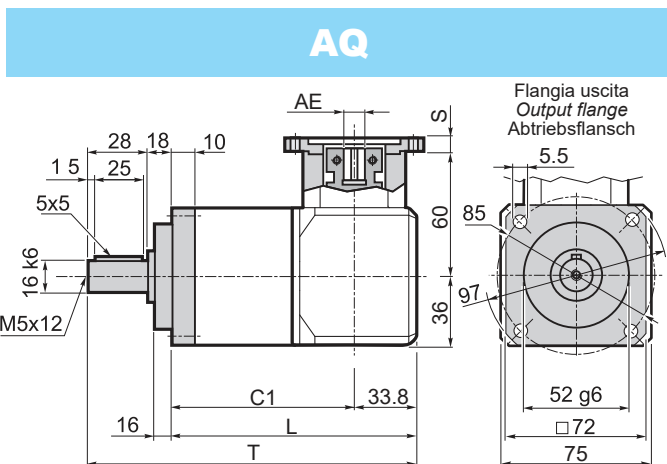

Stadi / Steps / Stufenzahl	2	3	AE=	
C1	74.7	97.2		6-6.35-7-8-9-9.52-11-12-12.7-14
L	108.5	131		
T	154.5	177		

Stadi / Steps / Stufenzahl	2	3	AE=	
C1	74.7	97.2		6-6.35-7-8-9-9.52-11-12-12.7-14
L	108.5	131		
T	154.5	177		

Dimensioni entrate / Input dimensions / Antriebsabmessungen

Flangia entrata
Input flange
Antriebsflansch

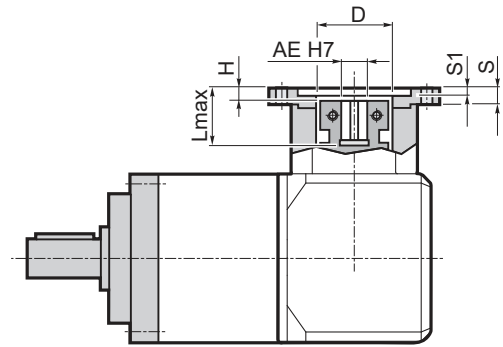
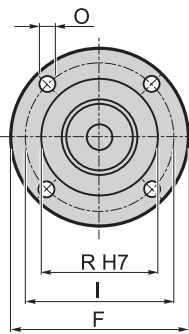
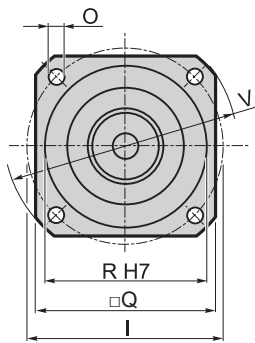

Flange entrata / Input flange / Antriebsflansch										Albero entrata / Input shaft / Antriebswelle																	
										AE																	
										6		6.35		7		8		9		9.52		11		12		12.7	
F	Q	V	I	R (H7)	O	S	S1	D	L _{max}	H	L _{max}	H	L _{max}	H	L _{max}	H	L _{max}	H	L _{max}	H	L _{max}	H	L _{max}	H	L _{max}	H	
P01*	60	=	=	43.82	22	4.5	10	3	22	35	4.5	35	4.5	35	4.5	26	6.5	26	6.5	35	6.5	26	6.5	35	6.5	35	6.5
P02*	=	60	80	66.67	38.1	5.5	10	3	32	35	4.5	35	4.5	35	4.5	26	6.5	26	6.5	35	6.5	26	6.5	35	6.5	35	6.5
P03*	=	60	80	63	40	5.5	10	3.5	32	35	4.5	35	4.5	35	4.5	26	6.5	26	6.5	35	6.5	26	6.5	35	6.5	35	6.5
P04	=	70	90	75	60	6.5	10.5	3.5	32	35.5	5	35.5	5	35.5	5	26.5	7	26.5	7	35.5	7	26.5	7	35.5	7	35.5	7
P05	105	=	=	85	70	6.5	10.5	3.5	32	35.5	5	35.5	5	35.5	5	26.5	7	26.5	7	35.5	7	26.5	7	35.5	7	35.5	7
P06	=	80	110	98.42	73.02	6	11	3.5	35	36	5.5	36	5.5	36	5.5	27	7.5	27	7.5	36	7.5	27	7.5	36	7.5	36	7.5
P07	=	95	120	100	80	6.5	11.5	4	32	36.5	6	36.5	6	36.5	6	27.5	8	27.5	8	36.5	8	27.5	8	36.5	8	36.5	8
P08	=	98	130	115	95	9	11.5	4	32	36.5	6	36.5	6	36.5	6	27.5	8	27.5	8	36.5	8	27.5	8	36.5	8	36.5	8
P09	=	116	160	130	110	9	12	4.5	32	37	6.5	37	6.5	37	6.5	28	8.5	28	8.5	37	8.5	28	8.5	37	8.5	37	8.5
P10*	60	=	=	39	26	4.5	10	3	26	35	4.5	35	4.5	35	4.5	26	6.5	26	6.5	35	6.5	26	6.5	35	6.5	35	6.5
P11*	60	=	=	42	32	4.5	10	3	32	35	4.5	35	4.5	35	4.5	26	6.5	26	6.5	35	6.5	26	6.5	35	6.5	35	6.5
P12*	65	=	=	46	32	4.5	10	3.5	32	35	4.5	35	4.5	35	4.5	26	6.5	26	6.5	35	6.5	26	6.5	35	6.5	35	6.5
P13*	80	=	=	65	50	5.5	10	3.5	32	35	4.5	35	4.5	35	4.5	26	6.5	26	6.5	35	6.5	26	6.5	35	6.5	35	6.5
P14*	60	=	=	39	20	4.5	10	2.5	20	35	4.5	35	4.5	35	4.5	26	6.5	26	6.5	35	6.5	26	6.5	35	6.5	35	6.5
P15	=	75	100	90	60	5.8	12	3.5	32	37	6.5	37	6.5	37	6.5	28	8.5	28	8.5	37	8.5	28	8.5	37	8.5	37	8.5
P16*	60	=	=	45	30	3.5	14	7	30	39	8.5	39	8.5	39	8.5	30	10.5	30	10.5	39	10.5	30	10.5	39	10.5	39	10.5
P17	=	60	82	70	50	4.5	16.5	8	32	41.5	11	41.5	11	41.5	11	32.5	13	32.5	13	41.5	13	32.5	13	41.5	13	41.5	13
P18	=	60	80	60	50	M4	10.5	3.5	32	35.5	5	35.5	5	35.5	5	26.5	7	26.5	7	35.5	7	26.5	7	35.5	7	35.5	7
P19*	60	=	=	36	25	4.5	10	3	25	35	4.5	35	4.5	35	4.5	26	6.5	26	6.5	35	6.5	26	6.5	35	6.5	35	6.5
P20	=	60	82	70	50	5.5	10.5	3.5	32	35.5	5	35.5	5	35.5	5	26.5	7	26.5	7	35.5	7	26.5	7	35.5	7	35.5	7
P21*	60	=	=	46	30	4.5	10	3	30	35	4.5	35	4.5	35	4.5	26	6.5	26	6.5	35	6.5	26	6.5	35	6.5	35	6.5
P22	=	60	80	70.71	36	4.5	10	2	32	35	4.5	35	4.5	35	4.5	26	6.5	26	6.5	35	6.5	26	6.5	35	6.5	35	6.5
P23	=	62	85	70	50	5.5	15.5	3.5	32	40.5	10	40.5	10	40.5	10	31.5	12	31.5	12	40.5	12	31.5	12	40.5	12	40.5	12
P24	=	75	100	90	70	5.8	12	3.5	32	37	6.5	37	6.5	37	6.5	28	8.5	28	8.5	37	8.5	28	8.5	37	8.5	37	8.5
P25	=	70	95	85	55	5.8	12	3.5	32	37	6.5	37	6.5	37	6.5	28	8.5	28	8.5	37	8.5	28	8.5	37	8.5	37	8.5
P26*	=	60	80	65.5	34	5.5	10	3.5	33	35	4.5	35	4.5	35	4.5	26	6.5	26	6.5	35	6.5	26	6.5	35	6.5	35	6.5
P27	=	80	110	95	50	6.5	12	3.5	32	37	6.5	37	6.5	37	6.5	28	8.5	28	8.5	37	8.5	28	8.5	37	8.5	37	8.5
P28	=	60	80	66.67	38.1	M4	9	2.5	32	34	3.5	34	3.5	34	3.5	25	5.5	25	5.5	34	5.5	25	5.5	34	5.5	34	5.5
P29	60	=	=	45	30	M3	11	4	32	36	5.5	36	5.5	36	5.5	27	7.5	27	7.5	36	7.5	27	7.5	36	7.5	36	7.5
P30	=	70	95	85	60	5.8	12	3.5	32	37	6.5	37	6.5	37	6.5	28	8.5	28	8.5	37	8.5	28	8.5	37	8.5	37	8.5
P31	=	62	85	70	50	M4	11	3.5	32	36	5.5	36	5.5	36	5.5	27	7.5	27	7.5	36	7.5	27	7.5	36	7.5	36	7.5
P32	=	60	80	65	40	M5	10	3.5	32	35	4.5	35	4.5	35	4.5	26	6.5	26	6.5	35	6.5	26	6.5	35	6.5	35	6.5
P33	=	85	115	99	60	5.5	11	3.5	32	36	5.5	36	5.5	36	5.5	27	7.5	27	7.5	36	7.5	27	7.5	36	7.5	36	7.5
P34	=	65	87	73.54	40	M4	10	3.5	32	35	4.5	35	4.5	35	4.5	26	6.5	26	6.5	35	6.5	26	6.5	35	6.5	35	6.5
P35	=	60	80	70.71	36	M4	14	2	32	39	8.5	39	8.5	39	8.5	30	10.5	30	10.5	39	10.5	30	10.5	39	10.5	39	10.5
P36	=	85	115	98.42	73.02	6	15	3.5	35	40	9.5	40	9.5	40	9.5	35	11.5	35	11.5	40	11.5	35	11.5	40	11.5	40	11.5
P37	=	95	120	100	80	6.5	16.5	5	32	41.5	11	41.5	11	41.5	11	32.5	13	32.5	13	41.5	13	32.5	13	41.5	13	41.5	13
P38	60	=	=	48	30	M3	11	7	32	36	5.5	36	5.5	36	5.5	27	7.5	27	7.5	36	7.5	27	7.5	36	7.5	36	7.5
P41*	68	=	=	50	30	5.5	10	10	30	35	4.5	35	4.5	35	4.5	26	6.5	26	6.5	35	6.5	26	6.5	35	6.5	35	6.5
P43	=	60	80	66.67	50	M5	9	2.5	32	34	3.5	34	3.5	34	3.5	25	5.5	25	5.5	34	5.5	25	5.5	34	5.5	34	5.5
P44*	60	=	=	32	25	4.5	9	2.5	20	34	3.5	34	3.5	34	3.5	25	5.5	25	5.5	34	5.5	25	5.5	34	5.5	34	5.5
P45	=	62	85	73.54	50	M5	10	3	32	35	4.5	35	4.5	35	4.5	26	6.5	26	6.5	35	6.5	26	6.5	35	6.5	35	6.5
P46	70	=	=	55	45	4.5	9	3	32	34	3.5	34	3.5	34	3.5	25	5.5	25	5.5	34	5.5	25	5.5	34	5.5	34	5.5
P47	=	90	118	104	83	6.5	14	3.5	32	39	8.5	39	8.5	39	8.5	30	10.5	30	10.5	39	10.5	30	10.5	39	10.5	39	10.5
P48	60	=	=	38.88	25	4.5	10	3	25	35	4.5	35	4.5	35	4.5	26	6.5	26	6.5	35	6.5	26	6.5	35	6.5	35	6.5
P49	=	70	90	75	60	M5	10.5	3.5	32	35.5	5	35.5	5	35.5	5	26.5	7	26.5	7	35.5	7	26.5	7	35.5	7	35.5	7

* Per assemblare il motore è necessario smontare la flangia dal riduttore (vedere schema di montaggio 2 a pag. 67).

* Before the mounting of the motor it is necessary to remove the flange from the gearbox (see structural arrangement 2 at the top of the page 67).

* Vor dem Einbauen des Motors soll die Getriebeflange abmontiert werden (siehe Bauanleitung 2 auf Seite 67).

TEP 90																		Stadi Steps Stufenzahl		
Stadi Steps Stufenzahl	2					3												2	3	
	i	3	4	5	7	10	9	12	15	16	20	25	28	35	40	50	70			100
T _{2N}	32	42	54	55	50	65	70	75	75	75	75	75	75	75	75	65	55	n _{1nom}	3000	
T _{2A}	50	66	84	90	80	100	110	120	120	120	120	120	120	120	120	100	90	n _{1max}	4500	
T _{2S}	100	132	168	180	160	200	220	240	240	240	240	240	240	240	240	200	180	LpA	< 68	
J	Vedi pag. 54 / See page 54 / Siehe auf Seite 54																	Lh	20000	
R _t	6.5					6					6.5					6			F _{R2}	2600
R _d	0.94					0.91												F _{A2}	2000	
Kg	4.6					5.5												α _{max}	15' 18'	

F_{R2} Carico radiale nominale in uscita [N] a 100min⁻¹
 F_{A2} Carico assiale in uscita [N] a 100min⁻¹

Rated output radial load [N] at 100min⁻¹
 Output axial load [N] at 100min⁻¹

Nenn-Radiallast an der Abtriebswelle bei 100min⁻¹
 Axiallast an der Abtriebswelle bei 100min⁻¹

3.10 Dimensioni

3.10 Dimensions

3.10 Abmessungen

Dimensioni generali e uscite / General and output dimensions / General-und Abtriebsabmessungen

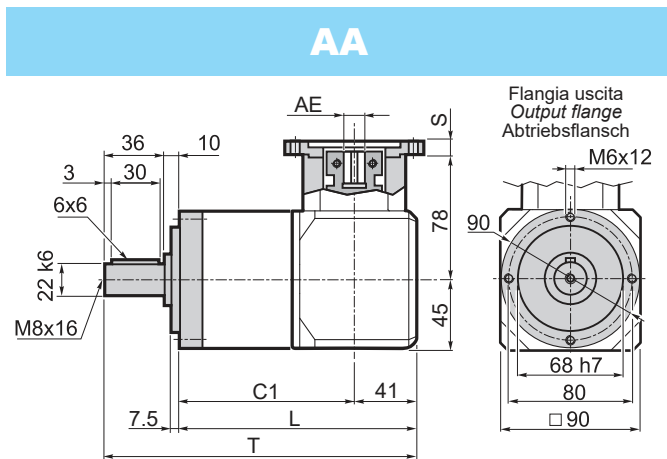

Stadi / Steps / Stufenzahl	2	3	AE=	
C1	99	128		9-9.52-11-12-12.7-14-15.87-16-19
L	140	169		
T	186	215		

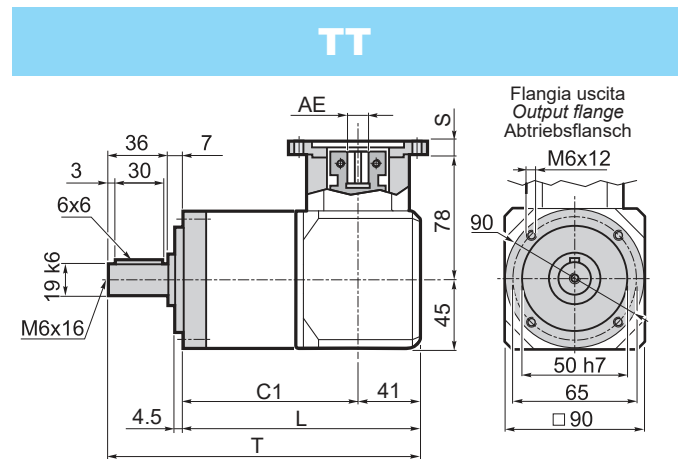

Stadi / Steps / Stufenzahl	2	3	AE=	
C1	102	131		9-9.52-11-12-12.7-14-15.87-16-19
L	143	172		
T	186	215		

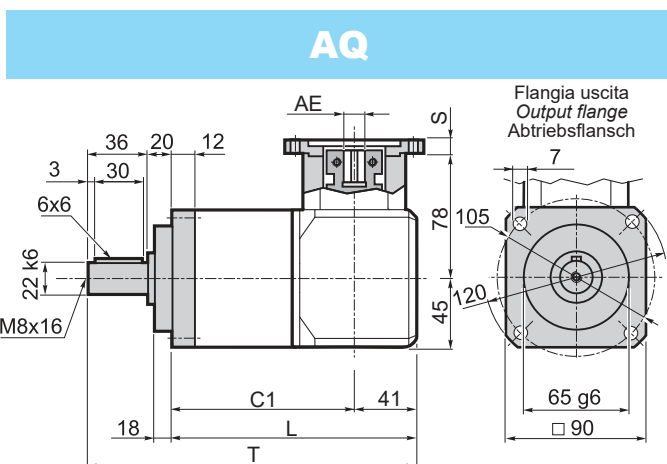

Stadi / Steps / Stufenzahl	2	3	AE=	
C1	89	118		9-9.52-11-12-12.7-14-15.87-16-19
L	130	159		
T	186	215		

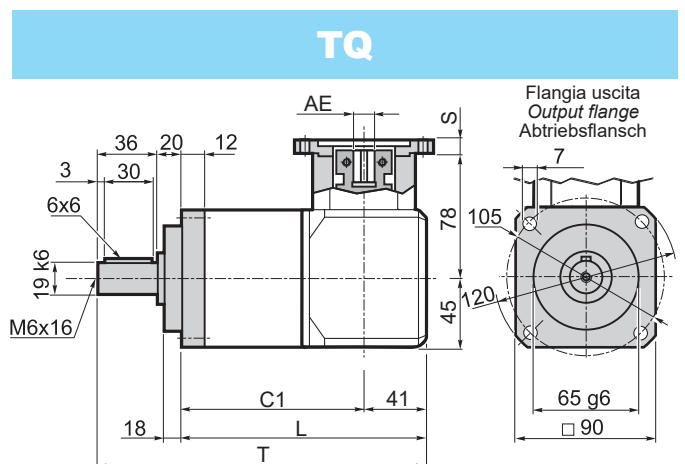

Stadi / Steps / Stufenzahl	2	3	AE=	
C1	89	118		9-9.52-11-12-12.7-14-15.87-16-19
L	130	159		
T	186	215		

Dimensioni entrate / Input dimensions / Antriebsabmessungen

Flangia entrata
Input flange
Antriebsflansch

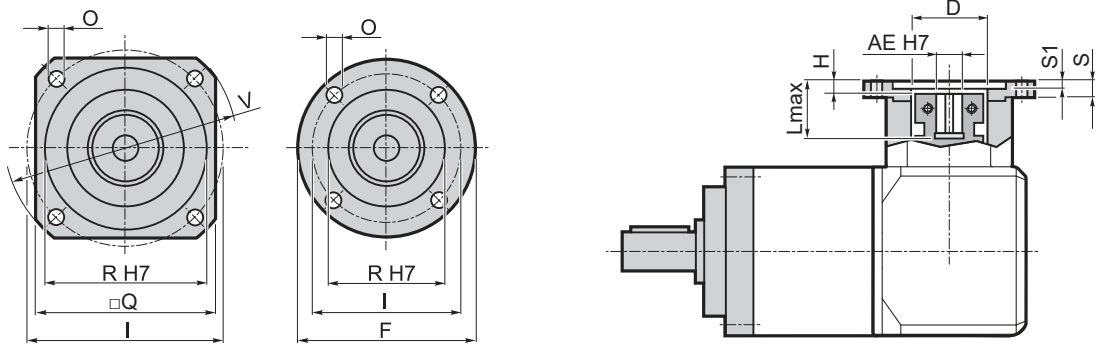

Flange entrata / Input flange / Antriebsflansch										Albero entrata / Input shaft / Antriebswelle													
										AE													
										9		9.525		11		12		12.7		14		15.87	
F	Q	V	I	R (H7)	O	S	S1	D	L max	H	L max	H	L max	H	L max	H	L max	H	L max	H	L max	H	
P01*	80	=	=	66.67	38.1	5.5	12	3	38.1	44	6.5	44	9	44	9	44	9	44	9	44	9	44	9
P02	=	106.5	140	125.72	55.52	7	11	3	45	43	5.5	43	8	43	8	43	8	43	8	43	8	43	8
P03*	=	80	90	75	60	5.5	12	3.5	45	44	6.5	44	9	44	9	44	9	44	9	44	9	44	9
P04*	105	=	=	85	70	6.5	12	3.5	45	44	6.5	44	9	44	9	44	9	44	9	44	9	44	9
P05	=	82.5	110	98.425	73.02	6.5	12	3	45	44	6.5	44	9	44	9	44	9	44	9	44	9	44	9
P06	=	90	120	100	80	6.5	13	4	45	45	7.5	45	10	45	10	45	10	45	10	45	10	45	10
P07	=	100	135	115	95	8.5	13	4.5	45	45	7.5	45	10	45	10	45	10	45	10	45	10	45	10
P08	=	116	160	130	110	9	13	4.5	45	45	7.5	45	10	45	10	45	10	45	10	45	10	45	10
P09*	80	=	=	39	26	4.5	12	4	26	44	6.5	44	9	44	9	44	9	44	9	44	9	44	9
P10*	80	=	=	65	50	5.5	12	3.5	45	44	6.5	44	9	44	9	44	9	44	9	44	9	44	9
P11	=	150	182	166	115	9	32	11	50x14	64	26.5	64	29	64	29	64	29	64	29	64	29	64	29
P12*	=	80	105	90	70	6.5	12	3.5	32	44	6.5	44	9	44	9	44	9	44	9	44	9	44	9
P14*	105	=	=	90	70	6	19	9	32	51	13.5	51	16	51	16	51	16	51	16	51	16	51	16
P15*	80	=	=	70	50	4.5	17	8	45	49	11.5	49	14	49	14	49	14	49	14	49	14	49	14
P16	=	142	190	165	130	11	13	4.5	45	45	7.5	45	10	45	10	45	10	45	10	45	10	45	10
P17*	80	=	=	63	40	5.5	12	3.5	40	44	6.5	44	9	44	9	44	9	44	9	44	9	44	9
P18	=	130	170	145	110	M8	31	7	32	63	25.5	63	28	63	28	63	28	63	28	63	28	63	28
P19*	=	80	105	90	60	6.5	12	3.5	32	44	6.5	44	9	44	9	44	9	44	9	44	9	44	9
P20*	=	80	105	85	55	5.5	12	3.5	36	44	6.5	44	9	44	9	44	9	44	9	44	9	44	9
P21	=	80	110	95	50	M6	12	3.5	45	44	6.5	44	9	44	9	44	9	44	9	44	9	44	9
P22	80	=	=	70	50	M4	12	4	45	44	6.5	44	9	44	9	44	9	44	9	44	9	44	9
P23	=	80	90	75	60	M5	12	3.5	45	44	6.5	44	9	44	9	44	9	44	9	44	9	44	9
P24	80	=	=	46	30	M4	12	4	30	44	6.5	44	9	44	9	44	9	44	9	44	9	44	9
P26	80	=	=	65	40	M5	12	3.5	40	44	6.5	44	9	44	9	44	9	44	9	44	9	44	9
P27	=	80	110	82.02	36.8	M6	14	10	36.8	46	8.5	46	11	46	11	46	11	46	11	46	11	46	11
P28	=	90	120	100	80	6.5	28	4	45	60	22.5	60	25	60	25	60	25	60	25	60	25	60	25
P29*	80	=	=	66.67	50	5.5	12	3	45	44	6.5	44	9	44	9	44	9	44	9	44	9	44	9
P30	=	115	155	130	80	9	13	4	45	45	7.5	45	10	45	10	45	10	45	10	45	10	45	10
P31*	=	80	105	56	44	M6	14	10	36.8	46	8.5	46	11	46	11	46	11	46	11	46	11	46	11
P32	=	80	105	90	70	M6	12	3.5	32	44	6.5	44	9	44	9	44	9	44	9	44	9	44	9
P33	=	130	165	145	110	9	13	4.5	45	45	7.5	45	10	45	10	45	10	45	10	45	10	45	10
P34	=	90	120	100	80	M6	19	5	45	51	13.5	51	16	51	16	51	16	51	16	51	16	51	16
P36	=	100	135	115	95	M8	25	4.5	45	57	19.5	57	22	57	22	57	22	57	22	57	22	57	22
P37	=	85	115	98.99	60	M6	12	3.5	32	44	6.5	44	9	44	9	44	9	44	9	44	9	44	9
P38	80	=	=	70	50	M5	12	4	45	44	6.5	44	9	44	9	44	9	44	9	44	9	44	9
P39	=	90	120	100	80	6.5	13	4.5	45	45	7.5	45	10	45	10	45	10	45	10	45	10	45	10
P40	=	80	90	75	60	M6	12	3.5	45	44	6.5	44	9	44	9	44	9	44	9	44	9	44	9
P42	=	110	145	125.72	55.5	M8	28	3	45	60	22.5	60	25	60	25	60	25	60	25	60	25	60	25
P44*	=	80	105	90	70	6	13	5	32	45	7.5	45	10	45	10	45	10	45	10	45	10	45	10
P46	=	100	135	115	95	8.5	17	8	45	49	11.5	49	14	49	14	49	14	49	14	49	14	49	14
P47	=	90	120	100	50	M6	12	4.5	45	44	6.5	44	9	44	9	44	9	44	9	44	9	44	9

* Per assemblare il motore è necessario smontare la flangia dal riduttore (vedere schema di montaggio 2 a pag. 67).

* Before the mounting of the motor it is necessary to remove the flange from the gearbox (see structural arrangement 2 at the top of the page 67).

* Vor dem Einbauen des Motors soll die Getriebeflange abmontiert werden (siehe Bauanleitung 2 auf Seite 67).

TEP 120																		Stadi Steps Stufenzahl		
Stadi Steps Stufenzahl	2					3												2	3	
	i	3	4	5	7	10	9	12	15	16	20	25	28	35	40	50	70			100
T _{2N}	60	80	100	140	100	150	180	180	180	180	180	180	180	180	180	170	110	n _{1nom}	2500	
T _{2A}	108	144	180	220	180	240	290	290	290	290	290	290	290	290	290	270	200	n _{1max}	4000	
T _{2S}	216	288	360	440	380	500	600	600	600	600	600	600	600	600	600	540	400	LpA	< 70	
J	Vedi pag. 54 / See page 54 / Siehe auf Seite 54																	Lh	20000	
R _t	16					14.5					16					14.5			F _{R2}	4500
R _d	0.94					0.91												F _{A2}	4000	
Kg	11.7					12.2												α _{max}	12' 15'	

F_{R2} Carico radiale nominale in uscita [N] a 100min⁻¹
 F_{A2} Carico assiale in uscita [N] a 100min⁻¹

Rated output radial load [N] at 100min⁻¹
 Output axial load [N] at 100min⁻¹

Nenn-Radiallast an der Abtriebswelle bei 100min⁻¹
 Axiallast an der Abtriebswelle bei 100min⁻¹

3.10 Dimensioni

3.10 Dimensions

3.10 Abmessungen

Dimensioni generali e uscite / General and output dimensions / General-und Abtriebsabmessungen

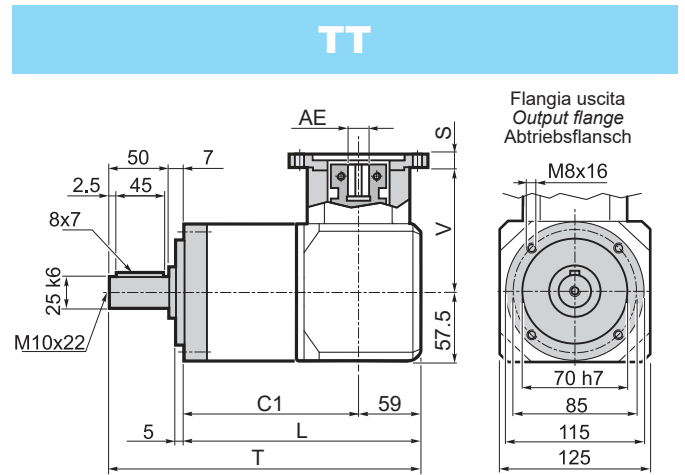
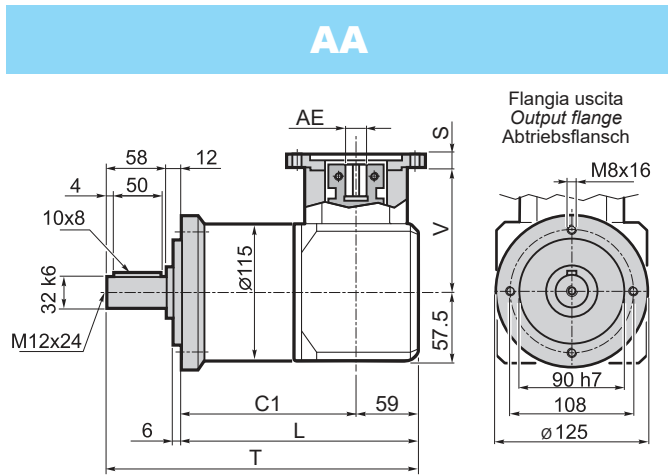

Stadi / Steps / Stufenzahl	2	3	AE= 14-15.87-16-19 22-24-25-28
C1	134.5	167.1	
L	193.5	226.1	
T	263.5	296.1	
V	89	AE= 14-15.87-16-19	
	108	AE= 22-24-25-28	

Stadi / Steps / Stufenzahl	2	3	AE= 14-15.87-16-19 22-24-25-28
C1	139.5	172.1	
L	198.5	231.1	
T	255.5	288.1	
V	89	AE= 14-15.87-16-19	
	108	AE= 22-24-25-28	

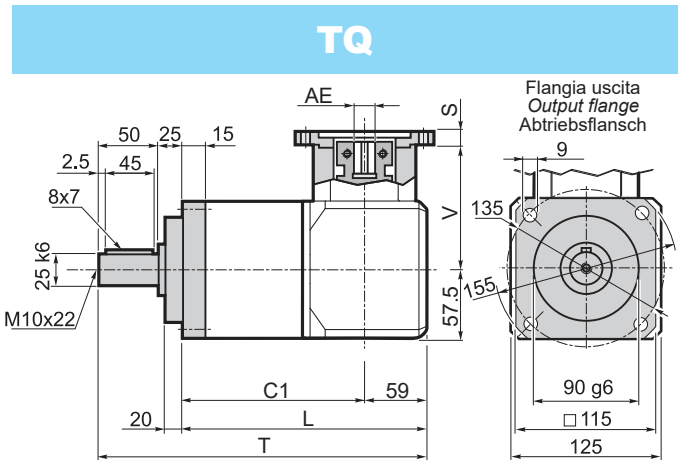
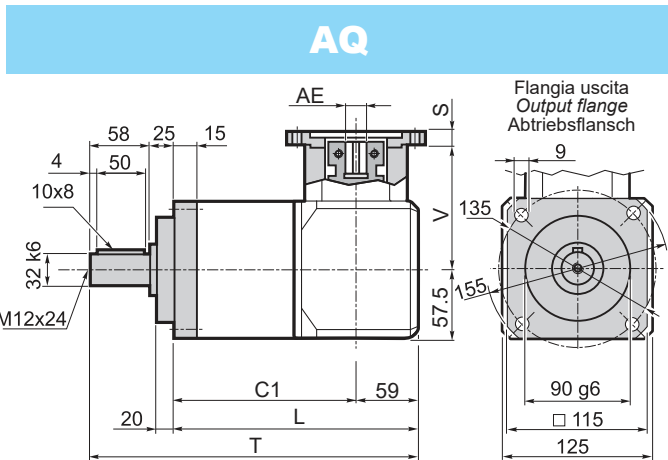

Stadi / Steps / Stufenzahl	2	3	AE= 14-15.87-16-19 22-24-25-28
C1	121.5	154.1	
L	180.5	213.1	
T	263.5	296.1	
V	89	AE= 14-15.87-16-19	
	108	AE= 22-24-25-28	

Stadi / Steps / Stufenzahl	2	3	AE= 14-15.87-16-19 22-24-25-28
C1	121.5	154.1	
L	180.5	213.1	
T	263.5	296.1	
V	89	AE= 14-15.87-16-19	
	108	AE= 22-24-25-28	

Dimensioni entrate / Input dimensions / Antriebsabmessungen

Flangia entrata
Input flange
Antriebsflansch

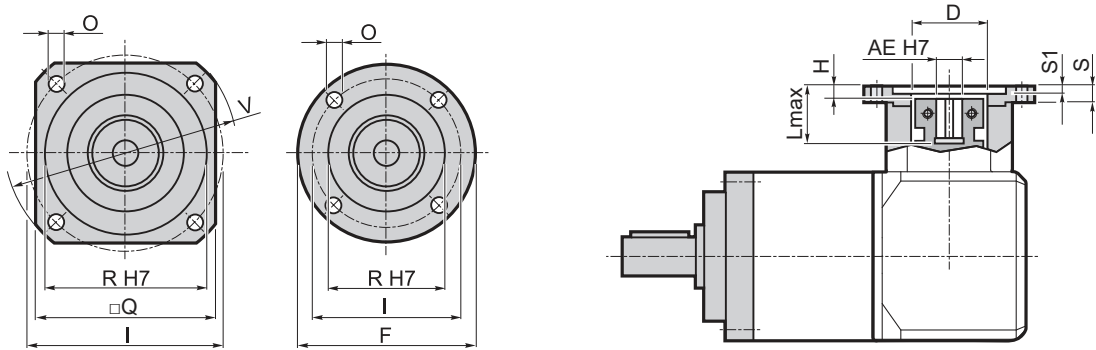

Flange entrata / Input flange / Antriebsflansch										Albero entrata / Input shaft / Antriebswelle															
										AE															
										14		15.87		16		19		22		24		25		28	
F	Q	V	I	R (H7)	O	S	S1	D	L max	H	L max	H	L max	H	L max	H	L max	H	L max	H	L max	H	L max	H	
P01*	=	115	140	125.72	55.52	6.5	13	3	55.52	43	6	43	6	43	6	43	6	62	6	62	6	62	6	62	6
P02*	115	=	=	75	60	5.5	13	3.5	60	43	6	43	6	43	6	43	6	62	6	62	6	62	6	62	6
P03*	115	=	=	85	70	6.5	13	3.5	60	43	6	43	6	43	6	43	6	62	6	62	6	62	6	62	6
P04*	115	=	=	98.42	73.02	6.5	13	3	60	43	6	43	6	43	6	43	6	62	6	62	6	62	6	62	6
P05*	120	=	=	100	80	6.5	13	4	60	43	6	43	6	43	6	43	6	62	6	62	6	62	6	62	6
P06*	=	115	140	115	95	9	13	4.5	60	43	6	43	6	43	6	43	6	62	6	62	6	62	6	62	6
P07	=	115	160	130	110	8.5	13	4.5	60	43	6	43	6	43	6	43	6	62	6	62	6	62	6	62	6
P08	=	142	190	165	130	11	13	4.5	60	43	6	43	6	43	6	43	6	62	6	62	6	62	6	62	6
P09	=	192	250	215	180	13	14	4.5	60	44	7	44	7	44	7	44	7	63	7	63	7	63	7	63	7
P10*	115	=	=	65	50	6.5	13	3.5	50	43	6	43	6	43	6	43	6	62	6	62	6	62	6	62	6
P11	=	130	170	145	110	M 8	31	7	60	61	24	61	24	61	24	61	24	80	24	80	24	80	24	80	24
P12	=	130	170	145	110	M 8	17	7	60	47	10	47	10	47	10	47	10	66	10	66	10	66	10	66	10
P13	=	115	160	130	110	M 8	13	4.5	60	43	6	43	6	43	6	43	6	62	6	62	6	62	6	62	6
P14*	115	=	=	70	50	6.5	13	3.5	50	43	6	43	6	43	6	43	6	62	6	62	6	62	6	62	6
P15	115	=	=	90	70	M5	11	3.5	60	41	4	41	4	41	4	41	4	60	4	60	4	60	4	60	4
P17*	115	=	=	90	70	6.5	13	3.5	60	43	6	43	6	43	6	43	6	62	6	62	6	62	6	62	6
P18	=	115	155	130	95	8.5	13	4.5	60	43	6	43	6	43	6	43	6	62	6	62	6	62	6	62	6
P19*	115	=	=	95	50	6.5	13	3.5	50	43	6	43	6	43	6	43	6	62	6	62	6	62	6	62	6
P20	115	=	=	99	60	M6	13	4	60	43	6	43	6	43	6	43	6	62	6	62	6	62	6	62	6
P21*	130	=	=	106	82.5	12.5	26.5	15	60	56.5	19.5	56.5	19.5	56.5	19.5	56.5	19.5	75.5	19.5	75.5	19.5	75.5	19.5	75.5	19.5
P22	=	144	190	165	110	11	15	4.5	60	45	8	45	8	45	8	45	8	64	8	64	8	64	8	64	8
P23*	115	=	=	63	40	5.5	11	3.5	40	41	4	41	4	41	4	41	4	60	4	60	4	60	4	60	4
P24	120	=	=	100	80	M6	18	7	60	48	11	48	11	48	11	48	11	67	11	67	11	67	11	67	11
P25	=	115	155	115	95	M8	27	4.5	60	57	20	57	20	57	20	57	20	76	20	76	20	76	20	76	20
P26	=	115	155	131.95	55.52	M8	27	4.5	60	57	20	57	20	57	20	57	20	76	20	76	20	76	20	76	20
P27	170	=	=	148	114	8.5	13	4	60	43	6	43	6	43	6	43	6	62	6	62	6	62	6	62	6
P28	=	115	140	115	95	M8	16	6	60	46	9	46	9	46	9	46	9	65	9	65	9	65	9	65	9
P29	133,5	=	=	121.5	60	M6	13	13	60	43	6	43	6	43	6	43	6	62	6	62	6	62	6	62	6

* Per assemblare il motore è necessario smontare la flangia dal riduttore (vedere schema di montaggio 2 a pag. 67).

* Before the mounting of the motor it is necessary to remove the flange from the gearbox (see structural arrangement 2 at the top of the page 67).

* Vor dem Einbauen des Motors soll die Getriebeflangens abmontiert werden (siehe Bauanleitung 2 auf Seite 67).

TEP 155																		Stadi Steps Stufenzahl			
Stadi Steps Stufenzahl	2					3												2	3		
	i	3	4	5	7	10	9	12	15	16	20	25	28	35	40	50	70			100	
T _{2N}	170	230	290	300	220	320	400	430	430	430	430	430	430	430	430	430	350	250	n _{1nom}	2500	
T _{2A}	270	360	450	480	400	480	600	650	650	650	650	650	650	650	650	650	560	460	n _{1max}	4000	
T _{2S}	540	720	900	1000	850	1000	1250	1300	1300	1300	1300	1300	1300	1300	1300	1120	920	LpA	< 70		
J	Vedi pag. 55 / See page 55 / Siehe auf Seite 55																	Lh	20000		
R _t	34.5					31		34.5										31		F _{R2} (AA)	6500
																				F _{R2} (TT)	5300
R _d	0.94					0.91														F _{A2} (AA)	3250
																				F _{A2} (TT)	2650
Kg	17.5					22														α _{max}	12' 15'

F_{R2} Carico radiale nominale in uscita [N] a 100min⁻¹
 F_{A2} Carico assiale in uscita [N] a 100min⁻¹

Rated output radial load [N] at 100min⁻¹
 Output axial load [N] at 100min⁻¹

Nenn-Radiallast an der Abtriebswelle bei 100min⁻¹
 Axiallast an der Abtriebswelle bei 100min⁻¹

3.10 Dimensioni

3.10 Dimensions

3.10 Abmessungen

Dimensioni generali e uscite / General and output dimensions / General-und Abtriebsabmessungen

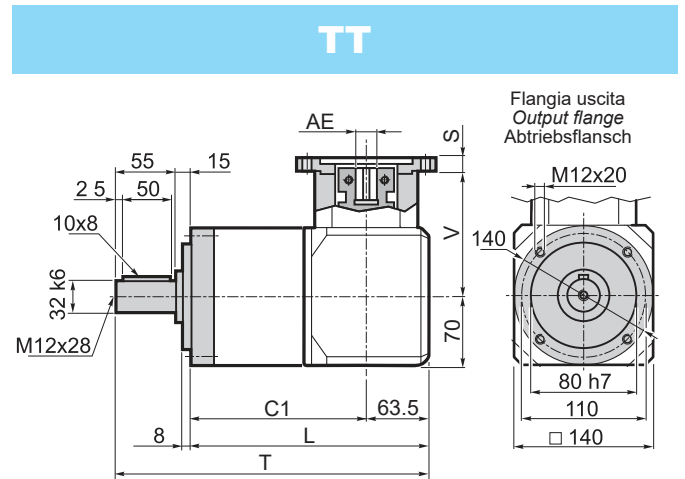
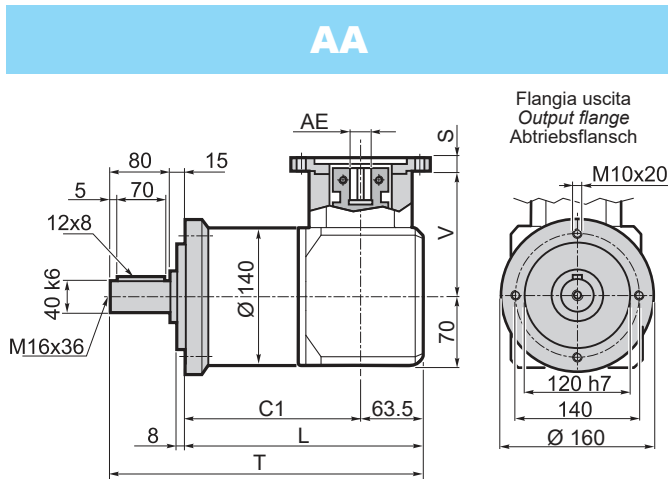

Stadi / Steps / Stufenzahl	2	3	AE= 15.87-16-19-22-24 28-32-35-38
C1	175	216.5	
L	238.5	280	
T	333.5	375	
V	105	AE= 15.87-16-19-22-24	
	130	AE= 28-32-35-38	

Stadi / Steps / Stufenzahl	2	3	AE= 15.87-16-19-22-24 28-32-35-38
C1	175	216.5	
L	238.5	280	
T	308.5	350	
V	105	AE= 15.87-16-19-22-24	
	130	AE= 28-32-35-38	

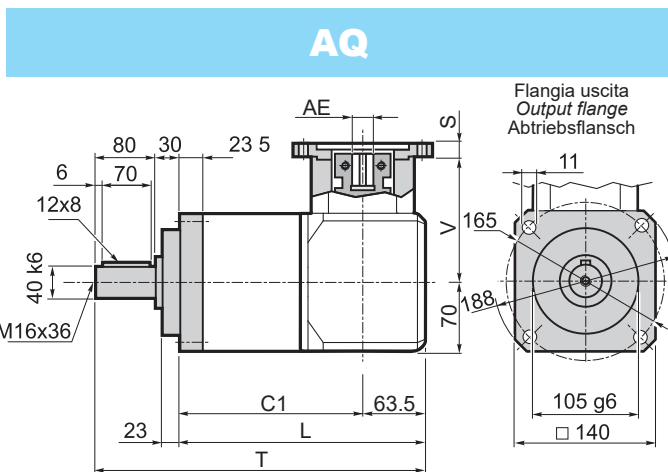

Stadi / Steps / Stufenzahl	2	3	AE= 15.87-16-19-22-24 28-32-35-38
C1	160	201.5	
L	223.5	265	
T	333.5	375	
V	105	AE= 15.87-16-19-22-24	
	130	AE= 28-32-35-38	

Dimensioni entrate / Input dimensions / Antriebsabmessungen

Flangia entrata
Input flange
Antriebsflansch

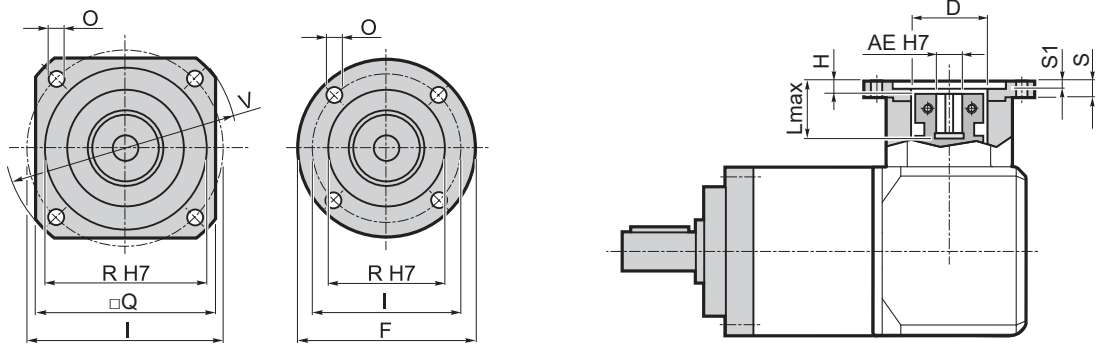

Flange entrata / Input flange / Antriebsflansch										Albero entrata / Input shaft / Antriebswelle															
										AE															
										15.87		16		19		22		24		28		32		35	
F	Q	V	I	R (H7)	O	S	S1	D	L _{max}	H	L _{max}	H	L _{max}	H	L _{max}	H	L _{max}	H	L _{max}	H	L _{max}	H			
P01*	140	=	=	125.72	55.52	6.5	15	4	55.52	57.8	6.8	57.8	6.8	57.8	6.8	57.8	6.8	57.8	6.8	82.8	7.3	82.8	7.3	82.8	7.3
P02*	140	=	=	100	80	6.5	15	4	70	57.8	6.8	57.8	6.8	57.8	6.8	57.8	6.8	57.8	6.8	82.8	7.3	82.8	7.3	82.8	7.3
P03*	140	=	=	115	95	8.5	15	4.5	70	57.8	6.8	57.8	6.8	57.8	6.8	57.8	6.8	57.8	6.8	82.8	7.3	82.8	7.3	82.8	7.3
P04*	=	140	160	130	110	8.5	15	4.5	70	57.8	6.8	57.8	6.8	57.8	6.8	57.8	6.8	57.8	6.8	82.8	7.3	82.8	7.3	82.8	7.3
P05	=	142	190	165	130	11	15	4.5	70	57.8	6.8	57.8	6.8	57.8	6.8	57.8	6.8	57.8	6.8	82.8	7.3	82.8	7.3	82.8	7.3
P06	=	190	250	215	180	13	15	4.5	70	57.8	6.8	57.8	6.8	57.8	6.8	57.8	6.8	57.8	6.8	82.8	7.3	82.8	7.3	82.8	7.3
P07	=	250	300	265	230	13	15	4.5	70	57.8	6.8	57.8	6.8	57.8	6.8	57.8	6.8	57.8	6.8	82.8	7.3	82.8	7.3	82.8	7.3
P08	=	130	165	145	110	M 8	18	7	70	60.8	9.8	60.8	9.8	60.8	9.8	60.8	9.8	60.8	9.8	85.8	10.3	85.8	10.3	85.8	10.3
P09	=	180	230	200	114.3	13.5	22	11	70	64.8	13.8	64.8	13.8	64.8	13.8	64.8	13.8	64.8	13.8	89.8	14.3	89.8	14.3	89.8	14.3
P10	=	115	150	130	95	M 8	15	4.5	70	57.8	6.8	57.8	6.8	57.8	6.8	57.8	6.8	57.8	6.8	82.8	7.3	82.8	7.3	82.8	7.3
P11	=	180	230	198	155	13.5	22	7	120x11	64.8	13.8	64.8	13.8	64.8	13.8	64.8	13.8	64.8	13.8	89.8	14.3	89.8	14.3	89.8	14.3
P12	=	220	270	235	200	13.5	15	5	70	57.8	6.8	57.8	6.8	57.8	6.8	57.8	6.8	57.8	6.8	82.8	7.3	82.8	7.3	82.8	7.3
P13	=	190	250	215	130	13	15	4.5	70	57.8	6.8	57.8	6.8	57.8	6.8	57.8	6.8	57.8	6.8	82.8	7.3	82.8	7.3	82.8	7.3
P14	=	142	190	165	110	11	15	4.5	70	57.8	6.8	57.8	6.8	57.8	6.8	57.8	6.8	57.8	6.8	82.8	7.3	82.8	7.3	82.8	7.3
P15*	150	=	=	90	70	6.5	15	4	70	57.8	6.8	57.8	6.8	57.8	6.8	57.8	6.8	57.8	6.8	82.8	7.3	82.8	7.3	82.8	7.3
P16	=	146	200	177.8	114.3	10.5	15	3.5	70	57.8	6.8	57.8	6.8	57.8	6.8	57.8	6.8	57.8	6.8	82.8	7.3	82.8	7.3	82.8	7.3
P17	=	130	165	145	110	M 8	28	7	70	70.8	19.8	70.8	19.8	70.8	19.8	70.8	19.8	70.8	19.8	95.8	20.3	95.8	20.3	95.8	20.3
P18	140	=	=	100	80	M 6	22	6	70	64.8	13.8	64.8	13.8	64.8	13.8	64.8	13.8	64.8	13.8	89.8	14.3	89.8	14.3	89.8	14.3
P19	=	130	165	145	110	M 8	27	7	70	69.8	18.8	69.8	18.8	69.8	18.8	69.8	18.8	69.8	18.8	94.8	19.3	94.8	19.3	94.8	19.3

1

Schema di montaggio / Assembly drawing / Bauanleitung 1

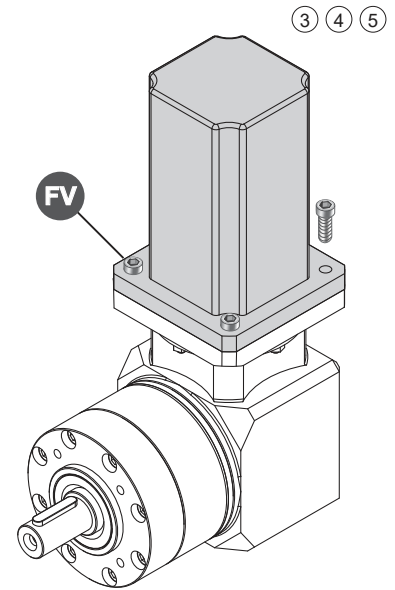
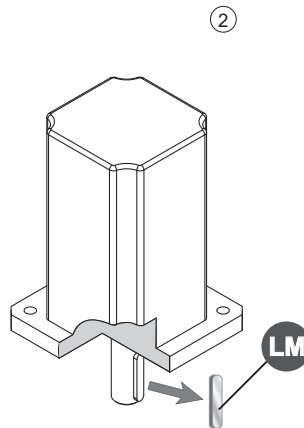
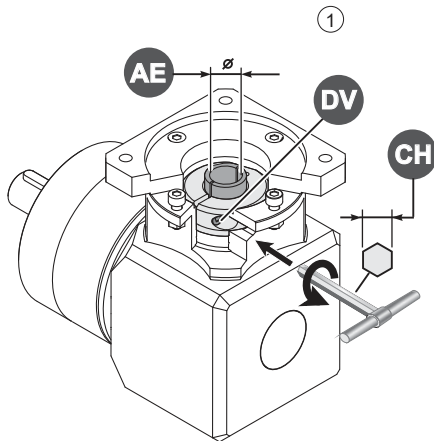

- 1 - Allentare la vite di serraggio del morsetto (DV)
- 2 - Estrarre la linguetta (LM) dall'albero motore
- 3 - Pulire le superfici di contatto delle flange motore e riduttore
- 4 - Calettare il motore sul riduttore evitando urti
- 5 - Stringere le viti di assemblaggio (FV) in modo alternato
- 6 - Assicurarsi che il morsetto venga serrato posizionandolo verso il motore e rispettando la fasatura dei tagli
- 7 - Serrare la vite (o le viti) del morsetto (DV) alla coppia (CS) indicata in tabella

- 1 - Unloose the fastening screw (or screws) of the clamp (DV)
- 2 - Remove the key (LM) from motor shaft
- 3 - Clean the contact surfaces of motor flange/gearbox flange
- 4 - Avoid impacts while fitting motor to gearbox
- 5 - Tighten the assembling screws (FV) alternately
- 6 - Fix the clamp towards the motor and tighten it in compliance with the cuts timing
- 7 - Tighten the clamp screw, or screws (DV) according to the torque (CS) reported in the table

- 1 - die Befestigungsschraube der Klammer (DV) lockern
- 2 - die Feder (LM) aus Motorwelle ziehen
- 3 - die Motorflansch / Getriebeflansch Kontaktfläche reinigen
- 4 - Motor und Getriebe ohne Stöße verkeilen
- 5 - die Befestigungsschrauben (FV) abwechselnd anziehen
- 6 - Die Klammer soll zum Motor angezogen. Dabei soll die Zuendeinstellung der Schnitte geachtet
- 7 - die Schraube (oder Schrauben) der Klammer (DV) zu dem in der Tabelle angegebenen Anzugsmoment anziehen

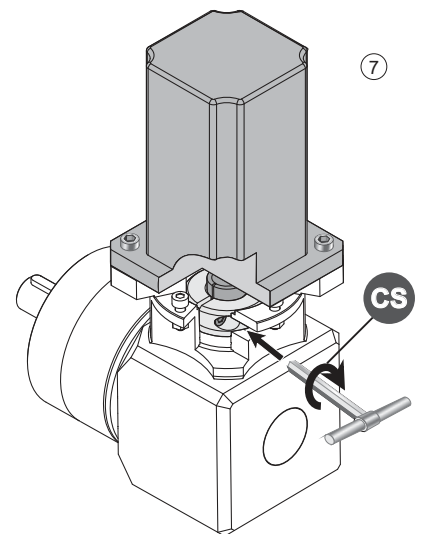
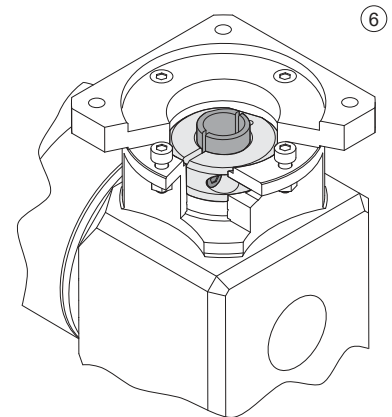

TEP 55	AE	6	6.35	7	8	9	9.52	11				
	DV	M4 x 16										
	NV	1										
	CH	3										
	CS [Nm]	4.8										
TEP 75	AE	6	6.35	7	8	9	9.52	11	12	12.7	14	
	DV	M4 x 16										
	NV	1										
	CH	3										
	CS [Nm]	4.8										
TEP 90	AE	9	9.52	11	12	12.7	14	15.87	16	19		
	DV	M4 x 16								M5 x 20		
	NV	1								1		
	CH	3								4		
	CS [Nm]	4.8								9.4		
TEP 120	AE	12.7	14	15.87	16	19	22	24	25	28		
	DV	M4 x 16			M5 x 20			M6 x 20				
	NV	1			1			2				
	CH	3			4			5				
	CS [Nm]	4.8			9.4			16.2				
TEP 155	AE	15.87	16	19	22	24	28	32	35	38		
	DV	M6 x 20			M6 x 20			M6 x 20				
	NV	1			2			3				
	CH	5			5			5				
	CS [Nm]	16.2			16.2			16.2				

Tutte le viti hanno classe di resistenza 12.9
 All screws supplied according to strenght class 12.9
 Alle Schrauben nach Festigkeitsklasse 12.9 geliefert

AE= Albero entrata / Input shaft / Antriebswelle
 DV= Diametro vite / Screw diameter / Schraubendurchmesser

NV= Numero viti / Number of screw / Schraubenanzahl
 CS= Coppia di serraggio / Setting torque / Spannungsmoment

3.11 Istruzioni per il montaggio del motore

3.11 Instructions for assembly of motor

3.11 Anleitung für motormontage

2

Schema di montaggio / Assembly drawing / Bauanleitung 2

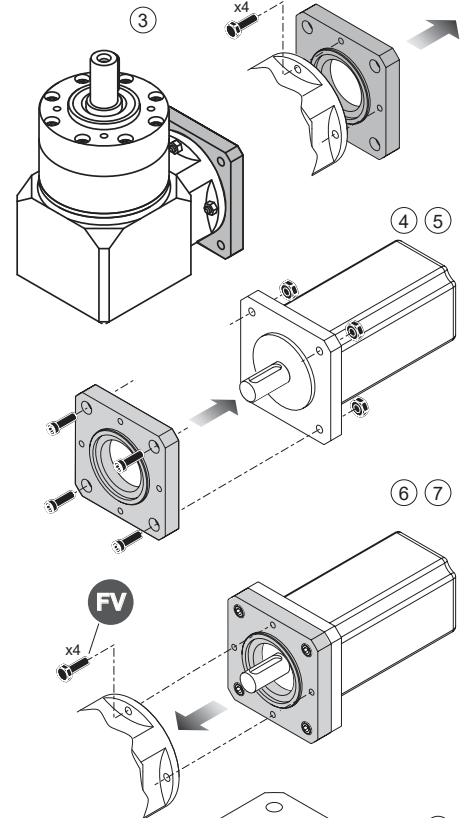
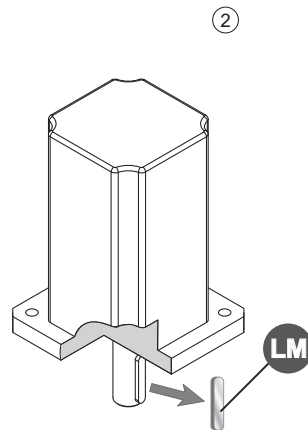
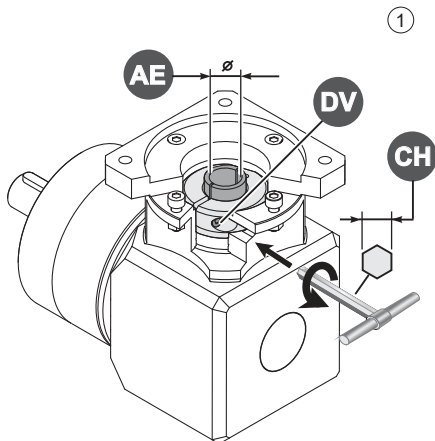

- 1 - Allentare la vite di serraggio del morsetto (DV)
- 2 - Estrarre la linguetta (LM) dall'albero motore
- 3 - Smontare la flangia dal riduttore
- 4 - Pulire le superfici di contatto delle flange motore e riduttore
- 5 - Fissare la flangia sul motore
- 6 - Calettare il motore sul riduttore evitando urti
- 7 - Stringere le viti di assemblaggio (FV) in modo alternato
- 8 - Assicurarsi che il morsetto venga serrato posizionandolo verso il motore e rispettando la fasatura dei tagli
- 9 - Serrare la vite (o le viti) del morsetto (DV) alla coppia (CS) indicata in tabella

- 1 - Unloose the fastening screw (or screws) of the clamp (DV)
- 2 - Remove the key (LM) from motor shaft
- 3 - Remove the flange from the gearbox
- 4 - Clean the contact surfaces of motor flange/gearbox flange
- 5 - Fix the flange on the motor
- 6 - Avoid impacts while fitting motor to gearbox
- 7 - Tighten the assembling screws (FV) alternatively
- 8 - Fix the clamp towards the motor and tighten it in compliance with the cuts timing
- 9 - Tighten the clamp screw, or screws (DV) according to the torque (CS) reported in the table

- 1 - die Befestigungsschraube der Klammer (DV) lockern
- 2 - die Feder (LM) aus Motorwelle ziehen
- 3 - die Flansch von Getriebe abmontieren
- 4 - die Motorflansch / Getriebe-Flansch Kontaktfläche reinigen
- 5 - die Flansch an Motor befestigen
- 6 - Motor und Getriebe ohne Stöße verkeilen
- 7 - die Befestigungsschrauben (FV) abwechselnd anziehen
- 8 - Die Klammer soll zum Motor angezogen. Dabei soll die Zuendeinstellung de Schnitte geachtet
- 9 - die Schraube (oder Schrauben) der Klammer (DV) zu dem in der Tabelle angegebenen Anzugsmoment anziehen

TEP 55	AE	6	6.35	7	8	9	9.52	11				
	DV	M4 x 16										
	NV	1										
	CH	3										
	CS [Nm]	4.8										
TEP 75	AE	6	6.35	7	8	9	9.52	11	12	12.7	14	
	DV	M4 x 16										
	NV	1										
	CH	3										
	CS [Nm]	4.8										
TEP 90	AE	9	9.52	11	12	12.7	14	15.87	16	19		
	DV	M4 x 16							M5 x 20			
	NV	1							1			
	CH	3							4			
	CS [Nm]	4.8							9.4			
TEP 120	AE	12.7	14	15.87	16	19	22	24	25	28		
	DV	M4 x 16			M5 x 20			M6 x 20				
	NV	1			1			2				
	CH	3			4			5				
	CS [Nm]	4.8			9.4			16.2				
TEP 155	AE	15.87	16	19	22	24	28	32	35	38		
	DV	M6 x 20			M6 x 20			M6 x 20				
	NV	1			2			3				
	CH	5			5			5				
	CS [Nm]	16.2			16.2			16.2				

Tutte le viti hanno classe di resistenza 12.9

All screws supplied according to strenght class 12.9

Alle Schrauben nach Festigkeitsklasse 12.9 geliefert

AE= Albero entrata / Input shaft / Antriebswelle

DV= Diametro vite / Screw diameter / Schraubendurchmesser

NV= Numero viti / Number of screw / Schraubenanzahl

CS= Coppia di serraggio / Setting torque / Spannungsmoment

4.1 Esempi di applicazioni

4.1 Examples of applications

4.1 Anwendungsbeispiele

Carrello scorrevole

Sliding carriage

Laufwagen

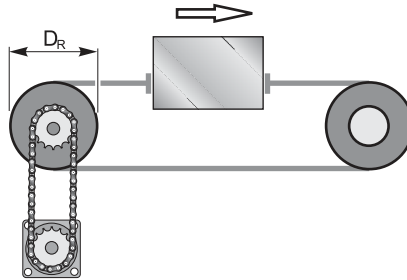

L'applicazione prevede la movimentazione lineare di una tavola tramite una catena (rapporto di riduzione della trasmissione: $i=1$)
 La massa del carrello è di $m=200$ kg e $D_R=0.1$ m.
 Il carrello deve essere accelerato in $t_a=0.2$ s ad una velocità massima $v_2=0.6$ m/s.
 Il rapporto di riduzione del riduttore è $i=20$.
 La forza resistente che si oppone allo spostamento è pari a $F=500$ N (data dal prodotto della forza per il coefficiente di attrito).

*The application requires the linear motion of a table by means of a chain (reduction ratio of the transmission: $i=1$).
 The carriage mass is $m=200$ Kg and $D_R=0.1$ m.
 The carriage has to be accelerated in $t_a=0.2$ s to a maximum speed $v_2=0.6$ m/s.
 The reduction ratio of the gearbox is $i=20$.
 The resisting force acting against the motion is $F=500$ N (product of the force by the coefficient of friction).*

Die Applikation sieht die Linearbewegung einer Scheibe durch eine Kette vor. (Übersetzungsverhältnis: $i=1$)
 Die Masse der Wagen ist $m=200$ Kg und $D_R=0.1$ m. Der Wagen soll in $t_a=0.2$ s bis Höchstgeschwindigkeit $v_2=0.6$ m/s beschleunigt werden.
 Das Übersetzungsverhältnis des Getriebes ist $i=20$.
 Die Widerstandskraft, die gegen die Bewegung wirkt, ist $F=500$ N (Produkt von Kraft mal Reibungskoeffizient)

- Determinazione della coppia resistente T_{RES}

$$T_{RES} = F \cdot D_R / 2 = 500 \cdot 0.1 / 2 = 25 \text{ Nm}$$

- Calculation of resisting torque T_{RES}

$$T_{RES} = F \cdot D_R / 2 = 500 \cdot 0.1 / 2 = 25 \text{ Nm}$$

- Berechnung von Widerstandsdrehmoment

$$T_{RES} = F \cdot D_R / 2 = 500 \cdot 0.1 / 2 = 25 \text{ Nm}$$

- Determinazione della coppia resistente T_{IN} dovuta all'inerzia

$$T_{IN} = F_i \cdot D_R / 2 \text{ (Nm)}$$

- Calculation of resisting torque of inertia T_{IN}

$$T_{IN} = F_i \cdot D_R / 2 \text{ (Nm)}$$

- Berechnung von Trägheitsdrehmoment T_{IN}

$$T_{IN} = F_i \cdot D_R / 2 \text{ (Nm)}$$

Dove F_i è la forza di inerzia, la quale, nel caso di traslazione, vale:

$$F_i = m \cdot a \quad (\text{N})$$

F_i is the inertial force which, in case of translation, is:

$$F_i = m \cdot a \quad (\text{N})$$

F_i ist die Trägheit, die im Falle von Translation wie folgt ist :

$$F_i = m \cdot a \quad (\text{N})$$

In questo caso, l'accelerazione risulta:

$$a = (v_2 - v_0) / t_a \quad (\text{m/s}^2)$$

con v_2 = velocità finale (m/s)
 v_0 = velocità iniziale (m/s)
 t_a = tempo di accelerazione (s)

quindi:

$$a = (0.6 - 0) / 0.2 = 3 \text{ m/s}^2$$

$$F_i = 200 \cdot 3 = 600 \text{ N}$$

$$T_{IN} = 600 \cdot 0.1 / 2 = 30 \text{ Nm}$$

In this case, acceleration is:

$$a = (v_2 - v_0) / t_a \quad (\text{m/s}^2)$$

v_2 = final speed
 v_0 = initial speed
 t_a = acceleration time (s)

Therefore:

$$a = (0.6 - 0) / 0.2 = 3 \text{ m/s}^2$$

$$F_i = 200 \cdot 3 = 600 \text{ N}$$

$$T_{IN} = 600 \cdot 0.1 / 2 = 30 \text{ Nm}$$

In diesem Fall ist die Beschleunigung wie folgt:

$$a = (v_2 - v_0) / t_a \quad (\text{m/s}^2)$$

Mit v_2 = Endgeschwindigkeit
 v_0 = Startgeschwindigkeit
 t_a = Beschleunigungszeit(s)

Folglich:

$$a = (0.6 - 0) / 0.2 = 3 \text{ m/s}^2$$

$$F_i = 200 \cdot 3 = 600 \text{ N}$$

$$T_{IN} = 600 \cdot 0.1 / 2 = 30 \text{ Nm}$$

Pertanto, la coppia da prendere in considerazione, per dimensionare correttamente l'applicazione, vale:

$$T_2 = T_{RES} + T_{IN} = 25 + 30 = 55 \text{ Nm}$$

As a result, for the purpose of a correct dimensioning of the application, the following torque has to be taken into consideration:

$$T_2 = T_{RES} + T_{IN} = 25 + 30 = 55 \text{ Nm}$$

Damit die Dimensionierung der Applikation korrekt ist, ist das folgendes Drehmoment zu betrachten:

$$T_2 = T_{RES} + T_{IN} = 25 + 30 = 55 \text{ Nm}$$

In funzione di questo risultato si dovrà individuare un adeguato motore (in prima approssimazione: $T_{MOT} = (T_2 / i) \cdot R_d$), tale cioè da garantire una coppia motrice sufficiente a vincere gli attriti e le inerzie presenti. Successivamente, in funzione delle caratteristiche del motore scelto e delle rimanenti specifiche dell'applicazione (ciclo di lavoro, numero di cicli all'ora ecc.) si procede selezionando opportunamente il riduttore (v. selezione del riduttore).

This value has to be taken into account when selecting the motor (approx. $T_{MOT} = (T_2 / i) \cdot R_d$). The motor torque should be high enough as to overcome friction and inertia forces. Subsequently, it is possible to proceed with the selection of the gearbox on the basis of motor specifications and features of application (operation cycle, no. cycles per hour, etc.) (see selection of the gearbox).

Von diesen Wert hängt die Wahl des Motors (annähernd : $T_{MOT} = (t_2 / i) \cdot R_d$) ab. Das Antriebsdrehmoment muss ausreichend hoch sein, um Reibungs- und Trägheitskräfte überwinden zu können. Schließlich wird das Getriebe abhängig von Applikation (Arbeitszyklus, Zyklen pro Stunde, u.s.w.) und Motoreigenschaften gewählt. (Siehe Wahl des Getriebes).

Tavola rotante

Revolving table

Drehscheibe

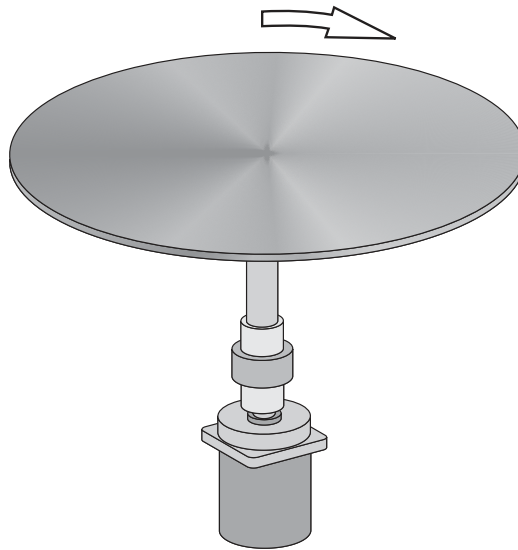

L'applicazione prevede la messa in rotazione di una tavola cilindrica di massa pari a $m=20\text{kg}$ e raggio $r=0.5\text{m}$.

Tale tavola deve essere accelerata da $n_0 = 0 \text{ min}^{-1}$ a $n_1= 300 \text{ rpm}$ in $t_a=0.3 \text{ s}$.

Il rapporto di riduzione del riduttore è $i=20$.

Si suppone che la coppia resistente per mantenere in rotazione uniforme la tavola sia trascurabile rispetto alla coppia legata all'inerzia dell'applicazione.

The application requires the rotation of a cylindrical table with mass $m=20 \text{ Kg}$ and radius $r=0.5\text{m}$.

The table has to be accelerated from $n_0=0 \text{ rpm}$ to $n_1=300 \text{ min}^{-1}$ in $t_a=0.3\text{s}$.

The reduction ratio of the gearbox is $i=20$.

The resisting torque, which enables uniform rotation of the table, is assumed to be negligible compared to the torque caused by the inertia of the application.

Die Applikation sieht die Drehung einer zylindrischen Scheibe vor, deren Masse $m=20\text{Kg}$ ist und deren Halbmesser $r=0.3 \text{ s}$ ist.

Solche Scheibe soll von $n_0 = 0 \text{ U/Min}$ bis $n_1=300 \text{ min}^{-1}$ in $t_a=0.3\text{s}$ beschleunigt werden.

Das Übersetzungsverhältnis des Getriebes ist $i=20$.

Es wird angenommen, dass das zur gleichmäßigen Drehung der Scheibe dienenden Widerstandsdrehmoment unbeträchtlich im Vergleich zum Trägheitsmoment ist.

Quindi, in questo caso:

$$T_2 = T_{IN} = J \cdot a_a \text{ (Nm)}$$

Dove $J \text{ (kgm}^2\text{)}$ è il momento d'inerzia di massa della tavola rotante, ed $a_a \text{ (rad/s}^2\text{)}$ è la accelerazione angolare.

$$J = (m \cdot r^2) / 2 = (20 \cdot 0.5^2) / 2 = 2.5 \text{ kgm}^2$$

$$a_a = \frac{\omega_1 - \omega_0}{t_a} \text{ (rad/s}^2\text{)}$$

$$\omega_1 = (2 \cdot \pi \cdot n_1) / 60 = (2 \cdot \pi \cdot 300) / 60 = 31.4 \text{ rad/s}$$

Quindi:

$$a_a = \frac{31.4 - 0}{0.3} = 104.6 \text{ (rad/s}^2\text{)}$$

Infine:

$$T_2 = T_{IN} = 2.5 \cdot 104.6 = 261 \text{ Nm}$$

In funzione di questo risultato si dovrà individuare un adeguato motore (in prima approssimazione: $T_{MOT} = (T_2 / i) \cdot R_d$), tale cioè da garantire una coppia motrice sufficiente a vincere gli attriti e le inerzie presenti. Successivamente, in funzione delle caratteristiche del motore scelto e delle rimanenti specifiche dell'applicazione (ciclo di lavoro, numero di cicli all'ora ecc.) si procede selezionando opportunamente il riduttore (v. selezione del riduttore).

Therefore, in this case:

$$T_2 = T_{IN} = J \cdot a_a \text{ (Nm)}$$

$J \text{ (kgm}^2\text{)}$ is the moment of inertia of the mass of the revolving table and $a_a \text{ (rad/s}^2\text{)}$ is the angular acceleration.

$$J = (m \cdot r^2) / 2 = (20 \cdot 0.5^2) / 2 = 2.5 \text{ kgm}^2$$

$$a_a = \frac{\omega_1 - \omega_0}{t_a} \text{ (rad/s}^2\text{)}$$

$$\omega_1 = (2 \cdot \pi \cdot n_1) / 60 = (2 \cdot \pi \cdot 300) / 60 = 31.4 \text{ rad/s}$$

Therefore:

$$a_a = \frac{31.4 - 0}{0.3} = 104.6 \text{ (rad/s}^2\text{)}$$

In conclusion:

$$T_2 = T_{IN} = 2.5 \cdot 104.6 = 261 \text{ Nm}$$

This value has to be taken into account when selecting the motor (approx. $T_{MOT} = (T_2 / i) \cdot R_d$). The driving torque should be high enough as to overcome friction and inertia forces. Subsequently, proceed with the selection of the gearbox on the basis of motor specifications and features of application (operation cycle, no. cycles per hours, etc.) (see selection of the gearbox).

Folglich, im diesem Fall:

$$T_2 = T_{IN} = J \cdot a_a \text{ (Nm)}$$

$J \text{ (kgm}^2\text{)}$ ist das Trägheitsmoment der Masse der Drehscheibe und $a_a \text{ (rad/s}^2\text{)}$ ist die Winkelbeschleunigung.

$$J = (m \cdot r^2) / 2 = (20 \cdot 0.5^2) / 2 = 2.5 \text{ kgm}^2$$

$$a_a = \frac{\omega_1 - \omega_0}{t_a} \text{ (rad/s}^2\text{)}$$

$$\omega_1 = (2 \cdot \pi \cdot n_1) / 60 = (2 \cdot \pi \cdot 300) / 60 = 31.4 \text{ rad/s}$$

Folglich:

$$a_a = \frac{31.4 - 0}{0.3} = 104.6 \text{ (rad/s}^2\text{)}$$

Schließlich:

$$T_2 = T_{IN} = 2.5 \cdot 104.6 = 261 \text{ Nm}$$

Von diesen Wert hängt die Wahl des Motors (annähernd: $T_{MOT} = (T_2 / i) \cdot R_d$) ab. Das Antriebsdrehmoment muss ausreichend hoch sein, um Reibungs- und Trägheitskräfte überwinden zu können. Schließlich wird das Getriebe abhängig von Applikation (Arbeitszyklus, Zyklen pro Stunde, u.s.w.) und Motoreigenschaften gewählt (siehe Wahl des Getriebes).

Calcolo dell'inerzia J / Calculation of inertia J / Berechnung der Trägheit J

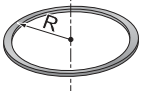
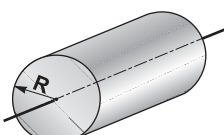
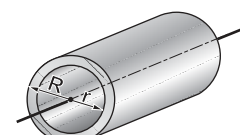
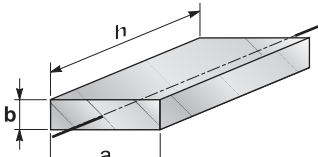
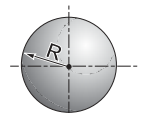
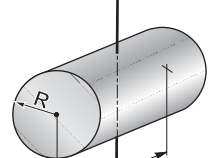
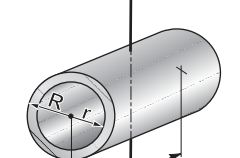
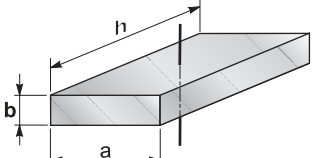
 <p>$J = MR^2$</p>	 <p>$J = \frac{1}{2}MR^2$</p>	 <p>$J = \frac{M(R^2 + r^2)}{2}$</p>	 <p>$J = \frac{M(a^2 + b^2)}{12}$</p>
 <p>$J = \frac{2}{5}MR^2$</p>	 <p>$J = \frac{M}{4} \left(\frac{h^2}{3} + R^2 \right)$</p>	 <p>$J = \frac{M}{4} \left(\frac{h^2}{3} + R^2 + r^2 \right)$</p>	 <p>$J = \frac{M}{12} (h^2 + a^2)$</p>

M	[Kg]	Massa	Weight	Maße
a, b, h	[m]	Dimensioni	Dimensions	Abmessungen
J	[Kgm ²]	Inerzia	Inertia	Trägheitsmoment

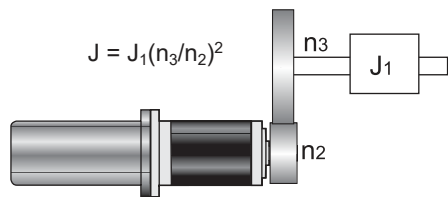

J = inerzia riferita all'albero uscita del riduttore con velocità n_2 [rad/s] derivante da una massa con inerzia J_1 e ruotante a velocità n_3 [rad/s].

J = inertia referred to the gearbox output shaft with speed n_2 [rad/s] resulting from a mass with inertia J_1 rotating at n_3 speed [rad/s].

J = Trägheit mit Bezug auf Getriebeabtriebswelle mit Drehzahl n_2 [rad/s], die von einer Masse mit Trägheit J_1 zu n_3 Drehzahl ableitet [rad/s].

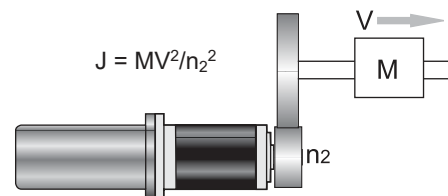

J = inerzia riferita all'albero uscita del riduttore con velocità n_2 [rad/s] derivante da una massa traslante M [Kg] a velocità V [m/s].

J = inertia referred to the gearbox output shaft with speed n_2 [rad/s] resulting from a translating mass M [Kg] at V speed [m/s].

J = Trägheit mit Bezug auf Getriebeabtriebswelle mit Drehzahl n_2 [rad/s], die von einer Translation-Masse M [Kg] zu V Drehzahl [m/s] ableitet.

Relazioni fondamentali fra coppia T [Nm], inerzia J [Kgm²] e accelerazione angolare a_a [rad/s²].

Fundamental relations between torque T [Nm], inertia J [Kgm²] and angular acceleration a_a [rad/s²].

Wesentliche Relationen zwischen Drehmoment T [Nm], Trägheit J [Kgm²] und Winkelbeschleunigung a_a [rad/s²].

$$T = J \cdot a_a$$

Relazioni fondamentali fra coppia e potenza in entrata (T1, P1) e in uscita (T2, P2), il rendimento Rd e il rapporto di riduzione i del riduttore.

Fundamental relations between input torque and power (T1, P1), output torque and power (T2, P2), efficiency Rd, gearbox reduction ratio i.

Wesentliche Relationen zwischen Antriebsdrehmoment und -leistung (T1, P1), Abtriebsdrehmoment und -leistung (T2, P2), Wirkungsgrad Rd, Untersetzungsverhältnis i des Getriebes.

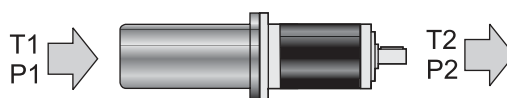

$$P2 = P1 \cdot Rd \quad T2 = T1 \cdot i \cdot Rd$$

5.0

CONDIZIONI GENERALI DI VENDITA

TERMS AND CONDITIONS OF SALE

5.1	Scopo	<i>Purpose</i>	74
5.1.1	Modifiche alle condizioni generali di vendita	<i>Modification of the conditions of sale</i>	74
5.2	Definizioni generali	<i>General definitions</i>	74
5.3	Riferimenti	<i>References</i>	74
5.4	Offerte e ordinazioni	<i>Offers and orders</i>	74
5.4.1	Offerte	<i>Offers</i>	74
5.4.2	Ordini	<i>Orders</i>	75
5.4.3	Conferma d'ordine	<i>Order confirmation</i>	75
5.5	Prezzo dei prodotti	<i>Price of the products</i>	75
5.6	Spedizione e trasporto	<i>Shipping and transport</i>	76
5.7	Termini di consegna	<i>Terms of delivery</i>	76
5.8	Pagamenti	<i>Payments</i>	76
5.8.1	Reclami e/o contestazioni	<i>Claims and / or disputes</i>	76
5.8.2	Non conformità	<i>Non-compliance</i>	77
5.8.3	Restituzione del materiale	<i>Return of material</i>	77
5.8.4	Garanzia dei prodotti	<i>Product warranty</i>	77
5.9	Marchi e diritti di proprietà intellettuale	<i>Trademarks and intellectual property rights</i>	77
5.10	Controversie e risoluzione contrattuale	<i>Disputes and contract termination</i>	78
5.10.1	Clausola risolutiva art. 1455 C.C.	<i>Termination art. 1455 C.C. (Italian Civil Code)</i>	78
5.10.2	Clausola risolutiva art. 1461 C.C.	<i>Termination art. 1461 C.C. (Italian Civil Code)</i>	78

5.1 Scopo

Le presenti "Condizioni Generali di Vendita" (di seguito denominate "Condizioni di Vendita"), si applicano e regolano tutte le forniture di prodotti con marchio "TRAMEC" e/o commercializzate dalla stessa, e annullano qualsiasi clausola o termine pattuito dal Cliente, sia nella singola vendita che in documentazioni di provenienza dello stesso, che non sia stata accettata da un preventivo consenso scritto da parte di "TRAMEC Srl".

5.1.1 Modifiche alle condizioni di vendita

"TRAMEC Srl" si riserva il diritto di modificare, aggiungere, cancellare qualsiasi punto delle presenti Condizioni di Vendita, che si riterranno applicate a tutti gli ordini successivi alla data di notifica al Cliente delle nuove Condizioni di Vendita.

5.2 Definizioni generali

Per una maggiore chiarezza nella lettura delle presenti Condizioni di Vendita, si definiscono i seguenti termini:

- "TRAMEC" : TRAMEC Srl, Via Bizzarri,6 – 4007 Calderara di Reno (BO) - ITALY
- "Prodotti": Tutti i beni prodotti, assemblati, commercializzati e/o venduti da TRAMEC Srl
- "Cliente" : Tutte le società legalmente costituite e/o entità giuridiche che acquistano beni, prodotti o servizi da TRAMEC Srl
- "Ordine" : Ogni proposta di acquisto di beni, prodotti o servizi inoltrata da un cliente a TRAMEC Srl e confermata per accettazione con "Conferma d'ordine" dalla stessa.
- "Marchi" : Tutti i marchi di proprietà di TRAMEC Srl di cui è proprietaria e/o licenziataria
- "Brevetti e Proprietà Intellettuale" : Qualsiasi diritto legato alla protezione del proprio Know-How, coperto da brevetti italiani e internazionali, per invenzioni, marchi, modelli, disegni e prodotti di cui TRAMEC Srl ne detiene ed è proprietaria dei diritti, siano essi registrati ,che in fase di registrazione compresi qualsiasi altra forma prevista dalle leggi internazionali.

5.3 Riferimenti

Il presente documento è parte integrante del "LISTINO PREZZI TRAMEC", di cui copia è pubblicata sul sito aziendale www.tramec.it

5.4 Offerte e ordinazioni

5.4.1 Offerte

Su richiesta del Cliente, TRAMEC direttamente o attraverso la propria rete vendita, formulerà una proposta di acquisto per i propri prodotti indicati dal Cliente, formalizzandola per iscritto. L'offerta di vendita/proposta di acquisto non è da ritenersi impegnativa da parte del Cliente, e avrà validità 30(trenta) giorni. Allo scadere di tale termine, TRAMEC si riterrà svincolata da impegni e su richiesta del cliente riformulerà una nuova offerta/proposta.

Data la natura riservata del contenuto dell'offerta/proposta ricevuta il Cliente, si impegna a non divulgarne il contenuto.

5.1 Purpose

The present "General Conditions of Sale" (hereinafter referred to as "Conditions of Sale"), shall apply and shall govern all supplies of "TRAMEC" products with "TRAMEC" label and / or directly commercialized by "TRAMEC", and cancel any clause or term agreed upon by the Customer which have not been accepted by prior consent in writing by "TRAMEC Srl".

5.1.1 Modification of the conditions of sale

"TRAMEC SRL" reserves the right to modify, add, delete any part of these "Conditions of Sale", which will be deemed to apply to all orders received after the date of Customer's notification.

5.2 General definitions

For a better understanding of these Conditions of Sale, we define the following terms:

- "TRAMEC" : TRAMEC Srl, Via Bizzarri,6 – 4007 Calderara di Reno (BO) - ITALY
- "Products": All goods manufactured, assembled, commercialized and / or sold by TRAMEC Srl.
- "Customers" : All companies legally established and / or legal entities buying goods, products or services from TRAMEC SRL
- "Orders" : Each offer to purchase goods, products or services sent by the Customer to TRAMEC Srl and confirmed for acceptance with an "order confirmation" directly from TRAMEC Srl
- "Trademarks" : All trademarks owned or of which TRAMEC Srl is licensee.
- " Patents and Intellectual Property" : all rights related to the protection of their own Know - How, covered with Italian and international patents for inventions, trademarks, models, designs and products for which TRAMEC SRL holds and owns the rights, whether registered or under registration, including any other form prescribed by the International laws.

5.3 References

This document is an integral part of the "PRICE LIST of TRAMEC", a copy of which is posted on the company website www.tramec.it

5.4 Offers and orders

5.4.1 Offers

On customer request, TRAMEC directly or through its own sales network, will submit a written proposal for the products required by the Customer. The offer shall not be binding for the Customer and will have a 30 (thirty) days validity. After this period the offer is void and upon Customer request TRAMEC will submit a new proposal. TRAMEC written offers are intended for the receipt and viewing of the Customer, and disclosure of the offer with competitors could render the offer null and void.

5.4.2 Ordini

Tutti gli ordini di acquisto dei prodotti TRAMEC, devono essere formalizzati per iscritto dal Cliente su propria carta intestata ed inviati tramite mail, fax o lettera direttamente ai riferimenti indicati nell'offerta/proposta ricevuta, avendo cura di aver indicato:

- Riferimento a n. offerta,
- codice prodotto,
- descrizione prodotto,
- quantità richiesta,
- prezzi e termini di consegna.

TRAMEC ha previsto la possibilità di accettare anche ordini a carattere di "URGENZA" **previ accordi telefonici con il commerciale TRAMEC di riferimento**, che devono essere formalizzati per iscritto dal Cliente, e che prevedono una consegna entro 5 (cinque) oppure 6-9 (da sei a nove) gg lavorativi dalla data di accettazione dell'ordine stesso. A tali ordini verrà applicato una maggiorazione del 15%(quindicipercento) e del 7% (settepercento) rispettivamente, calcolata sul totale lordo EX WORKS dell'ordine, in aggiunta agli importi netti totali.

ATTENZIONE

Tutti gli ordini a carattere d'urgenza, una volta accettati e confermati da TRAMEC, non saranno più modificabili né cancellabili.

5.4.3 Conferma d'ordine

La vendita si riterrà conclusa con l'invio della Conferma d'Ordine che TRAMEC inoltrerà al Cliente. Tale Conferma d'Ordine sarà inoltrata al cliente tramite mail o su richiesta tramite fax direttamente ai riferimenti indicati dal Cliente. La Conferma d'Ordine sarà conforme, all'ordine di acquisto del Cliente ricevuto da TRAMEC, sia nei termini che nelle condizioni indicate e concordate. Trascorsi 2(due) giorni lavorativi dall'invio della Conferma d'Ordine, TRAMEC riterrà confermato l'ordine da parte del Cliente ed ogni inesattezza eventualmente contenuta e non contestata in forma scritta da parte del Cliente e confermata sempre in forma scritta da TRAMEC (con nuova Conferma d'Ordine revisionata), evidenziata alla consegna dei prodotti al Cliente non sarà più contestabile o annullabile.

5.5 Prezzo dei prodotti

Tutti i prezzi dei prodotti indicati negli ordini di vendita, e nelle relative offerte, fanno riferimento al listino prezzi TRAMEC, in vigore al momento del loro inoltro al Cliente. Qualora non fosse presente il prodotto in ordine nel listino prezzi TRAMEC, avrà valore quanto concordato e confermato per iscritto nell'ordine stesso.

Eccetto quanto concordato per iscritto tra le parti, i prezzi indicati nell'ordine di vendita TRAMEC sono calcolati franco fabbrica, al netto dell'IVA e degli sconti. Tali prezzi inoltre non includono eventuali costi di imballaggio, spedizione e trasporto dai locali di TRAMEC ai locali del cliente, che saranno sostenuti separatamente dal Cliente.

TRAMEC manterrà la proprietà dei Prodotti venduti al Cliente fino alla completa corresponsione del prezzo degli stessi. La presente clausola di riserva di proprietà, obbliga il Cliente a compiere tutti gli adempimenti previsti per legge, ove previsto, per rendere valida ed eseguibile nei confronti di tutti i terzi tale vincolo.

TRAMEC si riserva il diritto di modificare unilateralmente e senza preavviso, con effetto immediato i prezzi riportati nel proprio listino, nei casi in cui l'adeguamento sia dovuto a cambiamenti impreveduti di condizioni di mercato delle materie prime o dei tassi di cambio. Ogni modifica verrà comunque comunicata al Cliente ed applicata al successivo ordine ricevuto.

5.4.2 Orders

All purchase orders of TRAMEC products must be formalized in writing by the customer, on his own letterhead and sent via mail, fax or letter directly to the references mentioned in the offer, making sure to add :

- Offer reference number ,
- Product Code,
- Product Description,
- Required Quantity,
- Prices and Terms of Delivery.

*An "URGENT" production option **may be agreed case by case with the sales department of TRAMEC**. To accept the urgent production option , Customer must state in writing, requesting URGENT option, and consider standard shipment of urgent orders to be either 5 (five) or 6-9 (from six to nine) working days from the date of TRAMEC's acceptance of order, depending on availability at order time. Such urgent orders will be charged an additional 15% (fifteen percent) or 7% (seven percent) respectively, calculated on the total EX WORKS value of the order.*

ATTENTION!!!!

Urgent orders, once acknowledged by TRAMEC, are non-cancelable and may not be modified.

5.4.3 Order confirmation

TRAMEC will acknowledge the Customers Order via e mail or on request by fax to the address specified by the Customer. All Orders to be performed are subject to the Terms and Conditions Agreed to between the parties.

The Customer will have two (2) days to review the acknowledgment for errors or inaccuracies to notify TRAMEC for correction, after these two (2) days the Order will be considered acknowledged by the Customer and can no longer be contested or canceled.

5.5 Price of the products

All prices listed on the sales orders, and on offers, refer to the Price List of "TRAMEC" valid at time of their transmission to the Customer.

If the product is not mentioned on the Price List of "TRAMEC", its value will be the one agreed to between the parties in writing.

Unless differently agreed, the prices indicated on the sales order of TRAMEC will be calculated on ex-works basis, VAT and Discounts excluded.

These prices do not include any costs for packaging, shipping and transport from TRAMEC warehouse to the Customer premises, which will be paid separately by the Customer.

TRAMEC will retain the ownership of the Products sold to the customer until their complete payment. Because of this saving clause of ownership, the Customer is due to carry out all formalities required by law, and if necessary, to make such a constraint valid and enforceable against all third.

TRAMEC reserves the right to modify the prices of the price list, unilaterally and without notice, with immediate effect , if the adjustment is due to unexpected changes in market conditions, in raw materials or in exchange rates. Each modification will however be noted and indicated on the Order Acknowledgement and will apply to the next order.

5.6 Spedizione e trasporto

La spedizione viene effettuata tramite vettori nazionali ed internazionali, indicati dal Cliente o in mancanza di indicazioni scelti in autonomia da TRAMEC. La scelta del vettore viene effettuata sulla base di valutazione di convenienza e di garanzia del trasporto che il vettore stesso assicura/certifica. Tutto il materiale viaggia a spese e rischio del Cliente stesso, e si intende accettato dal Cliente all'atto di inizio del trasporto da parte del vettore. Eventuali danni occorsi al materiale durante il trasporto, non sono coperti da garanzia TRAMEC. Come indicato al punto 10.5 PREZZO DEI PRODOTTI, la merce viaggia sempre FRANCO FABBRICA.

5.7 Termini di consegna

I termini di consegna indicati nella Conferma d'Ordine, hanno carattere puramente indicativo e sono da ritenersi fissati salvi imprevisti ascrivibili a circostanze di forza maggiore e che siano fuori dal proprio controllo. A titolo esemplificativo e senza pretesa di esaustività si elenca quanto segue:

- a) Ritardi da parte del cliente a fornire dati tecnici o amministrativi necessari alla spedizione dei prodotti
- b) Difficoltà da parte di TRAMEC nell'acquisizione di materie prime necessarie alla produzione dei prodotti
- c) Scioperi parziali o totali, calamità naturali, difficoltà nel trasporto dei materiali, etc. e tutte le altre cause di forza maggiore
- d) Ritardi dovuti a terzi o allo spedizioniere

Il verificarsi di alcuni degli eventi elencati o di altra natura non elencati, non darà diritto al Cliente di esigere indennizzi di sorta o richiesta di risarcimento danni.

5.8 Pagamenti

TRAMEC a propria discrezione emetterà fattura, salvo accordi scritti tra le parti, all'atto della spedizione dei prodotti o in anticipo all'atto dell'accettazione dell'ordine del Cliente. Tutti i pagamenti sono previsti in EURO, eccetto per accordi commerciali che prevedano altra valuta. I pagamenti devono essere effettuati entro i termini stabiliti indicati nella Conferma d'Ordine, anche in presenza di reclami o contestazioni.

Ogni ritardo o mancato pagamento rispetto ai termini stabiliti darà diritto a TRAMEC di sospendere qualsiasi consegna di prodotti e/o ordine in corso e richiedere al Cliente il pagamento degli interessi bancari così come previsto dalle leggi vigenti nella misura del tasso stabilito da BCE + 7% (Settepercento).

Ogni reclamo e/o contestazione non potrà comunque in nessun modo giustificare la sospensione o il ritardato pagamento.

5.8.1 Reclami e/o contestazioni

Ogni tipologia di reclamo o contestazione dovrà essere formalizzato/a a TRAMEC in forma scritta direttamente all'indirizzo email customer.care@tramec.it o attraverso la sezione "Customer Care" presente sul proprio sito www.tramec.it. Eventuali reclami riferiti a vizi o difetti dei prodotti ricevuti dovranno essere segnalati a TRAMEC, sempre in forma scritta, entro 10 (dieci) gg dalla data di consegna.

Nel caso che tali vizi o difetti si evidenziassero, per la loro natura, successivamente alla data di consegna, essi dovranno essere segnalati, sempre in forma scritta, a TRAMEC immediatamente entro e non oltre 5 (cinque) gg dalla data di rilevazione, e comunque saranno ritenuti tali entro e non oltre l'anno di garanzia previsto per i prodotti TRAMEC.

Le spese di trasporto sono a carico del Cliente salvo diverso accordo tra le parti.

5.6 Shipping and transport

Shipments will be handled by national and international carriers specified by the Customer, if specific instructions are not included they will be at TRAMEC's discretion. Where shipment is made at TRAMEC's discretion, carrier choice will be made based on convenience and delivery terms assured by the carriers. Goods are sold to Customer and considered EX-WORKS (see 10.5.PRICE OF THE PRODUCTS), all transportation expense, loss, damages, or delays to be the risk and responsibility of the Customer and their carrier, and not subject to TRAMEC warranty written or implied.

5.7 Terms of delivery

Delivery terms mentioned in "TRAMEC" Order Confirmation are considered agreed upon and to be honored bearing unexpected events outside "TRAMEC" control, in example:

- a) The Customers delay of technical or administrative information necessary for the timely dispatch of the products.*
- b) Difficulties in the acquisition of raw materials required to manufacture TRAMEC products.*
- c) Total or partial labor strikes, natural disasters, transportation difficulties or other circumstances beyond TRAMEC control.*
- d) Delays due to third parties or to be inbound shipping company*

The occurrence of some of the events listed or other not listed, do not entitle the customer to claim any compensation or claim for damages.

5.8 Payments

Unless stated in writing and agreed upon, "TRAMEC" will invoice the Customer on Confirmation of Order for Customers with Prepaid Terms, or at time of shipment for the Customers with NET trade credit terms. Payments are to be made in EURO, except where specific commercial agreements are made in alternative currencies. Payments must be made within the stated NET terms offered at time of Order Confirmation, regardless of outside claims or conflicts.

Delay or missing payments outside of the agreed terms will afford TRAMEC the right to suspend any delivery of products, services, and any pending orders, as well as require the Customer to pay interest on past due invoices, as provided by law, to the extent determined by the ECB rate + 7% (seven percent)

NO claim or dispute can justify the suspension, delay, or non-payment of invoices due.

5.8.1 Claims and / or disputes

Each complaint or claim must be transmitted in writing to "TRAMEC", directly to the e mail address customer.care@tramec.it or through the website www.tramec.it, "Customer Care" section.

Any claim relating to defect must be reported in writing to "TRAMEC" within 10 (ten) days of the receipt of the product.

If a defect is noticed or occurs after the delivery date, it must be reported in writing to TRAMEC within 5 (five) days of the date the defect was detected, and always within the 1 (one) year warranty provided for TRAMEC products.

Transportation costs are borne by the Customer unless otherwise agreed to by TRAMEC and the Customer.

5.8.2 Non conformità

Eventuali non corrispondenze in tipologia del prodotto e/o quantità, rispetto a quanto indicato in Conferma d'Ordine, dovrà essere prontamente segnalata in forma scritta a TRAMEC o al proprio agente di riferimento entro e non oltre 5(cinque) gg dalla data di consegna del materiale. Dopo tale scadenza i prodotti consegnati si riterranno conformi all'ordine del Cliente e non potranno essere più contestati a TRAMEC. Le spese di trasporto sono a carico del Cliente salvo diverso accordo tra le parti.

5.8.3 Restituzione del materiale

Il materiale non può essere restituito a TRAMEC, senza preventiva autorizzazione scritta da parte della stessa. Eventuali materiali ricevuti senza che il Cliente abbia effettuato una segnalazione scritta così come previsto ai punti 5.8.1 e 5.8.2, ed autorizzata da TRAMEC, verranno respinti al mittente, con addebito delle spese di trasporto salvo diverso accordo tra le parti.

5.8.4 Garanzia dei prodotti

TRAMEC garantisce i propri prodotti, così come previsto dalle leggi vigenti, per un periodo di 1(uno) anno dalla data di fatturazione degli stessi. La garanzia opererà su tutti i prodotti TRAMEC, ove saranno rilevabili difetti di costruzione, montaggio o progettazione e comporterà per TRAMEC l'onere della sostituzione o riparazione delle parti difettose senza nessun altro aggravio e/o addebiti per danni diretti e/o indiretti di qualsiasi natura.

La garanzia decade nel caso siano state eseguite riparazioni, modifiche o manomissioni senza autorizzazione scritta da parte di TRAMEC e nel caso di mancanza della targhetta originale di fabbrica, presente su tutti i prodotti TRAMEC.

Un uso negligente o improprio e inosservanza delle prescrizioni sull'uso, manutenzione e conservazione dei prodotti, comporterà la decadenza immediata della garanzia. Il prodotto, coperto da garanzia, dovrà essere restituito a TRAMEC, così come indicato al punto 5.8.3, con spese di trasporto a carico del Cliente salvo diverso accordo tra le parti. La proprietà del prodotto o componente sostituito in garanzia, ove risultasse difettoso, sarà trasferita a TRAMEC dal Cliente.

Ogni diritto di garanzia non sarà applicabile, su quei prodotti a cui ancora non siano stati completamente corrisposti, alle condizioni e termini pattuiti, i relativi importi dovuti così come da fattura di riferimento. TRAMEC inoltre non garantisce nessuna garanzia circa alle conformità dei prodotti a norme e regolamenti di Paesi o Stati che non rientrano e appartengano alla Comunità Europea.

5.9 Marchi e diritti di proprietà intellettuale

TRAMEC è l'unica titolare dei propri Marchi, ed il Cliente si asterrà dall'utilizzo degli stessi senza preventiva autorizzazione, o registrare Marchi simili e/o confondibili con i medesimi. Ogni loro utilizzo comunque dovrà essere autorizzato in forma scritta da TRAMEC sia nelle modalità che nella forma, secondo indicazioni concordate con il titolare dei Marchi.

Tutti i diritti di Proprietà Intellettuale sono di totale ed esclusiva proprietà di TRAMEC e la loro comunicazione o utilizzo nell'ambito delle presenti "Condizioni Generali di Vendita" non produce nessun diritto o pretesa in capo al Cliente, che si obbliga a non compiere atti o richieste a contestarne la Titolarità e Proprietà.

5.8.2 Non-compliance

Any non-compliance with either product or its quantity found to be different from what is stated on Order Confirmation, must be reported in writing to TRAMEC or its Agent, no later than 5 (five) days from the delivery date of the material.

With no notification made after this time, the products will be considered complying with the order acknowledged to the Customer and shall no longer be contested to TRAMEC. Transportation costs are borne by the Customer unless otherwise agreed to by TRAMEC and the Customer.

5.8.3 Return of material

No goods or materials can be returned without "TRAMEC" prior written authorization. Materials received without authorization and written report from the Customer, as required in point 5.8.1 & 5.8.2, and fully authorized by "TRAMEC", will be returned to the sender at the senders expense for all transportation and customs fees, unless otherwise agreed to between the parties in writing.

5.8.4 Product warranty

"TRAMEC" guarantees its products, as provided by law, for a period of 1 (one) year from the date of invoice. This guarantee will be valid for all "TRAMEC" products, where construction, installation or design defects will be detected and will lead to "TRAMEC" the burden of replacement or repair of defective parts at its discretion without any other burden or responsibility or charges for any direct and / or indirect damages or expense.

"TRAMEC" warranty is void if repairs, changes or alterations are carried out on the product without the written consent of "TRAMEC", and only valid with the original nameplate which is found on all "TRAMEC" products.

The negligent or improper use as well as failure to observe regulations governing the utilization, maintenance and storage of products, will result in the immediate loss of this guarantee. The product, covered by the warranty, will have to be returned to "TRAMEC" free of charge, as indicated in point 5.8.3, with all transportation costs borne by the Customer unless otherwise agreed between the parties in writing. The product or component replaced under warranty, if it is defective, will belong to "TRAMEC".

The warranty will not be valid for products that are not paid in full, according to the conditions and terms agreed, and for the amounts due per relevant invoice.

"TRAMEC" provides no guarantee as for the conformity of their products with the standards and regulations of Countries or States not belonging to the European Community.

5.9 Trademarks and intellectual property rights

TRAMEC is the sole owner of its brands, and the Customer will refrain from the use of them without prior authorization, or register similar ones and/or brands that are easily confused with TRAMEC's brands. Every use of TRAMEC brands requires the authorization in writing by TRAMEC, both in terms and form, according to instructions agreed with the owner of these trademarks.

All Intellectual Property Rights are the complete and exclusive property of TRAMEC and their communication or use under these "Terms of Sale" does not product any right or claim to the Customer, which is obliged to refrain from acts or request to question the Possessory title and Property.

5.10 Controversie e risoluzione contrattuale

Tutte le controversie derivanti da o connesse alle presenti Condizioni di Vendita e/o ad ogni vendita, sono assoggettabili alla esclusiva giurisdizione del Foro competente di Bologna (ITALIA).

TRAMEC Srl è legalmente domiciliata presso la sua sede principale di Via Bizzarri,6 – 40007 Calderara di Reno(BO) – ITALY.

5.10.1 Clausola risolutiva art. 1455 C.C.

TRAMEC avrà facoltà di risolvere, ai sensi e per gli effetti dell'art. 1455 del Codice Civile Italiano, in qualsiasi momento con comunicazione scritta al Cliente, la singola vendita nel caso di inadempimento delle obbligazioni così come previsto ai punti 5.5 (Prezzo dei Prodotti), 5.8 (Pagamenti), 5.9 (Marchi e Diritti di Proprietà Intellettuale).

5.10.2 Clausola risolutiva art. 1461 C.C.

TRAMEC avrà diritto di sospendere, ai sensi e per gli effetti dell'art. 1461 del Codice Civile Italiano, in qualsiasi momento con comunicazione scritta al Cliente, tutte le obbligazioni in corso derivanti dalla vendita dei prodotti, nel caso in cui le condizioni patrimoniali del Cliente divenissero e/o risultassero tali da porre in serio dubbio la naturale acquisizione della contropartita prevista.

TRAMEC potrà valutare eventuali garanzie accessorie proposte dal Cliente, come assicurazione sulle obbligazioni in essere.

5.10 Disputes and contract termination

All disputes due or related to these "Terms of Sale" and / or any sale, are subject to the exclusive jurisdiction of the Competent Court of Bologna (ITALY).

TRAMEC SRL is legally domiciled at its headquarters in Via Bizzarri, 6-40007 Calderara di Reno (BO) - ITALY.

5.10.1 Termination art. 1455 C.C. (Italian Civil Code)

"TRAMEC" may terminate, pursuant to art. 1455 of the Italian Civil Code, at any time by written notice to the Customer, the single sale in the event of breach of the obligations as set out in paragraphs 5.5 (Product Price), 5.8 (Payments), 5.9 (Trademarks and Intellectual Property Rights).

5.10.2 Termination art. 1461 C.C. (Italian Civil Code)

"TRAMEC" will be entitled to suspend, pursuant to art. 1461 of the Italian Civil Code, at any time by written notice to the Customer, all current obligations arising from the sale of the products, in the event that the financial conditions of the Customer would become and/or result to call into serious doubt the natural acquisition of expected offset.

"TRAMEC" may consider any additional guarantees proposed by the Customer, such as insurance on outstanding obligations.

04/2021

Questo catalogo annulla e sostituisce ogni precedente edizione o revisione.

Tutti i dati elencati sono indicativi e s'intendono senza impegno alcuno da parte nostra.

Ci riserviamo il diritto di apportare modifiche senza preavviso.

This catalogue cancels and replaces any previous edition and revision.

All listed data are approximate and it's understood that this entails no obligation on our part.

We reserve the right to implement modifications without notice.

Mit der Ausgabe dieses Katalogs annullieren sich gleichzeitig alle bisherigen Katalogen.

Sämtliche Daten sind Berechnete Werte die für den Verkäufer unverbindlich sind.

Der Verkäufer behält sich das Recht vor, Änderungen, ohne eine vorhergehende Advisierung durchzuführen.

GAMME DI PRODOTTO
RANGE OF PRODUCTS

Riduttori a vite senza fine / Worm gearboxes
Riduttori a ingranaggi / Helical and bevel helical gearboxes
Riduttori epicicloidali di precisione / Precision planetary gearboxes
Riduttori speciali / Special gearboxes
Variatori di velocità / Mechanical variators



Ihr Service- und Vertriebspartner:
TRAMEC Getriebe GmbH
Senefelderstraße 3
77933 Lahr / Schwarzwald
Tel.: 07821-99 49 701
info@tramec-getriebe.de
www.tramec-getriebe.de

