

ATEX

ATMOSFERE ESPLOSIVE

MADE IN ITALY

ATEX
Explosive
Atmospheres

ATEX
Explosive
Atmosphären





Il gruppo TRAMEC

TRAMEC vanta una presenza in ben 68 paesi nei 5 continenti, presupposto essenziale per occupare una posizione di spicco nel settore.

Le aziende produttive del gruppo e le relative filiali rappresentano un vero e proprio presidio territoriale di carattere commerciale e logistico ed affiancano il cliente con attività di pre e post-vendita, partendo dalla fase di progettazione e coprendo l'intero ciclo di vita del prodotto.

Questa organizzazione permette a **TRAMEC** di proporsi quale fornitore completo e versatile, nonché altamente professionale, nel mondo delle trasmissioni meccaniche.

The TRAMEC Group

TRAMEC has a presence in as many as 68 countries on 5 continents, a prerequisite for occupying a leading position in the industry.

The group's production companies and their subsidiaries represent a real territorial presence of a commercial and logistical nature and support the customer with pre- and after-sales activities, starting from the design phase and covering the entire product life cycle.

*This organisation allows **TRAMEC** to present itself as a complete, versatile and highly professional supplier in the world of mechanical transmissions.*

Die Gruppe TRAMEC

TRAMEC ist in 68 Ländern auf fünf Kontinenten vertreten, eine Voraussetzung, um eine führende Position in der Branche einzunehmen.

Die Produktionsgesellschaften der Gruppe und ihre Tochtergesellschaften stellen eine echte territoriale Größe kommerzieller und logistischer Art dar und unterstützen den Kunden mit Pre- und After-Sales-Aktivitäten, beginnend mit der Planungsphase und über den gesamten Produktlebenszyklus hinweg.

Diese Organisation ermöglicht es **TRAMEC**, sich als kompletter, vielseitiger und hoch professioneller Lieferant in der Welt der mechanischen Getriebe zu präsentieren.

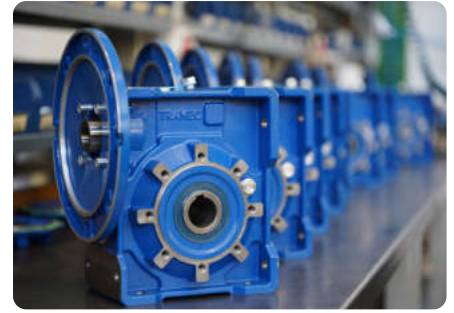

Vision aziendale

La filosofia di **TRAMEC** è da sempre incentrata sui seguenti punti cardine:

- Il perseguimento dell'eccellenza produttiva e qualitativa con una produzione rigorosamente **100% MADE IN ITALY**.
- Il fattore umano nel rapporto con i dipendenti, clienti e collaboratori.
- La ricerca continua di soluzioni innovative.

Company Vision

TRAMEC's philosophy has always been centred on the following cornerstones:

- *The pursuit of production and quality excellence with strictly **100% production MADE IN ITALY**.*
- *The human factor in the relationship with employees, customers and collaborators.*
- *The continuous search for innovative solutions.*

Unternehmensphilosophie

Die Philosophie von **TRAMEC** basiert seit jeher auf den folgenden Eckpfeilern:

- Das Streben nach hervorragender Produktion und Qualität mit konsequent **100%iger** Produktion **MADE IN ITALY**.
- Der menschliche Faktor im Umgang mit Mitarbeitern, Kunden und Kooperationspartnern.
- Die ständige Suche nach innovativen Lösungen.

Mission aziendale

- Essere un partner di riferimento a livello internazionale per la progettazione, realizzazione e commercializzazione di soluzioni avanzate ed affidabili nel settore delle trasmissioni di potenza.
- Fornire ai clienti un supporto rapido e puntuale, dalla fase di progettazione fino al post-vendita.
- Continuo miglioramento dei processi e prestazioni nel proprio Sistema di Gestione Integrata.

Company Mission

- *To be an international reference partner for the design, realisation and marketing of advanced and reliable solutions in the power transmission sector.*
- *Providing customers with fast and timely support, from the design phase to after-sales.*
- *Continuous improvement of processes and performance in its Integrated Management System.*

Mission des Unternehmens

- Ein internationaler Referenzpartner für die Planung, Realisierung und Vermarktung von fortschrittlichen und zuverlässigen Lösungen im Bereich der Energieübertragung zu sein.
- Schnelle und rechtzeitige Unterstützung der Kunden von der Entwurfsphase bis zum After-Sales-Service zu gewährleisten.
- Kontinuierliche Verbesserung der Prozesse und Leistungen im Rahmen des integrierten Managementsystems zu erzielen.

Ambiente, salute e sicurezza

TRAMEC si distingue tramite una produzione che rispetta l'ambiente e si attiene alle direttive e alle norme nel rispetto di tutti gli stakeholders. Ciò significa la riduzione del consumo di materie prime, l'impiego efficiente dell'energia, l'utilizzo attento e responsabile delle sostanze inquinanti, la diminuzione dell'emissione dei rifiuti e l'attuazione di tutte le forme di sicurezza sul lavoro.

Environment, health and safety

TRAMEC distinguishes itself through environmentally friendly production and adheres to guidelines and standards in respect of all stakeholders. This means the reduction of raw material consumption, the efficient use of energy, and the careful and responsible use of pollutants, the reduction of waste emissions and the implementation of all forms of occupational safety.

Umwelt, Gesundheit und Sicherheit

TRAMEC zeichnet sich durch eine umweltfreundliche Produktion aus und hält sich an Richtlinien und Standards gegenüber allen Beteiligten. Das bedeutet die Reduzierung des Rohstoffverbrauchs, die effiziente Nutzung von Energie und den sorgfältigen und verantwortungsvollen Umgang mit Schadstoffen, die Verringerung der Abfallemissionen und die Umsetzung aller Formen des Arbeitsschutzes.

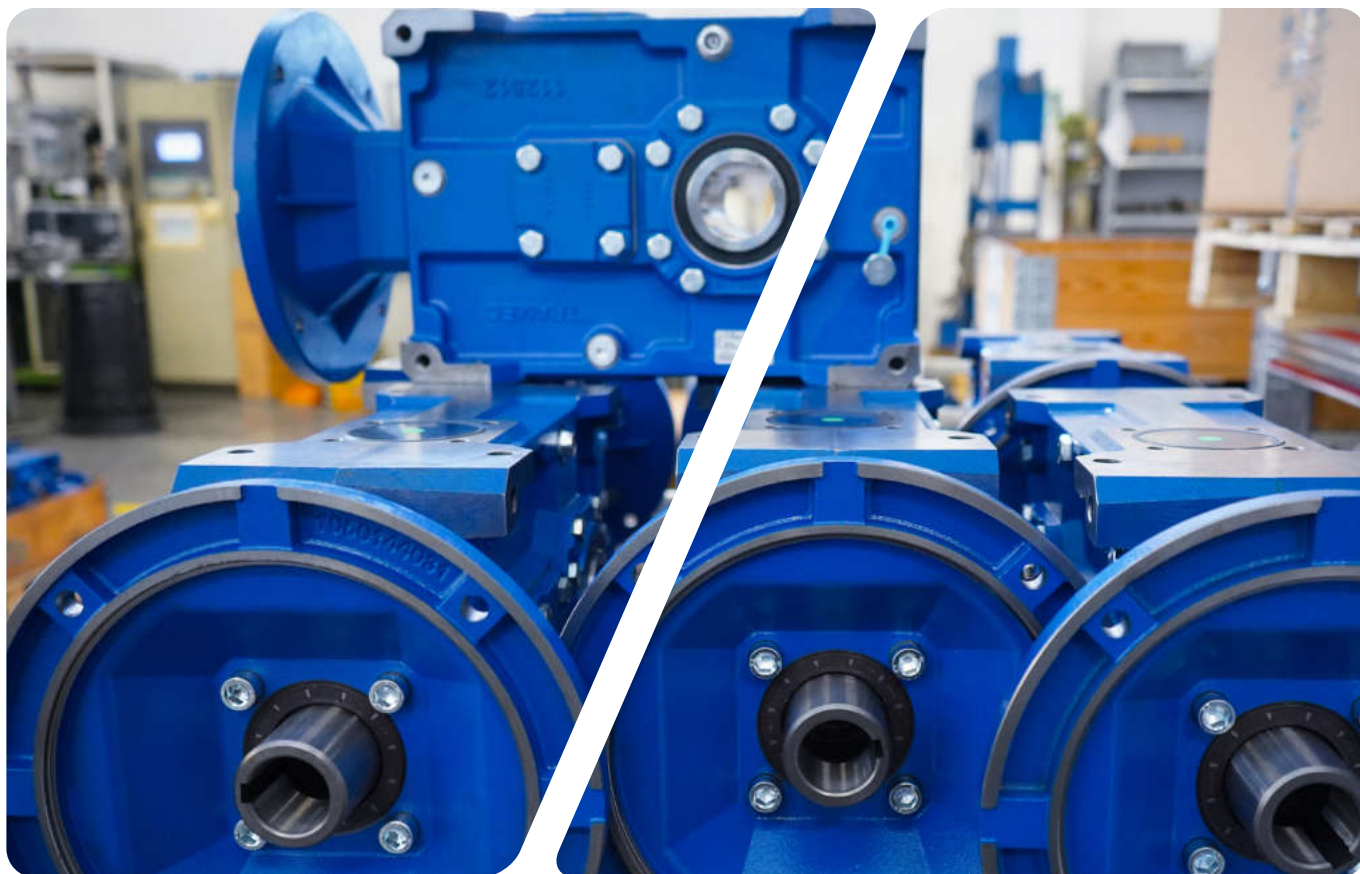

Riduttori per ogni esigenza

TRAMEC nasce nel 1986 a Calderara di Reno, nel cuore della cosiddetta "Motor Valley", una porzione di territorio compresa tra Bologna e Modena celebre per essere la patria delle eccellenze del **MADE IN ITALY** nei settori automobilistico, motociclistico e della meccanica di precisione.

Fin dalla sua fondazione, **TRAMEC** si è specializzata nella produzione di riduttori ad ingranaggi ad alberi ortogonali, paralleli, pendolari e di rinvii angolari, ampliando nel tempo la propria gamma con nuove linee di prodotto come i riduttori epicicloidali di precisione ed i riduttori a vite senza fine. Successivamente l'offerta è stata ampliata con i motori elettrici e gli azionamenti per l'automazione.

L'obiettivo dell'azienda è quello di fronteggiare un mercato in continua evoluzione sul piano delle strategie di competitività qualitativa, economica e di presenza, attraverso un adeguato supporto offerto da tutti i propri reparti (produzione, tecnico e commerciale) e di una rete vendita ramificata e altamente competente.

Gearboxes for every need

TRAMEC was founded in 1986 in Calderara di Reno, in the heart of the so-called "Motor Valley", a portion of territory between Bologna and Modena famous for being the home of **MADE IN ITALY** excellence in the automotive, motorbike and precision mechanics sectors.

Since its foundation, **TRAMEC** has specialised in the production of orthogonal, parallel and shaft-mounted gearboxes and bevel gearboxes, expanding its range over time with new product lines such as precision planetary gearboxes and worm gearboxes. Subsequently, the offer was expanded with electric motors and drives for automation.

The company's aim is to cope with an ever-changing market in terms of qualitative, economic and presence competitiveness strategies through adequate support offered by all its departments (production, technical and commercial) and a branched and highly competent sales network.

Getriebe für jedes Bedürfnis

TRAMEC wurde 1986 in Calderara di Reno gegründet, im Herzen des so genannten "Motor Valley", einem Gebiet zwischen Bologna und Modena, das als Heimat der **MADE IN ITALY-Exzellenz** in den Bereichen Automobil, Motorrad und Feinmechanik bekannt ist.

Seit seiner Gründung hat sich **TRAMEC** auf die Herstellung von Kegetrad-, Stirnrad- und Aufsteckgetrieben sowie Winkelgetrieben spezialisiert und sein Angebot im Laufe der Zeit um neue Produktlinien wie Präzisionsplanetengetriebe und Schneckengetriebe erweitert. Später wurde das Angebot um Elektromotoren und Antriebe für die Automatisierung erweitert.

Das Ziel des Unternehmens ist es, einem sich hinsichtlich der Strategien qualitativer, wirtschaftlicher und präsender Wettbewerbsfähigkeit ständig verändernden Markt durch angemessene Unterstützung aller Abteilungen (Produktion, Technik und Handel) und ein verzweigtes und hochkompetentes Vertriebsnetz zu stellen.

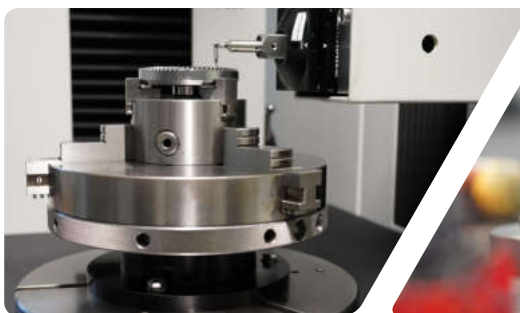

Siti produttivi
Production sites
Produktionsstätten



Filiali Italia
Branches Italy
Niederlassungen in Italien



Filiali Estere
Foreign Branches
Ausländische Niederlassungen



Tramec srl
Via Bizzarri, 6
40012 Calderara di Reno
Bologna (Italy)
www.tramec.it

MT Motori Elettrici srl
Via Bologna, 175
40017 San Giovanni in Persiceto
Bologna (Italy)
www.electricmotorsmt.com

Ber-Mar srl
Via C. Bassi, 28/A
40015 San Vincenzo di Galliera
Bologna (Italy)
www.bermar.it

Varmec srl
Via dell'Industria, 13
36016 Thiene
Vicenza (Italy)
www.varmec.com

Ital.Tech srl
Via C. Bozza SNC
06073 Ellera di Corciano
Perugia (Italy)
www.italtech.info

Tramec Sud srl
Via Gorga, 17
Zona Industriale - LOTTO 17
80036 Palma Campania
Napoli (Italy)
www.tramecsud.it

Tramec Technology srl
Via Leonardo da Vinci, 179
24043 Caravaggio
Bergamo (Italy)
www.tramectechnology.it

Tramec Getriebe gmbh
Senefelderstraße, 3
77933 Lahr
Germany
www.tramec-getriebe.de

Sarl Tramec France
145 Impasse des clos
ZAE Planbois
74550 Perrignier
France
www.tramec.fr

Tramec Polska SP. ZOO
Słoneczna, 1
66-130 Bojadła
Poland
www.tramec.pl

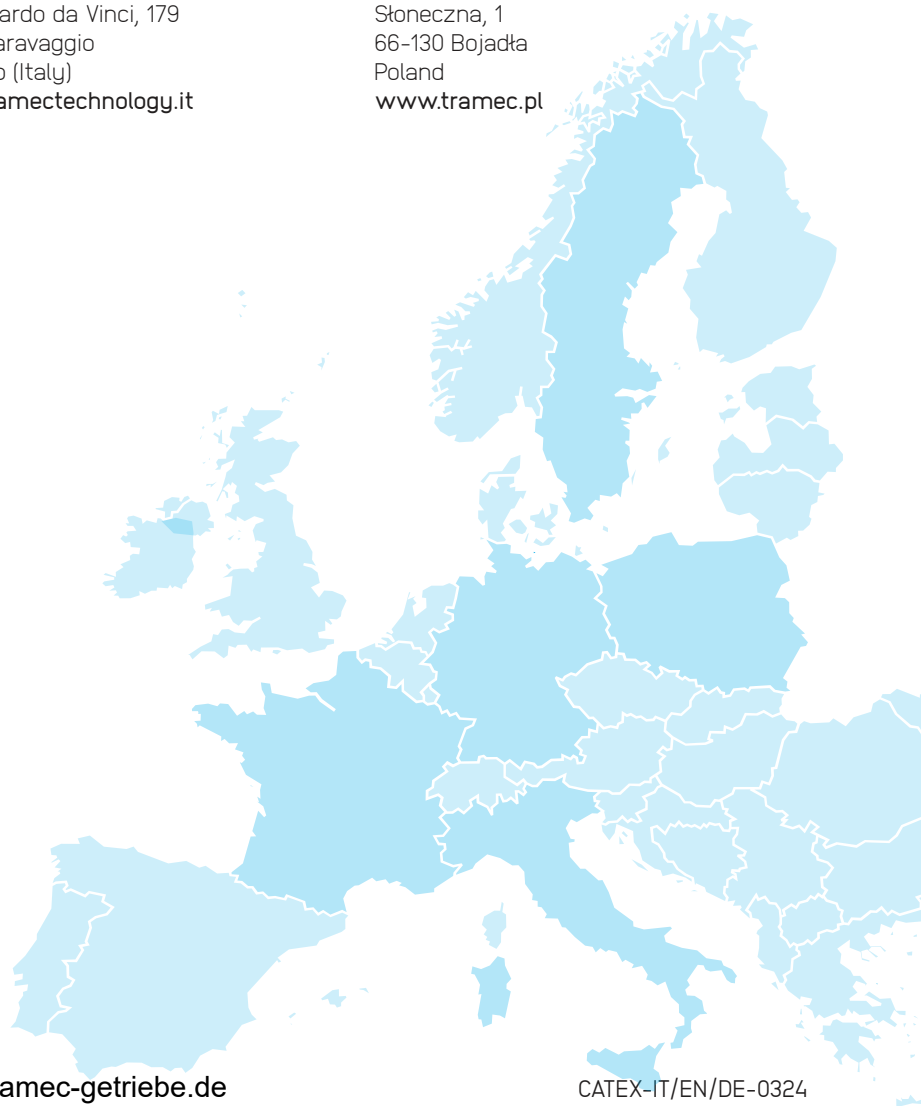

Gamma prodotti

I prodotti **TRAMEC** coprono una vasta gamma di esigenze, e sono presenti in diverse applicazioni.

Robotica, automazione macchine utensili, macchine per la stampa, macchine automatiche per confezionamento ed imballaggio, manipolatori, macchine serigrafiche, guide lineari, macchine per lavorazione del legno sono alcuni degli esempi dove trovano utilizzo.

Product range

TRAMEC products cover a wide range of needs, and can be found in various applications.

Robotics, machine tool automation, printing machines, automatic wrapping and packaging machines, manipulators, screen printing machines, linear guides, woodworking machines are some of the examples where they are used.

Produktbereich

Die Produkte von **TRAMEC** decken eine breite Palette von Bedürfnissen ab und sind in verschiedenen Anwendungen zu finden.

Robotik, Automatisierung von Werkzeugmaschinen, Druckmaschinen, automatische Verpackungsmaschinen, Manipulatoren, Siebdruckmaschinen, Linearführungen, Maschinen für die Holzbearbeitung sind einige Beispiele für die Anwendung.

TRAMEC

Riduttori ad ingranaggi ortogonali e paralleli

Gear reducers orthogonal and parallel

Rechtwinklige und parallele Untersetzungsgetriebe



Riduttori a vite senza fine

Worm gear reducers

Schneckengetriebe



Riduttori epicicloidali

Planetary gearboxes

Planetengetriebe



Riduttori linea GHA

GHA line reducers

GHA-Leitungsreduzierer



BER-MAR

Prodotti / Products / Produkte



MT Motori elettrici

Prodotti / Products / Produkte



VARMEC

Prodotti / Products / Produkte



Il presente catalogo annulla e sostituisce i precedenti.
I dati riportati nel presente catalogo sono indicativi e non impegnativi.

La **TRAMEC srl** si riserva di modificare dati numerici, disegni ed ogni altra informazione contenuta nel presente documento senza preavviso alla gentile clientela.

This catalogue cancels and replaces the previous ones.
The data in this catalogue is indicative and not binding.

TRAMEC srl reserves the right to modify numerical data, drawings and any other information contained in this document without prior notice to customers.

Dieser Katalog annulliert und ersetzt die vorhergehenden Kataloge.
Die Angaben in diesem Katalog sind unverbindlich.

TRAMEC srl behält sich das Recht vor, numerische Daten, Zeichnungen und alle anderen in diesem Dokument enthaltenen Informationen ohne vorherige Ankündigung an die Kunden zu ändern.

INDICE	INDEX	INHALTSVERZEICHNIS	
GENERALITÀ	GENERAL INFORMATION	ALLGEMEINES	A8
Informazioni generali	<i>General information</i>	Allgemeine Hinweise	A9
Responsabilità del costruttore	<i>Responsability of the manufacturer</i>	Haftung des Herstellers	A9
Informazioni sulla sicurezza in atmosfera potenzialmente esplosiva	<i>Information on safety in a potentially explosive atmosphere</i>	Sicherheit in Explosionsgefährdeten Bereichen	A10
Conformità alle direttive	<i>Compliance with directives</i>	Konformität mit der Richtlinie	A11
Limiti e condizioni di impiego	<i>Limits and conditions of operation</i>	Betriebsbedingungen und Verwendungsbereiche	A12
Identificazione dell'apparecchiatura	<i>Identification of the equipment</i>	Getriebebeschreibung	A12
 ATEX 2014/34 UE GRUPPO II cat. 2 ZONA 1 - 21	<i>ATEX 2014/34 EU GROUP II cat. 2 ZONE 1 - 21</i>	ATEX 2014/34 EU GRUPPE II Kat. 2 ZONE 1 - 21	B1
 ATEX 2014/34 UE GRUPPO II cat. 3 ZONA 2 - 22	<i>ATEX 2014/34 EU GROUP II cat. 3 ZONE 2 - 22</i>	ATEX 2014/34 EU GRUPPE II Kat. 3 ZONE 2 - 22	C1
CONDIZIONI GENERALI DI VENDITA	TERM AND CONDITIONS OF SALE	ALLGEMEINE VERKAUFSBEDINGUNGEN	D1

Informazioni generali

Il manuale è stato creato per fornire tutte le informazioni necessarie al personale autorizzato e qualificato (definito secondo IEC 364) per svolgere in sicurezza le attività di trasporto, movimentazione, installazione, avviamento, manutenzione e stoccaggio dei riduttori ad ingranaggi Tramec conformi alla Direttiva ATEX 2014/34/UE.

La direttiva riguarda tutti i dispositivi, compresi quelli meccanici che, impiegati in ambiente con Atmosfera potenzialmente esplosiva, possono diventare una potenziale sorgente di innesco e quindi provocare un'esplosione. La normativa regolamenta:

1. tutti i prodotti che da tale data vengono:

- immessi per la prima volta sul mercato UE
- messi in servizio per la prima volta sul mercato UE

2. tutti i prodotti usati, riparati, modificati e i pezzi di ricambio con le seguenti modalità:

General information

This manual is to give all necessary information to the personnel who are authorized and qualified (as defined in IEC 364) to safely carry out transport, handling, installation, starting, maintenance and storage of Tramec gearboxes in compliance with ATEX Directive 2014/34/EC.

The Directive pertains all equipment, also mechanical, designed for operation in environments with a potentially explosive atmosphere and which can therefore become a possible ignition source for an explosion. The Directive concerns:

1. all products that from the above mentioned date are:

- put for the first time on the EU market
- put into service for the first time in the EU territory

2. all products used, repaired, modified and the spare parts, according to the following:

Allgemeine Hinweise

Diese Betriebsanleitung enthält alle nötigen Informationen, damit das berechnete Fachpersonal (wie es in IEC 364 definiert wird), Transport, Verlagerung, Installation, Anlassen, Wartung und Lagerung der Tramec Getriebe gemäß ATEX-Richtlinie 2014/34/UE mit Sicherheit durchführt.

Die Richtlinie betrifft neben elektrischen auch mechanischen Geräte, die eigene potentielle Zündquellen aufweisen und deswegen eine Explosion verursachen können, falls sie in Umgebungen mit explosionsfähiger Atmosphäre verwendet werden. Die Richtlinie betrifft:

1. Produkte, die seit dem oben angegebenen Datum zum ersten Mal

- auf dem EU-Markt in Verkehr gebracht werden
- auf dem EU-Markt in Betrieb genommen werden

2. Gebrauchte Produkte, reparierten und modifizierten Produkte und Ersatzteile:

		DEFINIZIONE A NORMATIVA DEFINITION AS PER DIRECTIVE BESTIMMUNG NACH RICHTLINIE		
TIPOLOGIA DI PRODOTTO TYPOLOGY OF PRODUCT ART VON PRODUKT	Usati e di seconda mano	Prodotti immessi e/o messi in servizio sul mercato UE prima dell'entrata in vigore della direttiva 2014/34/UE	NO	APPLICABILITÀ DELLA NORMATIVA ENFORCEABILITY OF THE DIRECTIVE ANWENDBARKEIT DER RICHTLINIE
	Used and second-hand	Products which were put on the EU market and/or put into service in the EU prior to the coming into force of ATEX Directive 2014/34/EC.	NO	
	Gebraucht und aus zweiter Hand	Produkte, die vor Inkrafttreten der Richtlinie 2014/34/UE auf dem EU-Markt in Verkehr gebracht und innerhalb der EU in Betrieb genommen wurden.	NEIN	
	Usati d'importazione Extracomunitaria	Se resi disponibili per la prima volta nell'UE dopo il 30/06/2003 per essere distribuiti e/o utilizzati nell'UE.	SI	
	Used and imported from non-European countries	Products made available for the first time in the EU after 30/06/2003, for the purpose of distribution and/or use in the EU.	YES	
	Aus einem Nicht-EU-Land importierten Gebrauchtprodukt	Produkte, die nach 30/06/2003 zum ersten Mal in der EU zum Zwecke des Vertriebs und / oder der Verwendung verfügbar gemacht wurden.	JA	
	Revisionati e/o rimessi a nuovo	Prodotti già presenti sul mercato ed utilizzati nell'UE, le cui prestazioni si sono modificate nel tempo (a causa di vetustà, obsolescenza, ecc) e che sono stati ripristinati mediante interventi esteriori e/o di tipo estetico senza modifiche sostanziali	NO	
	Reconditioned and/or refurbished	Products already available on the market and used in the EU, whose performance has changed over time (owing to ageing, obsolescence, etc) and which have been restored, through external modification or cosmetic operation, but have not undergone any substantial change.	NO	
	Wieder-instandgesetzt und/oder saniert	Altprodukte, die sich in der EU in Verkehr befanden und gebraucht wurden, deren Eigenschaften sich jedoch im Laufe der Zeit (infolge von Alterung, Veralterung, u.s.w.) geändert haben, und die durch kosmetischen und/oder ästhetischen Eingriff ohne erhebliche Modifizierung wiederhergestellt wurden.	NEIN	
Riconfigurati	Prodotti usati già presenti sul mercato ed utilizzati nell'UE, ma la cui configurazione è stata modificata mediante l'aggiunta (upgrading) o l'eliminazione (downgrading) di una o più parti (componenti, sub-unità come schede o moduli di tipo "plug-in", ecc.) senza quindi sostanziali modifiche.	NO		
Reconfigured	Products available and used in the EU, but whose configuration has been modified by the addition (upgrading) or the removal (downgrading) of one or more parts (components, sub-assemblies such as plug-in cards or modules, etc.) therefore with no substantial changes.	NO		
Rekonfiguriert	Produkte, die sich innerhalb der EU in Verkehr oder Gebrauch befanden, deren Konfiguration jedoch durch Zugabe (Funktions- oder Leistungserhöhung) oder Entfernung (Funktions- oder Leistungsminderung) von einem oder mehreren Teilen (Komponenten, Teilbaugruppe wie Einschubkarten oder Module, u.s.w.) ohne erhebliche Änderung modifiziert wurden.	NEIN		

		DEFINIZIONE A NORMATIVA DEFINITION AS PER DIRECTIVE BESTIMMUNG NACH RICHTLINIE		
TIPLOGIA DI PRODOTTO TYPOLOGY OF PRODUCT ART VON PRODUKT	Modificato	Prodotto soggetto a modifica di tipo sostanziale che, secondo la direttiva 2014/34/UE consiste in qualsiasi modifica che influisce su uno o più requisiti essenziali di sicurezza e salute (ad esempio la temperatura) o sull'integrità della protezione.	SI	APPLICABILITÀ DELLA NORMATIVA ENFORCEABILITY OF THE DIRECTIVE ANWENDBARKEIT DER RICHTLINIE
	Modified	Products which have undergone a substantial modification i.e., according to Directive 2014/34/UE, any modification affecting one or more essential health and safety requirements (for example temperature) or the integrity of a type of protection.	YES	
	Modifiziert	Erhebliche Modifizierung des Produkts. Im Sinne der Richtlinie 2014/34/UE ist dies jegliche Modifizierung, die eine oder mehrere grundlegende Gesundheits- oder Sicherheitsanforderungen (z. B. Temperatur) oder die Integrität einer Schutzart berührt.	JA	
	Riparato	Prodotti la cui funzionalità è stata ripristinata in seguito ad un difetto senza l'aggiunta di nuove caratteristiche o eventuali modifiche.	NO	
	Repaired	Products whose functionality has been restored following a defect without changing or adding any new feature.	NO	
	Repariert	Produkte, deren Funktionalität nach einem Defekt wiederhergestellt wurde, ohne dass neue Merkmale hinzugekommen sind oder irgendeine andere Modifizierung erfolgt ist.	NEIN	
	Ricambi	Prodotti destinati a sostituire un pezzo difettoso o usurato di un prodotto precedentemente immesso e/o messo in servizio sul mercato UE.	NO	
	Spare parts	Products that replace a defective or worn out part of a product previously placed and/or put into service on the EU market.	NO	
	Ersatzteil	Teil, das einen defekten oder verschlissenen Teil eines Produktes, das vorher innerhalb der EU in Verkehr gebracht oder in Betrieb genommen wurde, ersetzen soll.	NEIN	
	Ricambi Atex	Ricambi che costituiscono, secondo la direttiva 2014/34/UE un apparecchio, un dispositivo o un sistema o componente Ex.	SI	
Atex spare parts	Spare parts which, according to Directive 2014/34/UE, are an Ex equipment, device, system or component.	YES		
Atex Ersatzteil	Teil, das nach der Richtlinie 2014/34/UE ein Gerät, eine Vorrichtung, ein System oder ein Bestandteil Ex ist.	JA		

Tali informazioni devono essere lette attentamente ed applicate in modo rigoroso in quanto l'omissione, la trascuratezza e la non osservanza di tali disposizioni può essere causa di rischi per la salute e la sicurezza delle persone.

The instructions contained in this manual have to be carefully read and rigorously applied. Omission, negligence and non-observance of the instructions can jeopardize the health and safety of people.

Diese Anweisungen sind sorgfältig durchzulesen und unbedingt zu befolgen. Unterlassung, Nachlässigkeit und Nichtbeachtung der Anweisungen können zu Personenschäden führen.

Tale documentazione deve essere accuratamente conservata da personale responsabile in luogo idoneo per garantire il miglior stato di conservazione ed essere sempre consultabile con chiarezza all'occorrenza. In caso di deterioramento e/o smarrimento è opportuno richiedere direttamente al costruttore la modalità da seguire per avere copia di tale manuale.

This documentation should be kept in a safe place, in order to keep it in good condition, and should be duly consulted whenever required. In case of deterioration and/or loss, we advise you to contact the manufacturer and inquiry on the procedure as to obtain another copy of the manual.

Die Dokumentation ist sorgfältig in einem geeigneten Platz aufzubewahren, damit der beste Erhaltungszustand gewährleistet wird und damit man im Bedarfsfall in der Anweisungen nachschlagen kann. Im Falle von Beschädigung und/oder Verlust ist es notwendig, dem Hersteller nach der Sendung einer zusätzlichen Kopie zu bitten.

La Tramec s.r.l. si riserva la facoltà di apportare integrazioni e/o tutte le modifiche necessarie al manuale stesso, senza che ciò possa costituire motivo di ritenere inadeguata la presente pubblicazione.

Tramec s.r.l. reserve the right to introduce all the necessary modifications to the manual, without it meaning that this publication is inadequate or insufficient.

Die Firma Tramec s.r.l. behält sich das Recht vor, Ergänzungen oder Änderungen zu dieser Anleitung durchzuführen.

Responsabilità del costruttore

Il costruttore declina ogni responsabilità nel caso di:

leggi nazionali sulla sicurezza e sull'antifortunistica

Errata installazione, mancata o errata osservanza delle istruzioni fornite nel manuale uso e manutenzione

Difetti di alimentazione elettrica (per motoriduttori)

Modifiche e manomissioni

Operazioni condotte da parte di personale non addestrato o inadoneo

La sicurezza del riduttore dipende anche dalla scrupolosa osservanza del manuale, che deve essere fatta prima di effettuare l'installazione, la messa in opera e la manutenzione del riduttore e variatore stesso. Leggere integralmente le istruzioni d'uso e manutenzione e osservare tutte le precauzioni indicate ed in particolare occorre:

Operare sempre nei limiti di impiego del riduttore e variatore

Effettuare sempre una diligente manutenzione ordinaria

Adibire alle fasi di ispezione e manutenzione operatori addestrati allo scopo

Utilizzare esclusivamente ricambi originali e usare oli lubrificanti consigliati dal costruttore

ATTENZIONE!

Le configurazioni previste sui cataloghi tecnici dei prodotti Tramec sono le uniche ammesse, pertanto non tentare di utilizzare lo stesso in disaccordo con le indicazioni fornite.

Le istruzioni riportate in questo manuale non sostituiscono, ma compendiano gli obblighi della legislazione vigente sulle norme di sicurezza.

Responsability of the manufacturer

The manufacturer declines all responsibility in the following cases:

Use of reducers in a way contrary to national laws on safety and accident prevention

Wrong installation, failure to observe or wrong observation of the instructions provided in this use and maintenance manual

Power supply faults (for gear motors)

Modifications or tampering

Operations performed by untrained or unsuitable personnel

The safety of the reducer also depends on scrupulous observance of the manual. This must be read and fully understood before carrying out installation, commissioning and maintenance jobs on the reducer and variator. Fully read the operating and maintenance instructions and take all indicated precautions, especially:

Always work within the operating limits of the reducer and variator

Always perform diligent routine maintenance

Appoint only purposely trained workers to carry out inspections and maintenance

Only use original spare parts and lubricating oils recommended by the manufacturer.

IMPORTANT!

The configurations in the Tramec product technical catalogues are the only admissible ones. Do not attempt to use the product in ways other than in accordance with the indications provided.

The instructions shown in this manual do not replace, but integrate applicable legal obligations on safety.

Haftung des Herstellers

Der Hersteller lehnt jede Haftung in den folgenden Fällen ab:

Einsatz des Getriebes entgegen nationalen Sicherheits- und Unfallgesetzen

Unsachgemäße Installation, mangelnde oder falsche Beachtung der Anweisungen in diesem Handbuch

Stromversorgungsfehler (für Getriebemotoren)

Änderungen und Manipulationen

Vorgänge, die von nicht ausgebildetem oder ungeeignetem Personal durchgeführt werden

Die Sicherheit von Getriebe hängt auch von der gewissenhaften Einhaltung des Handbuchs ab, das vor der Installation, Inbetriebnahme und Wartung des Getriebes und des Variators selbst gelesen werden muss. Die Anweisungen für Gebrauch und Wartung müssen vollständig gelesen und alle angegebenen Vorsichtsmaßnahmen beachtet werden, insbesondere:

Stets innerhalb der Betriebseinschränkungen für Getriebe und Variator arbeiten

Stets eine sorgfältige Routinewartung durchführen

Für die Inspektion und Wartung für diesen Zweck ausgebildetes Personal beauftragen

Ausschließlich originale Ersatzteile und vom Hersteller empfohlene Schmiermittel verwenden

ACHTUNG!

Die vorgesehenen Konfigurationen in den technischen Katalogen der Tramec-Produkte sind die einzig zugelassenen. Die Produkte dürfen daher nicht in Nichtübereinstimmung mit den Angaben verwendet werden.

Die in diesem Handbuch aufgeführten Anweisungen ersetzen nicht, sondern fassen die Verpflichtungen der geltenden Rechtsvorschriften über Sicherheitsstandards zusammen.

Per un uso conforme alla classificazione secondo la direttiva ATEX 2014/34/UE, rispettare i dati tecnici indicati sulla targhetta di marcatura e la documentazione che deve essere posta nelle vicinanze dell'apparecchio.

Le procedure di trasporto, stoccaggio, manutenzione, messa in esercizio, ecc. devono essere effettuate in assenza di atmosfera esplosiva da personale specializzato e l'alimentazione elettrica del riduttore deve essere tassativamente disattivata, ponendolo in condizioni di fuori servizio, cautelandosi verso qualsiasi condizione che possa portare ad un riavvio involontario dello stesso, o comunque ad una mobilità degli organi del riduttore.

Il riduttore Tramec è destinato all'utilizzo in ambiente con pericolo di esplosione per la presenza di miscele gas-aria e polveri-aria

Il mancato rispetto delle istruzioni indicate a catalogo o utilizzo per applicazioni diverse, pongono in estinzione l'omologazione ATEX del riduttore stesso.

For use in conformity with the classification according to directive ATEX 2014/34/EC, abide by the technical details indicated on the marking plate and documentation, which must be kept in the vicinity of the appliance.

Transport, storage, maintenance, commissioning procedures, etc. must be carried out in the absence of explosive atmosphere by skilled personnel and the power supply to the reducer must be disconnected, so the machine is in out of service condition. Precautions must also be taken to make sure it cannot be accidentally started up or that any parts of the reducer can start moving.

The Tramec reducer is intended to be used in environments where there is danger of explosion due to the presence of air-gas and dust-air mixes.

Failure to comply with the instructions indicated in the catalog or use for different applications will invalidate the ATEX approval of the gearbox itself.

Bei einer Klassifizierung gemäß ATEX 2014/34/EU-Richtlinie sind die technischen Daten auf dem Typenschild und die Dokumentation, die in der Nähe des Gerätes zur Verfügung stehen muss, zu beachten.

Die Vorgänge für Transport, Lagerung, Wartung, Inbetriebnahme usw. müssen von Fachpersonal in nicht in explosionsgefährdeter Atmosphäre ausgeführt werden. Die Stromversorgung des Untersetzungsgetriebes muss unbedingt deaktiviert und jenes muss außer Betrieb sein, um sich vor einem ungewollten Neustart oder der Bewegung der Elemente des Untersetzungsgetriebes zu schützen.

Das Untersetzungsgetriebe von Tramec ist für den Gebrauch in Umgebung mit Explosionsgefahr aufgrund des Vorhandenseins von Luft-Gas-Gemischen und Stäuben vorgesehen.

Bei Nichtbeachtung der im Katalog angegebenen Hinweise oder bei sonstiger Verwendung erlischt die ATEX-Zulassung des Getriebes selbst.

L'apparecchio di gruppo II e categoria 2 può essere usato nelle zone 1, 21, 2 e 22; per categoria 3 può essere usato nelle zone 2 e 22 luogo in cui è possibile che un'atmosfera esplosiva, sotto forma di una nube di gas o polveri combustibili nell'aria, si presenti occasionalmente durante il funzionamento; impiegare il riduttore congiuntamente ad altri apparecchi solo se questi ultimi possono operare almeno nella stessa zona. Le caratteristiche della miscela esplosiva deve rispettare i dati di temperatura massima riportate in marcatura.

Nel caso di utilizzo del riduttore in atmosfera esplosiva a causa di miscela aria-polvere, la temperatura minima di innesco della nube di pulviscolo deve essere superiore al valore letto sulla targa di marcatura, moltiplicato per il coefficiente 1.5 a cui vanno poi aggiunti 75K se è presumibile una deposizione di strati di polvere inferiore a 5 mm.

The group II and category 2 appliance can be used in the zones 1, 21, 2 and 22; for category 3 appliance can be used in the zones 2 and 22 a place where the possibility occasionally exists of an explosive atmosphere, in the form of a cloud of gas or combustible dusts in the air during machine operation; only use the reducer together with other appliances if the latter can operate at least in the same areas. The characteristics of the explosive mix must comply with the max temperature details shown on the marking plate.

In case of use of the reducer in explosive atmosphere due to air-dust mix, the minimum temperature for sparking the dusty mix must be above that read on the marking plate, multiplied by the coefficient of 1.5 to which must then be added 75K if a dust deposit layer below 5 mm is expected.

Das Gerät der Gruppe II und Kategorie 2 kann in den Bereichen 1, 21, 2 und 22 eingesetzt werden, Kategorie 3 kann in den Bereichen 2 und 22 eingesetzt werden wo während des Betriebs gelegentlich eine explosionsfähige Atmosphäre in Form einer Gaswolke oder von brennbarem Staub in der Luft auftreten kann; das Untersetzungsgetriebe nur in Verbindung mit anderen Geräten verwenden, wenn diese mindestens im gleichen Bereich arbeiten können. Die Eigenschaften des explosionsfähigen Gemisches müssen den in der Kennzeichnung angegebenen Höchsttemperaturen entsprechen

Im Falle der Verwendung des Untersetzungsgetriebes in einer explosiven Atmosphäre durch Luft-Staub-Gemisch, muss die Mindestzündtemperatur der Staubwolke höher sein als der abgelesene Wert auf dem Typenschild, multipliziert mit dem Koeffizienten 1,5, dem 75K hinzugefügt wird, wenn eine Ablagerung von Staubschichten von unter 5 mm vermutet wird.

Classificazione delle massime temperature di superficie per gli apparecchi del gruppo II G Classification of maximum surface temperatures for luminaires in group II G Einstufung der maximalen Oberflächentemperaturen für Leuchten in Gruppe II G.	
Classe di temperatura Temperature class Temperaturklasse	Massima temperatura di superficie (°C) Maximum surface temperature (°C) Maximale Oberflächentemperatur (°C)
T1	450
T2	300
T3	200
T4	135
T5	100
T6	85

Informazioni sulla sicurezza in atmosfera potenzialmente esplosiva

I riduttori di velocità prodotti dalla TRAMEC sono destinati ad essere utilizzati in ambienti denominati "Atmosfere potenzialmente esplosive", ossia atmosfere che in presenza di particolari condizioni ambientali (sostanze infiammabili allo stato di gas, vapori, nebbie e polveri mescolate all'aria) e/o legate all'esercizio di impianti e apparecchiature possono diventare la sede d'innescio e propagazione di un'esplosione. Le miscele gassose di natura esplosiva oppure le concentrazioni di polveri possono provocare gravi e letali lesioni se portate a contatto con parti calde, sotto tensione e/o in movimento presenti sul riduttore.

Si raccomanda che le attività di montaggio, di messa in servizio, di manutenzione e di ispezione del riduttore vengano eseguite:

- solo da personale autorizzato e qualificato consapevole delle condizioni di pericolo nel rispetto delle norme di sicurezza
- solo dopo aver disattivato ogni possibile fonte di alimentazione al riduttore, ponendolo in condizione di "fuori servizio" e cautelandosi rispetto a qualsiasi condizione che possa portare ad un riavvio involontario dello stesso
- solo dopo essersi sincerato di essere in presenza di sicurezza ambientale, ossia in atmosfera bonificata da eventuali residui di gas e/o polveri
- solo dopo aver riportato il riduttore a condizioni ambientali, ossia ad un valore di temperatura superficiale tale da evitare presenza di superfici calde pericolose per l'ambiente e per l'operatore
- nel rispetto:
 - delle prescrizioni conformi alla direttiva ATEX 2014/34/UE
 - delle vigenti disposizioni legislative relative alla sicurezza
 - di eventuali simboli inerenti alla sicurezza indicati su etichette adesive sui riduttori e/o motori

Per l'installazione di motori elettrici e/o altri apparecchi congiunti al riduttore Tramec, attenersi alle relative disposizioni delle case costruttrici controllando che la categoria di appartenenza sia compatibile con quella del riduttore e che il dispositivo possa quindi operare nella stessa zona del riduttore.

Un'errata combinazione del riduttore con altri dispositivi non compatibili pone in estinzione l'omologazione ATEX del riduttore stesso e declina la Tramec da ogni responsabilità.

I dati tecnici e le informazioni relative alle condizioni di utilizzo dei riduttori sono indicate sulle targhette e sui rispettivi cataloghi tecnici.

Informations on safety in a potentially explosive atmosphere

TRAMEC gearboxes are intended for use in environments called "potentially explosive atmospheres", i.e. atmospheres in which the occurrence of particular ambient conditions (flammable substances in the state of gas, vapour, fog and dust mixed with air) and/or the operation of specific equipment can cause ignition and propagation of an explosion. Explosive gas mixtures or dusts concentrations can cause serious damage and lethal injuries if they get in contact with hot parts, live electrical parts and/or moving parts of the gearbox.

Be advised that mounting, starting, servicing and inspection of the gearbox have to be carried out according to the following instructions:

- only by qualified and authorized personnel, who are fully aware of the risks, and in compliance with safety standards
- only after having disabled the gearbox. Precautions should be taken in order to prevent any accidental start of the gearbox
- only after having made sure that the environment is safe, i.e. the atmosphere has been degassed from any gas / dust residues
- only after having brought the gearbox back to ambient conditions, i.e. to a surface temperature as to avoid the occurrence of hot surfaces which may be dangerous for the environment and the operator
- in compliance with:
 - ATEX Directive 2014/34/EC
 - Current safety standards
 - Safety symbols on the labels of gearboxes and/or motors

When installing electrical motors and/or other equipment to be coupled with a Tramec gearbox, follow the instructions of the equipment's manufacturer and check that the category of the equipment is compatible with that of the gearbox and that they are allowed to operate in the same zone.

The coupling of the gearbox with incompatible equipment will annul the ATEX homologation of the gearbox and Tramec will decline all responsibility.

Technical data and operation instructions concerning the gearbox are reported on plates and technical catalogues.

Sicherheit in explosionsgefährdeten Bereichen

TRAMEC Getriebe sind zur Verwendung in "explosionsfähiger Atmosphäre" bestimmt, d. h. eine Atmosphäre, die in Folge von operativen und/oder örtlichen Bedingungen (brennbare Gase, Dämpfe, Nebel und Stäube im Gemisch mit Luft) Zündquelle werden kann. Explosionsfähige gasförmige Gemische und Staubkonzentrationen können schweren und tödlichen Verletzungen verursachen, falls sie sich mit heißen, mit sich bewegenden und mit sich unter Druck befindlichen Getriebeteilen in Kontakt kommen.

Es wird empfohlen, Installation, Inbetriebnahme, Wartung und Inspektion des Getriebes wie folgt auszuführen:

- Nur von berechtigtem Fachpersonal durchführen lassen; das Fachpersonal soll über die Gefahrbedingungen unterrichtet sein und die Sicherheitsvorschriften achten
- Nur bei stillstehendem Getriebe; das Getriebe muss spannungsfrei und "außer Dienst" gestellt werden. Das Getriebe soll gegen versehentliches Einschalten abgesichert sein
- Es muss sichergestellt werden, dass keine explosionsfähige Atmosphäre vorhanden ist
- Es muss sichergestellt werden, dass die Oberflächentemperatur bis zur Raumtemperatur gesunken ist (heiße Oberflächen würden ein Gefahr für den Betreiber und die Umwelt darstellen)
- unter Einhaltung der folgenden Vorschriften:
 - ATEX-Richtlinie 2014/34/UE
 - Geltenden Sicherheitsvorschriften
 - Sicherheitshinweise auf Motor- und/oder Getriebechild

Bei der Aufstellung von Elektromotoren und/oder anderen Geräten sind zusätzlich die Anleitungen für die Installation der Motoren zu beachten. Es soll überprüft werden, dass Motor und Getriebe zu kompatibeln Kategorien gehören und dass sie in der selben Zone arbeiten dürfen.

Die Verbindung des Getriebes mit nicht-kompatibeln Geräten führt zum Aufheben der ATEX-Zulassung und zur Ablehnung jeder Haftung von Tramec zu.

Technische Angaben und Betriebshinweise sind auf den Getriebechild und in den technischen Katalogen zu finden

Conformità alle direttive

Compliance with directives

Konformität mit der Richtlinie

Secondo la "Direttiva ATEX 2014/34/UE", le atmosfere potenzialmente esplosive vengono suddivise in **Zone** in base al livello di pericolosità:

In accordance with ATEX "Directive 2014/34/EC" potentially explosive atmospheres are divided into **Zones** according to the level of dangerousness:

"ATEX-Richtlinie 2014/34/UE" gemäß werden explosionsfähige Atmosphären in **Zonen** nach Gefahrenart eingeteilt:

ZONE / ZONE / ZONE		PRESENZA DI ATMOSFERA POTENZIALMENTE ESPLOSIVA OCCURRENCE OF POTENTIALLY EXPLOSIVE ATMOSPHERE AUF TRETEN VON EXPLOSIONSFÄHIGER ATMOSPHERE	ESISTENZA PERICOLO TYPE OF DANGER GEFÄHRLICHKEIT
(G) GAS	(D) POLVERI DUST STAUB		
0	20	Costante e/o lunghi periodi Constant and/or for long periods of time Ständig und/oder langfristig	Permanente Permanent Dauernd
1	21	Occasionale Occasional Gelegentlich	Potenziale Potential Potentiell
2	22	Molto rara e/o breve durata Very rare and/or of short duration Selten und/oder kurzzeitig	Minimo Minimum Gering

e le varie categorie di apparecchi devono essere in grado di funzionare, conformemente ai parametri operativi stabiliti dal fabbricante, nel rispetto dei seguenti livelli di protezione:

The different categories of equipment must operate in compliance with the operation parameters established by the manufacturer, as well as in compliance with the following degrees of protection:

Die verschiedenen Kategorien von Geräten sollen sowohl nach den Betriebsparametern des Herstellers als auch den folgenden Schutzmaßnahmen gemäß betrieben werden:

LIVELLO DI PROTEZIONE DEGREE OF PROTECTION SCHUTZGRAD	GRUPPO / GROUP / GRUPPE		TIPO DI PROTEZIONE TYPE OF PROTECTION SCHUTZART	CONDIZIONI DI FUNZIONAMENTO OPERATING CONDITIONS BETRIEBSBEDINGUNGEN
	I	II		
	Lavori in sotterraneo Mining applications Bergwerke	Generica atmosfera esplosiva Generic explosive atmosphere Allgemeine explosionsfähige Atmosphäre		
	Categoria / Category / Kategorie			
Molto elevato Very high Sehr hoch	M1		Due mezzi di protezione indipendenti o sicurezza garantita anche qualora si manifestino due guasti indipendenti uno dall'altro Two independent means of protection or safety guaranteed also should two uncorrelated failures occur Zwei unabhängige Schutzmaßnahmen beziehungsweise auch dann sicher, wenn zwei Fehler unabhängig auftreten	Gli apparecchi restano alimentati e in funzione anche in presenza di atmosfera esplosiva Equipment is fed and operating also in the presence of explosive atmosphere Geräte bleiben bei vorhandener explosionsfähiger Atmosphäre weiter einsatzbereit und werden weiter betrieben
Molto elevato Very high Sehr hoch		1	Due mezzi di protezione indipendenti o sicurezza garantita anche qualora si manifestino due guasti indipendenti uno dall'altro Two independent means of protection or safety guaranteed also should two uncorrelated failures occur Zwei unabhängige Schutzmaßnahmen beziehungsweise auch dann sicher, wenn zwei Fehler unabhängig auftreten	Gli apparecchi restano alimentati e in funzione nelle zone 0, 1, 2 (G) e/o 20, 21, 22 (D) Equipment is fed and operating in zones 0, 1, 2 (G) and/or 20, 21, 22 (D) Geräte bleiben in den Zonen 0, 1, 2 (G) und/oder 20, 21, 22 (D) einsatzbereit und werden weiter betrieben
Elevato High Hoch	M2		Protezione adatta al funzionamento normale e a condizioni di funzionamento gravose Protection suitable for normal and problematic operating conditions Für normalen Betrieb und erschwerte Betriebsbedingungen geeignet	Agli apparecchi viene interrotta l'alimentazione di energia in presenza di atmosfera esplosiva The feed is interrupted in case of explosive atmosphere Geräte werden bei vorhandener explosionsfähiger Atmosphäre abgeschaltet

LIVELLO DI PROTEZIONE DEGREE OF PROTECTION SCHUTZGRAD	CATEGORIA / CATEGORY / KATEGORIE		TIPO DI PROTEZIONE TYPE OF PROTECTION SCHUTZART	CONDIZIONI DI FUNZIONAMENTO OPERATING CONDITIONS BETRIEBSBEDINGUNGEN
	GRUPPO / GROUP / GRUPPE			
	I	II		
	Lavori in sotterraneo Mining applications Bergwerke	Generica atmosfera esplosiva Generic explosive atmosphere Allgemeine explosionsfähige Atmosphäre		
Elevato High Hoch		2	<p>Protezione adatta al funzionamento normale e a disturbi frequenti o apparecchi in cui si tenga normalmente conto dei guasti</p> <p><i>Protection suitable for normal operation, operation with frequent troubles and for equipment where failure is normally taken into account</i></p> <p>Im normalen Betrieb und bei üblicherweise auftretenden Fehler sicher</p>	<p>Gli apparecchi restano alimentati e in funzione nelle zone 1, 2 (G) e/o, 21, 22 (D)</p> <p><i>Equipment is fed and operating in zones 1, 2 (G) and/or 21, 22 (D)</i></p> <p>Geräte bleiben in den Zonen 1, 2 (G) und/oder, 21, 22 (D) einsatzbereit und werden weiter betrieben</p>
Normale Normal Standard		3	<p>Protezione adatta al funzionamento normale</p> <p><i>Protection suitable for normal operation</i></p> <p>Im normalen Betrieb sicher</p>	<p>Gli apparecchi restano alimentati e in funzione nelle zone 2 (G) e/o 22 (D)</p> <p><i>Equipment is fed and operating in zones 2 (G) and/or 22 (D)</i></p> <p>Geräte bleiben in den Zonen 2 (G) e/o 22 (D) einsatzbereit und werden weiter betrieben</p>

Tutti i riduttori ATEX Tramec sono progettati e realizzati in conformità con i Requisiti Essenziali di Sicurezza dell'Allegato II della "Direttiva ATEX 2014/34/UE" e vengono classificati come dispositivi appartenenti al GRUPPO II, CATEGORIA 2 (G gas e D polveri) e quindi idonei a lavorare in ZONA 1 e 2 (gas) e 21 e 22 (polveri), per CATEGORIA 3 idonei a lavorare in zona 2 (gas) e 22 (polveri).

All Tramec ATEX gearboxes are designed and manufactured in compliance with the Essential Safety Requirements of Annex II of the "ATEX Directive 2014/34/EU" and are classified as devices belonging to GROUP II, CATEGORY 2 (G gas and D dust) and therefore suitable for working in ZONES 1 and 2 (gas) and 21 and 22 (dust), for CATEGORY 3 suitable for working in ZONE 2 (gas) and 22 (dust).

Alle ATEX-Getriebe von Tramec wurden in Übereinstimmung mit den grundlegenden Sicherheitsanforderungen des Anhangs II der "ATEX-Richtlinie 2014/34/EU" entwickelt und hergestellt und sind als Geräte der GRUPPE II, KATEGORIE 2(G-Gas und D-Staub) klassifiziert und daher für die Arbeit in den ZONEN 1 und 2 (Gas) und 21 und 22 (Stäube) geeignet, für die KATEGORIE 3 für die Arbeit in der ZONE 2 (Gas) und 22 (Stäube) geeignet.

Definito il Gruppo, la Categoria e la Zona di idoneità all'utilizzo del riduttore, scelta che viene operata dal costruttore, occorre definire la Classe di Temperatura da rispettare nell'impianto entro il quale il riduttore deve lavorare, scelta che deve essere attuata dal personale competente al dimensionamento dell'impianto in base alla seguente tabella:

Having defined the Group, Category and Zone of suitability for use of the gearbox, a choice which is made by the manufacturer, it is necessary to define the Temperature Class to be respected in the system within which the gearbox must work, a choice which must be made by the personnel responsible for dimensioning the system according to the following table:

Nach der Festlegung der Gruppe, der Kategorie und der Zone für die Eignung des Getriebes, die vom Hersteller vorgenommen wird, muss die Temperaturklasse festgelegt werden, die in der Anlage, in der das Getriebe arbeiten soll, einzuhalten ist; diese Auswahl muss von dem für die Dimensionierung der Anlage verantwortlichen Personal gemäß der folgenden Tabelle getroffen werden:

Classe di temperatura Temperature Class Temperaturklasse	Massima temperatura superficiale °C Maximum surface temperature °C Max. Oberflächentemperatur °C
T1	450
T2	300
T3	200
T4	135
T5	100
T6	85

La normativa definisce come massima temperatura superficiale la temperatura più elevata rilevata, durante il servizio nelle condizioni operative più gravose, da una parte o superficie dell'apparecchio, del sistema di protezione o del componente, che può produrre un'accensione dell'atmosfera potenzialmente esplosiva circostante.

NOTA 1: la massima temperatura di superficie degli apparecchi comprende il margine di sicurezza fino alla minima temperatura dell'atmosfera potenzialmente esplosiva.

NOTA 2: il rapporto tra la massima temperatura di superficie degli apparecchi e la minima temperatura di accensione degli strati di polveri e delle nubi di polvere.

NOTA 3: la massima temperatura di superficie è determinata senza depositi di polveri sugli apparecchi.

The Directive defines the Maximum Surface Temperature as the highest temperature measured under the most problematic operating conditions in a part or surface either of the equipment, or of the protective system or of the component, which can cause the ignition of the surrounding potentially explosive atmosphere.

NOTE 1: *the maximum surface temperature of the equipment includes the safety margin up to the minimum ignition temperature of the potentially explosive atmosphere*

NOTE 2: *the ratio between the maximum surface temperature of the equipment and the minimum ignition temperature of dust layers and dust clouds.*

NOTE 3: *the maximum surface temperature is determined without any deposited dust on the equipment.*

Die Richtlinie definiert die maximale Oberflächentemperatur als die höchste Temperatur, die bei Betrieb unter den ungünstigsten Bedingungen von einem Teil oder einer Oberfläche eines Gerätes, eines Schutzsystems oder einer Komponente, durch die die umgebende explosionsfähige Atmosphäre gezündet werden kann, erreicht wird.

ANMERKUNG 1: die maximale Oberflächentemperatur der Geräte berücksichtigt die Sicherheitsmarge bis zur Mindesttemperatur der explosionsfähigen Atmosphäre

ANMERKUNG 2: das Verhältnis zwischen der maximalen Oberflächentemperatur der Geräte und der Mindestzündtemperatur von Staubschichten und -wolken

ANMERKUNG 3: die maximale Oberflächentemperatur ist ohne Staubschichten auf den Geräten zu messen

Nel caso di atmosfera potenzialmente esplosiva con presenza di:

In case of potentially explosive atmosphere with presence of:

Im Falle von explosionsfähiger Atmosphäre mit:

gas	zone 1 e 2	Ci si riferisce alle classi di temperatura riportate in tabella o alla temperatura massima superficiale definita in funzione del tipo di gas presente in atmosfera e definita dalla normativa stessa
	zones 1 and 2	Reference is made either to the temperature classes reported in the table, or to the maximum surface temperature determined on the basis of the type of gas in the atmosphere and defined by the directive
	Zone 1 und 2	Bezug nehmen auf die in der Tabelle angegebenen Temperaturklasse oder auf die maximale Oberflächentemperatur (abhängig von der Art von Gas) wie es in der Richtlinie definiert wird
polveri dusts Staub	Zone 21 e 22	Occorre indicare la temperatura massima superficiale (°C) in funzione del tipo di polvere presente in atmosfera e definita dalla normativa stessa
	zones 21 and 22	It is necessary to indicate the maximum surface temperature (°C) on the basis of the type of dust in the atmosphere and defined by the directive
	Zone 21 und 22	Die maximale Oberflächentemperatur ist anzugeben (°C), die von der Art von Staub abhängt und wie es in der Richtlinie definiert wird

I riduttori Tramec ATEX serie appartenenti al GRUPPO II, CATEGORIA 2-3, appartengono alla CLASSE di temperatura T4 per 2G-3D e T130°C per 2D-3D.

Tutte le versioni di riduttore soddisfano il grado di protezione IP66 conformemente alla EN 60529.

Tramec gearboxes ATEX series classified in GROUP II, CATEGORY 2-3, belong to the temperature class T4 for 2G-3D and T130°C for 2D-3D.

All versions of Tramec gearboxes meet the IP66 degree of protection in compliance with EN 60529.

Tramec ATEX Getriebe der Serie GRUPPE II, KATEGORIE 2-3 gehören der TEMPERATURKLASSE T4 für 2G-3D und T130°C für 2D-3D.

Alle Getriebeversionen entsprechen der IP66 Schutzart gemäß EN 60529.

Limiti e condizioni di impiego

Questi riduttori sono tutti destinati ad un impiego industriale con temperatura ambiente da un minimo di -20°C ad un massimo di +40°C.

Nelle tabelle riportate nelle sezioni relative ad ogni tipologia di riduttore sono indicati i valori della massima potenza applicabile in entrata, in condizioni di **servizio continuo**, per una temperatura massima ambiente di 40 °C, in condizioni standard di ventilazione naturale per consentire l'utilizzo del riduttore nella **classe** di temperatura **Atex** indicata a catalogo.

I dati riportati nella targhetta, relativi alle massime temperature superficiali, sono riferiti a misurazioni eseguite in condizioni ambientali normali e ad una corretta installazione e prevista manutenzione. Variazioni anche minime di queste condizioni e il non rispetto delle istruzioni riportate in questo manuale possono indurre a differenti effetti sullo sviluppo del calore ponendo in estinzione l'omologazione Atex del riduttore.

I riduttori vengono forniti in varie forme costruttive e configurazioni consultabili nel "Catalogo generale Tramec" nel quale vengono riportati tutti i dati geometrici necessari.

Limits and conditions of operation

All gearboxes are intended for industrial use at an ambient temperature between a minimum of -20°C and a maximum of +40°C.

The sections relative to each type of gearbox contain tables indicating the values of the maximum applicable power at input, in conditions of **continuous duty**, at a maximum **ambient** temperature of 40°C, in standard conditions of natural ventilation, for utilization of the gearbox in the **Atex temperature class** reported in the catalogue.

The data reported on the plate concerning the maximum surface temperature refer to measurements taken under normal ambient conditions, correct installation and proper servicing. Variations, even though minimum, of these conditions and non-observance of the instructions contained in this manual may produce different effects on heat development and consequently annul the Atex homologation of the gearbox.

The gearboxes are available in various mounting positions and configurations together with a wide range of accessories, as described in the "Tramec General Catalogue", which also contains all the technical and geometrical data that are necessary for selecting the correct type of gearbox for the required application.

Betriebsbedingungen und Verwendungsbereiche

Diese Getriebe sind für den industriellen Einsatz in einer Umgebungstemperatur von min. -20°C bis max. +40°C vorgesehen.

In der folgenden Abschnitten werden für jeden Getriebetyp die Werte der am Antrieb zugelassenen maximalen Leistung (im **Dauerbetrieb, mit 40 °C** als maximale **Umgebungstemperatur**, mit normaler Lüftung) für Einsatz des Getriebes in der im Katalog angegebenen **Atex-Temperaturklasse**.

Die auf den Schild angegebene Oberflächentemperatur bezieht sich auf Temperaturmessung unter normalen Umgebungsbedingungen, korrekte Installation und Wartung. Schon kleine Änderungen dieser Verhältnisse und Nichtbeachtung dieser Anleitung können die Getriebetemperatur wesentlich beeinflussen und zur Nichtigkeitserklärung der Atex-Zulassung führen.

Die Getriebe sind in verschiedenen Einbaulagen und mit einer breiten Auswahl an Zubehör verfügbar, wie es in dem "Tramec Generalkatalog" beschrieben wird. Der Generalkatalog enthält auch alle technischen und geometrischen Daten, die für die Auswahl des richtigen Getriebes für die erforderliche Anwendung nötig sind.

I riduttori non devono essere immagazzinati in ambienti a pericolo di esplosione

Prima di utilizzare il riduttore, gli alberi d'uscita e le superfici esterne devono essere accuratamente pulite per mezzo di un solvente, dai prodotti antiossidanti

ATTENZIONE!

Il solvente non deve entrare in contatto con gli anelli di tenuta per evitare di danneggiare il materiale. Eseguire queste operazioni al di fuori di zone con pericolo di esplosioni

The reducers must not be stored in explosion-risk environments

Before using the reducer, the output shafts and outer surfaces must be carefully cleaned, removing all anti-oxidising products using a solvent.

IMPORTANT!

The solvent must not come into contact with the grommets to avoid damaging the material. Perform these operations outside explosion-risk areas

Die Getriebe dürfen nicht in explosionsgefährdeten Umgebungen gelagert werden

Vor der Verwendung der Getriebe müssen die Ausgangswellen und Außenoberflächen sorgfältig mit einem Lösungsmittel von den Antioxidationsmitteln gereinigt werden

ACHTUNG! Das Lösungsmittel darf nicht mit den Dichtungsringen in Kontakt kommen, um eine Beschädigung des Materials zu vermeiden. Diese Vorgänge sind außerhalb explosionsgefährdeter Bereiche auszuführen

Identificazione

Tutti i riduttori e motoriduttori sono identificati da una targa contenente i dati relativi alle caratteristiche costruttive e funzionali (definendo in tal modo sia i precedenti accordi contrattuali che le caratteristiche funzionali). Evitarne la rimozione o il danneggiamento in quanto i dati contenuti dovranno essere citati nell'eventuale richiesta di ricambi e per il riconoscimento di eventuali interventi in garanzia.

Identification

All reducers and gear motors have an identification plate which contains data concerning manufacturing and operation (thus defining both the foregoing contractual agreements and the features of operation). Never remove or damage this identification plate as mentioned data should always be specified when ordering spare parts and when submitting warranty claims.

Identifikation

Alle Getriebe und Getriebemotoren werden durch ein Typenschild gekennzeichnet, auf dem die Bau- und Betriebseigenschaften angegeben werden (dadurch werden sowohl die vorausgehenden vertraglich festgelegten Baueigenschaften als auch die Betriebseigenschaften festgelegt). Das Typenschild darf nicht abgenommen oder beschädigt werden, weil die darauf angegebenen Daten im Fall einer Ersatzteilanforderung und im Hinblick auf eine eventuelle Anerkennung der Garantie angegebenen werden sollen.

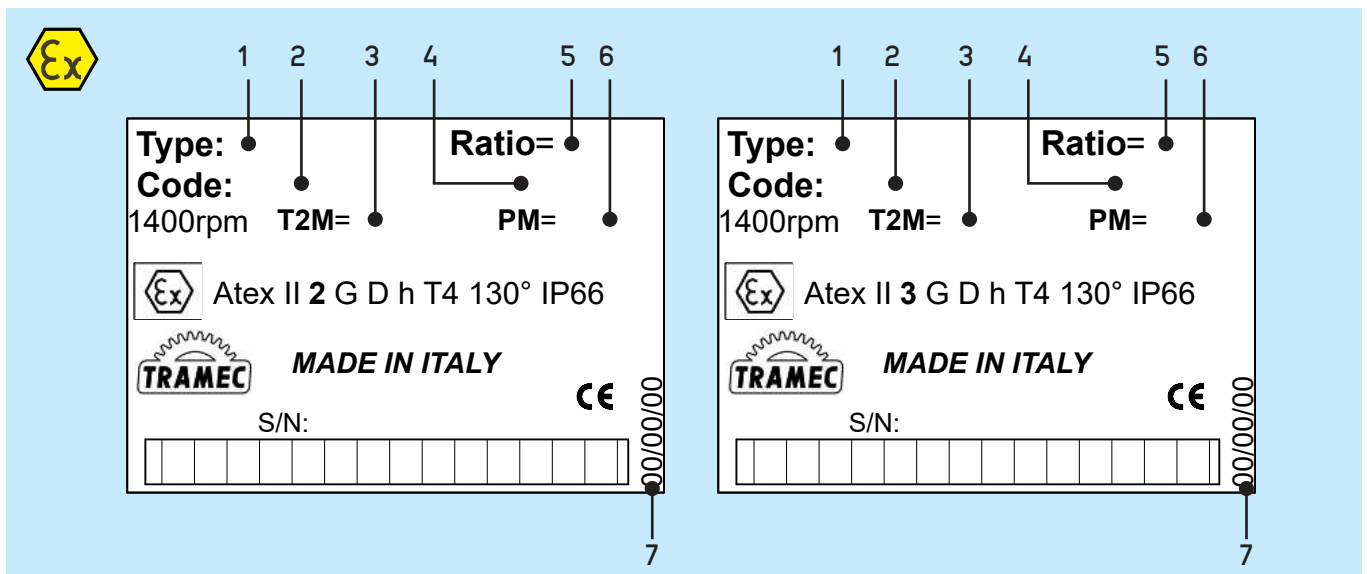

Pos.			
1	TIPO: descrizione	TYPE: description	TYP: Bezeichnung
2	CODICE: distinta base	CODE: base list	ART.-Nr.: Basisstückliste
3	T2M: coppia in uscita	T2M: output torque	T2M: Getriebe Drehmoment
4	VARIANTE: codice alfanumerico	MODEL: alphanumeric code	VARIANTE: alphanumerische Nummer
5	RAP: rapporto di riduzione	RATIO: reduction ratio	ÜBERS: Untersetzungsverhältnis
6	PM: potenza motore	PM: Motor power	PM: Motor Leistung
7	DATA: mese/anno	DATE: month/year	DATUM: Monat/Jahr

Evitarne la rimozione o il danneggiamento in quanto i dati contenuti dovranno essere citati nell'eventuale richiesta di ricambi e per il riconoscimento di eventuali interventi in garanzia. La targa identificativa deve essere sempre conservata leggibile in tutti i suoi dati attraverso una periodica pulizia.

Do not remove or damage the plate since mentioned data should be reported when ordering spare parts or when submitting warranty claims. The identification plate should be cleaned periodically in order to keep all the mentioned data legible.

Das Typenschild darf nicht abgenommen oder beschädigt werden, weil die darauf angegebenen Daten im Falle einer Ersatzteilbestellung oder im Hinblick auf eine eventuelle Anerkennung der Garantie angegeben werden sollen. Das Typenschild soll immer völlig lesbar sein und regelmäßig gereinigt werden.



ATEX 2014/34 UE
GRUPPO II cat. 2
ZONA 1 - 21

ATEX 2014/34 EU
GROUP II cat. 2
ZONE 1 - 21

ATEX 2014/34 EU
GRUPPE II Kat. 2
ZONE 1 - 21

Dati tecnici
riduttori

Technical data
of the gearboxes

Technische Daten
der Getriebe

B3



AT

RIDUTTORI AD ASSI
ORTOGONALI

BEVEL HELICAL
GEARBOX

KEGELSTIRNRADGETRIEBE

B3



AZ

RIDUTTORI AD ASSI
PARALLELI

PARALLEL SHAFT
GEARBOX

PARALLELENGETRIEBE

B8



AP

RIDUTTORI
PENDOLARI

SHAFT-MOUNTED
GEARBOX

AUFSTECKGETRIEBE

B12



AM

RIDUTTORI
PENDOLARI

SHAFT-MOUNTED
GEARBOX

AUFSTECKGETRIEBE

B14



AR

RINVII
ANGOLARI

RIGHT ANGLE
GEARBOX

WINKELGETRIEBE

B16



AL

RINVII
ANGOLARI

RIGHT ANGLE
GEARBOX

WINKELGETRIEBE

B18



AX

RIDUTTORI A VITE
SENZA FINE

WORM
GEARBOXES

SCHNECKENGETRIEBE

B20



AK

RIDUTTORI A VITE
SENZA FINE

WORM
GEARBOXES

SCHNECKENGETRIEBE

B21



AS..K

RIDUTTORI A VITE
SENZA FINE

WORM
GEARBOXES

SCHNECKENGETRIEBE

B22



AB..K

RIDUTTORI A VITE
SENZA FINE

WORM
GEARBOXES

SCHNECKENGETRIEBE

B23



AH

RIDUTTORI A VITE SENZA
FINE CON PRECOPPIA

HELICAL WORM
GEARBOXES

STIRNRAD-
SCHNECKENGETRIEBE

B26

Dati tecnici riduttori

La Tramec propone per il mercato Atex famiglie di riduttori, alla cui designazione standard riportata nel "Catalogo dei Riduttori ad Ingranaggi Ortogonali e Paralleli" viene anteposta la lettera "A" a indicazione degli accorgimenti tecnici necessari al raggiungimento della conformità alla direttiva Atex 2014/34 UE e quindi certificati a lavorare in ambiente potenzialmente esplosivo:

- riduttori ad ingranaggi cilindrici con assi ortogonali serie **AT**
- riduttori ad ingranaggi cilindrici con assi paralleli serie **AZ**
- riduttori ad ingranaggi cilindrici pendolari serie **AP** e **AM**
- rinvii angolari ad ingranaggi cilindrici serie **AR** e **AL**
- riduttori a vite senza fine serie **AX**, **AK**, **AH**, **SFK**, **SRK**, **BFK** e **BRK**

Tutte le informazioni specifiche del riduttore acquistato sono contenute e/o rintracciabili attraverso i dati riportati nella targhetta di identificazione del riduttore stesso e le tavole ricambi complete di tutte le versioni della famiglia di riduttori Atex sono disponibili e consultabili nel "Catalogo di uso e manutenzione Tramec" presente sul sito aziendale "www.Tramec.it".

Technical data of the gearboxes

Tramec offers on the Atex market series of gearboxes. Letter "A" is placed before the standard designation given in the "Tramec Helical and Bevel Helical Gearboxes Catalogue" as an indication of the technical changes the gearbox was subject to in order to make it compliant with Atex Directive 2014/34 EC and therefore certified to work in a potentially explosive environment:

- Bevel helical gearboxes **AT** serie
- Parallel shaft gearboxes **AZ** serie
- Shaft-mounted gearboxes **AP** and **AM** series
- Right angle gearboxes **AR** and **AL** serie
- Worm gearboxes **AX**, **AK**, **AH**, **SFK**, **SRK**, **BFK** and **BRK** series

Specific information pertaining the purchased gearbox are contained and/or traceable through the data reported on the identification plate; spare parts tables, complete with all Atex versions, are available and consultable in the "Tramec Use and Maintenance Manual" on the company's web site "www.Tramec.it".

Technische Daten der Getriebe

Tramec bietet auf dem Atex-Markt Serien von Getrieben. Der Buchstabe "A" wird vor der im "Tramec Untersetzungsgetriebekatalog" angegebenen Standardbezeichnung vorangesetzt, um darauf hinzuweisen, dass die Getriebe Atex-konform 2014/34 UE sind und deswegen zum Einsatz in explosionsgefährdeten Bereichen zugelassen sind:

- Kegelstirnradgetriebe Serie **AT**
- Parallelengetriebe Serie **AZ**
- Aufsteckgetriebe Serie **AP** und **AM**
- Winkelgetriebe Serie **AR** und **AL**
- Schneckengetriebe Serien **AX**, **AK**, **AH**, **SFK**, **SRK**, **BFK** und **BRK**

Spezifische Daten über das erworbene Getriebe sind auf dem Typenschild des Getriebes zu finden. Ersatzteillisten für jede Atex-Getriebeserie sind in der "Tramec Betriebs- und Wartungsanleitung" auf die Webseite "www.Tramec.it" verfügbar.

SIMBOLO SYMBOL KURZZEICHEN	DEFINIZIONE	DEFINITION	ERLÄUTERUNG	UNITA' DI MISURA UNIT OF MEASURE MAßEINHEIT
i_n	Rapporto di riduzione nominale	Nominal reduction ratio	Nennübersetzungsverhältnis	
i_r	Rapporto di riduzione reale	Actual reduction ratio	Reelles Übersetzungsverhältnis	
kW	Kilowatt	Kilowatt	Kilowatt	1 kW = 1.36 HP
IEC	Motori accoppiabili	Motor options	Passende Motoren	
n_1	Numero di giri in entrata	Revolutions at input	Drehzahl am Antrieb	rpm - giri/1' /Umdrehungen/1'
n_2	Numero di giri in uscita	Revolutions at output	Drehzahl am Abtrieb	rpm - giri/1' /Umdrehungen/1'
Nm	Newtonmetro	Newton-meter	Newtonmeter	1 Nm = 0.1 Kg
P	Potenza in entrata versione albero	Power at input shaft version	Leistung am Antrieb - Version mit Welle	kW
P₁	Potenza in entrata versione IEC	Power at input IEC version	Leistung am Antrieb - IEC Version	kW
F_{R1}	Carico radiale in entrata	Radial load at input	Querkraft am Antrieb	N
F_{R2}	Carico radiale in uscita	Radial load at output	Querkraft am Abtrieb	N
rpm	Giri al minuto	Revolutions per minute	Umdrehungen pro Minute	
T_{2M}	Coppia massima in uscita	Maximum torque at output	Max. Drehmoment am Abtrieb	kW
T₂	Coppia in uscita versione IEC	Output torque IEC version	Drehmoment am Abtrieb - IEC Version	kW

Riduttori ad assi ortogonali
serie AT









Bevel helical gearboxes
AT series

Kegelstirnradgetriebe
Serie AT

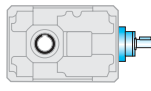
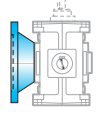
Designazione

Designation

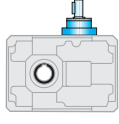
Bezeichnung

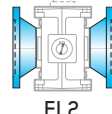
Riduttore Gearbox Getriebe	Tipo entrata Input type Antriebsart	Grandezza Size Größe	Rotismo Gearing Räderwerk	Rapporto rid. Ratio Untersetzungsverhältnis	Predisposiz. Motor coupling Motorschluss	Albero uscita cavo Hollow output shaft Abtriebshohlwelle	Entrata supplementare Additional input Zusatzantrieb	Esecuzione Execution Ausführung	Posizione di montaggio Mounting position Baulage	Flangia uscita Output flange Abtriebsflansch
AT	A	112	B	10	P.A.M.	-	S.e.A.	O	B3	FLS
Riduttore ad assi ortogonali Bevel helical gearbox Kegelstirnradgetriebe	 A	56 63 71 75 90 112 140 180 200	 B	$i_n =$ 5 : 630	56 : 225	(1)	 A	 O	B3 B6 B7 B8 VA VB	 FLS
	 C		 C				 C			 V
	 F	56 63 75 80 100 125 160					 F			 FL2

(1) Indicare il diametro dell'albero cavo solo se non è standard.
Es.: AT A 112 B 10 90 O B3 40

(1) Diameter of the hollow output shaft to be specified only if it is not standard.
Ex.: AT A 112 B 10 90 O B3 40

(1) Benennen Sie bitte den Durchmesser der Abtriebshohlwelle, insofern dieser nicht dem Standarddurchmesser entspricht
Beispiel: AT A 112 B 10 90 O B3 40

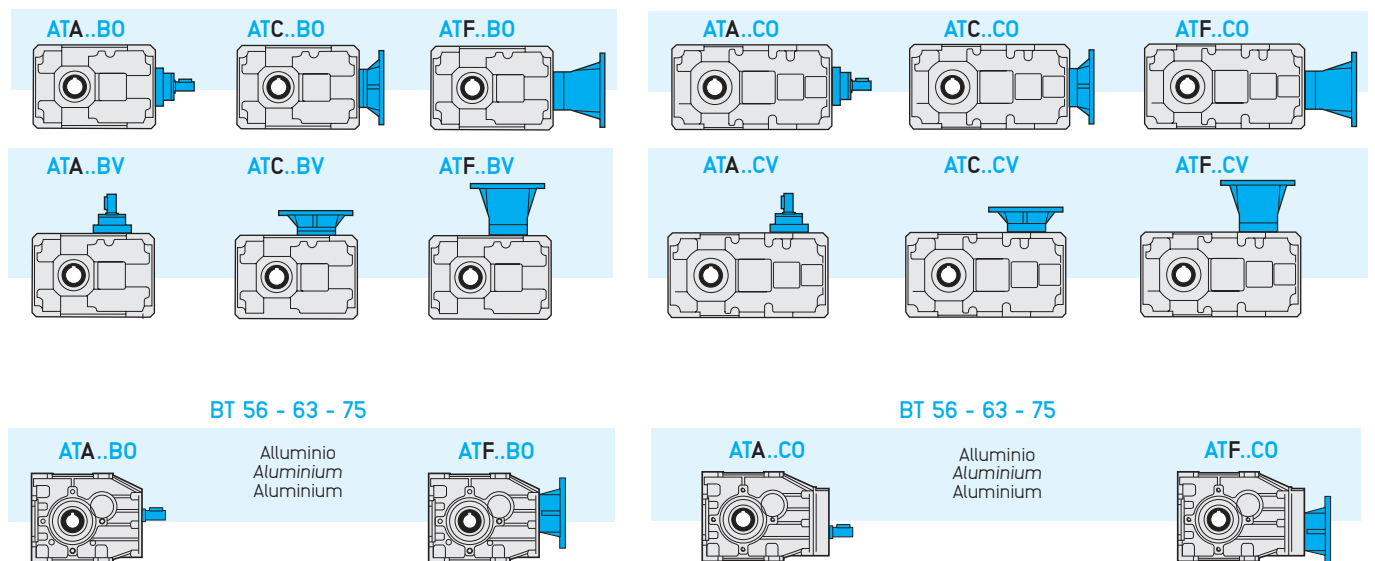

Per le dimensioni, gli accessori e le posizioni di montaggio vedere il "Catalogo dei Riduttori ad Ingranaggi Ortogonali e Paralleli".
Non sono previsti i seguenti kit:
Protezione albero cavo - Dispositivo antiretro - Albero lento cavo con calettatore - Braccio di Reazione.

For dimensions, accessories and mounting positions see the "Tramec Helical and Bevel Helical Gearboxes Catalogue".
The following kits are not available:
Hollow shaft protection kit - Backstop device - Hollow output shaft with shrink disc - Torque arm.

Informationen über Abmessungen, Ersatzteile und Montageposition sind in dem "Tramec Untersetzungsgetriebekatalog" zu finden. Die folgenden Vorrichtungen sind nicht verfügbar: Schutzvorrichtung für Hohlwelle - Rücklaufsperrung - Abtriebshohlwelle mit Schrumpfscheibe - Drehmomentstütze.

Dati tecnici

Technical data

Technische Daten

AT	n ₁ = 1400 rpm			ATA		ATF										ATF - ATA		Classe / Class / Klasse [°C]		
	i _n	i _r	n ₂ rpm	T _{2M} Nm	P kW	T ₂ Nm	P ₁ kW	F _{sa}	Input - IEC						F _{R1} N	F _{R2} N	2G	2D		
									112	100	90	80	71	63	56					
56B	8	8.06	174	73	1.40	57	1.1	1.3			B5 B14							1300	T4	130
	10	10.17	138	79	1.20	72	1.1	1.1									1300			
	12.5	12.31	114	80	1.00	72	0.9	1.1									1300			
	16	15.00	93	68	0.70	53	0.55	1.3									1800			
	20	20.33	69	79	0.60	72	0.55	1.1	-	-		B5 B14		B5	B5		1800			
	25	24.62	57	88	0.55	88	0.55	1.0			-						1800			
	31.5	30.00	47	87	0.45	72	0.37	1.2									1800			
	40	39.38	36	89	0.35	64	0.25	1.4									2300			
50	48.00	29	93	0.30	78	0.25	1.2									2300				
56C	40	40.28	35	77	0.30	64	0.25	1.2									2300	T4	130	
	50	50.83	28	97	0.30	81	0.25	1.2					B5 B14				2300			
	63	61.54	23	109	0.28	98	0.25	1.1									2300			
	80	75.00	19	116	0.24	86	0.18	1.4						B5			2800			
	100	101.67	14	116	0.18	116	0.18	1.0	-	-					B5		2800			
	125	123.08	11	116	0.15	102	0.13	1.1									2800			
	160	150.00	9	116	0.12	86	0.09	1.4									2800			
	200	196.92	7	125	0.10	112	0.09	1.1									3000			
250	240.00	6	120	0.08	91	0.06	1.3									3000				
63B	8	7.94	176	87	1.70	77	1.5	1.1			B5 B14						1500	T4	130	
	10	10.18	138	106	1.60	99	1.5	1.1									1500			
	12.5	12.50	112	122	1.50	122	1.5	1.0									1500			
	16	15.88	88	113	1.10	113	1.1	1.0									2000			
	20	20.36	69	119	0.90	119	0.9	1.0									2000			
	25	25.00	56	130	0.80	122	0.75	1.1									2000			
	31.5	31.00	45	131	0.65	110	0.55	1.2									2000			
	40	40.00	35	143	0.55	143	0.55	1.0									2500			
50	49.60	28	129	0.40	119	0.37	1.1									2500				
63	60.80	23	118	0.30	99	0.25	1.2									2500				
63C	40	39.71	35	76	0.30	63	0.25	1.2									2500	T4	130	
	50	50.89	28	97	0.30	81	0.25	1.2									2500			
	63	62.50	22	119	0.30	99	0.25	1.2						B5 B14			2500			
	80	79.41	18	151	0.30	126	0.25	1.2									3000			
	100	101.79	14	161	0.25	161	0.25	1.0	-	-					B5		3000			
	125	125.00	11	159	0.20	143	0.18	1.1									3000			
	160	155.00	9	147	0.15	128	0.13	1.2									3000			
	200	200.00	7	165	0.13	165	0.13	1.0									3500			
250	248.00	6	157	0.10	142	0.09	1.1									3500				
315	304.00	5	144	0.07	116	0.06	1.2									3500				
75B	8	7.87	178	245	4.8	204	4.0	1.2									2500	T4	130	
	10	9.82	143	279	4.4	254	4.0	1.1	B5 B14								2500			
	12.5	12.67	110	330	4.0	330	4.0	1.0									2500			
	16	15.43	91	329	3.3	299	3.0	1.1									2500			
	20	19.38	72	360	2.9	277	2.2	1.3									3000			
	25	25.00	56	356	2.2	356	2.2	1.0									3000			
	31.5	30.45	46	391	2.0	355	1.8	1.1									3000			
	40	40.00	35	371	1.4	285	1.1	1.3									3000			
50	48.73	29	378	1.2	344	1.1	1.1									3000				
75C	50	49.08	29	330	1.1	330	1.1	1.0			B5-B14						3500	T4	130	
	63	63.33	22	333	0.8	303	0.75	1.1									3500			
	80	77.15	18	352	0.70	271	0.55	1.3									3500			
	100	96.88	14	350	0.55	350	0.55	1.0									4000			
	125	125.00	11	359	0.44	299	0.37	1.2									4000			
	160	152.27	9	346	0.35	247	0.25	1.4									4000			
	200	200.00	7	380	0.30	317	0.25	1.2									4000			
	250	243.64	6	370	0.25	370	0.25	1.0									4000			

Dati tecnici

Technical data

Technische Daten

AT	n ₁ = 1400 rpm			ATA		ATC - ATF											ATC - ATF - ATA		Classe / Class / Klasse [°C]	
	i _n	i _r	n ₂	T _{2M}	P	T ₂	P ₁	F _{sa}	Input - IEC						F _{R1}	F _{R2}	2G	2D		
			rpm	Nm	kW	Nm	kW		132	112	100	90	80	71	63	N			N	
71B	10	10.25	137	120	1.80	120	1.8	1.0										3000	T4	130
	12.5	13.05	107	152	1.80	152	1.8	1.0										3150		
	16	15.63	90	182	1.80	182	1.8	1.0										3350		
	20	19.64	71	229	1.80	229	1.8	1.0				B5	B5					3550		
	25	24.99	56	219	1.35	178	1.1	1.2										3750		
	31.5	29.95	47	194	1.00	175	0.9	1.1					B14 ATC	B5	B5			4000		
	40	38.73	36	188	0.75	188	0.75	1.0										4250		
	50	50.18	28	195	0.60	179	0.55	1.1										4500		
	63	60.13	23	195	0.50	144	0.37	1.4										4750		
80	77.76	18	202	0.40	186	0.37	1.1										5000			
90B	10	10.25	137	266	4.00	266	4	1.0										4750	T4	130
	12.5	13.05	107	338	4.00	338	4	1.0										5000		
	16	15.63	90	405	4.00	405	4	1.0										5300		
	20	19.64	71	407	3.20	382	3	1.1										5600		
	25	24.99	56	486	3.00	486	3	1.0										6000		
	31.5	29.95	47	427	2.20	427	2.2	1.0										6300		
	40	38.73	36	402	1.60	376	1.5	1.1										6700		
	50	50.18	28	440	1.35	358	1.1	1.2										7100		
	63	60.13	23	429	1.10	429	1.1	1.0										7500		
80	77.76	18	403	0.80	378	0.75	1.1										8000			
80C	50	52.18	27	497	1.50	497	1.5	1.0											T4	130
	63	62.53	22	516	1.30	436	1.1	1.2												
	80	79.58	18	555	1.10	555	1.1	1.0												
	100	99.97	14	539	0.85	476	0.75	1.1												
	125	119.78	12	532	0.70	418	0.55	1.3												
	160	152.45	9	532	0.55	532	0.55	1.0												
	200	182.67	8	521	0.45	429	0.37	1.2												
	250	240.51	6	610	0.40	565	0.37	1.1												
	315	306.11	5	592	0.30	485	0.25	1.2												
	400	366.78	4	582	0.25	582	0.25	1.0												
500	474.35	3	542	0.18	542	0.18	1.0													
630	613.46	2	506	0.13	506	0.13	1.0													
112B	10	10.25	137	611	9.20	611	9.2	1.0										7500	T4	130
	12.5	13.05	107	778	9.20	778	9.2	1.0										8000		
	16	15.63	90	760	7.50	760	7.5	1.0										8500		
	20	19.64	71	827	6.50	700	5.5	1.2										9000		
	25	24.99	56	729	4.50	648	4	1.1										9500		
	31.5	29.95	47	834	4.30	776	4	1.1										10000		
	40	38.73	36	803	3.20	753	3	1.1										10600		
	50	50.18	28	813	2.50	715	2.2	1.1										10800		
	63	60.13	23	857	2.20	857	2.2	1.0										11000		
80	77.76	18	857	1.70	756	1.5	1.1										11500			
100C	50	52.18	27	927	2.80	728	2.2	1.3											T4	130
	63	62.53	22	873	2.20	873	2.2	1.0												
	80	79.58	18	1111	2.20	1111	2.2	1.0												
	100	99.97	14	1142	1.80	1142	1.8	1.0												
	125	119.78	12	1140	1.50	1140	1.5	1.0												
	160	152.45	9	1064	1.10	1064	1.1	1.0												
	200	182.67	8	927	0.80	869	0.75	1.1												
	250	240.51	6	1144	0.75	1144	0.75	1.0												
	315	306.11	5	1068	0.55	1068	0.55	1.0												
	400	366.78	4	931	0.40	861	0.37	1.1												
	500	474.35	3	903	0.30	752	0.25	1.2												
630	613.46	2	973	0.25	973	0.25	1.0													

• Flange quadrata

• Square flanges

• Viereckige Flansche

Dati tecnici

Technical data

Technische Daten

AT	n ₁ = 1400 rpm			ATA		ATC - ATF											ATC - ATF - ATA		Classe / Class / Klasse [°C]				
	i _n	i _r	n ₂ rpm	T _{2M} Nm	P kW	T ₂ Nm	P ₁ kW	F _{sa}	Input - IEC								F _{R1} N	F _{R2} N	2G	2D			
									200	180	160	132	112	100	90	80							
140B	10	10.25	137	937	14.10	731	11	1.3													11800		
	12.5	13.05	107	1192	14.10	930	11	1.3													12500		
	16	15.63	90	1317	13.00	1114	11	1.2													13200		
	18*	17.43	80	2300	20.3	2098	18.5	1.1													13600		
	20	19.64	71	1400	11.00	1400	11	1.0													14000		
	25	24.99	56	1409	8.70	1215	7.5	1.2													15000		
	31.5	29.95	47	1455	7.50	1455	7.5	1.0													16000	T4	130
	35*	33.38	42	2300	10.6	1620	7.5	1.4													16500		
	40	38.73	36	1506	6.00	1380	5.5	1.1													17000		
	50	50.18	28	1528	4.70	1301	4	1.2															
	63	60.13	23	1637	4.20	1559	4	1.1															
	70*	67.03	21	2400	5.5	2376	5.5	1.0													18000		
	80	77.76	18	1764	3.50	1512	3	1.2															
125C	50	52.18	27	1986	6.00	1821	5.5	1.1															
	63	62.53	22	1944	4.90	1587	4	1.2															
	80	79.58	18	2070	4.10	2019	4	1.0															
	100	99.97	14	1903	3.00	1903	3	1.0															
	125	119.78	12	1900	2.50	1672	2.2	1.1															
	160	152.45	9	2128	2.20	2128	2.2	1.0															
	200	182.67	8	2144	1.85	2086	1.8	1.0															
	225*	203.63	7	2580	2.00	2284	1.8	1.1															
	250	240.51	6	2136	1.40	1678	1.1	1.3															
	315	306.11	5	1748	0.90	1748	0.9	1.0															
	400	366.78	4	1978	0.85	1745	0.75	1.1															
	450*	408.87	3	2600	1.00	2350	0.9	1.1															
	500	474.35	3	2407	0.80	2257	0.75	1.1															
550*	528.78	3	2800	0.85	2562	0.75	1.1																
630	613.46	2	2530	0.65	2140	0.55	1.2																
180B	10	10.25	137	1508	22.70	1461	22	1.0															
	12.5	13.05	107	1919	22.70	1860	22	1.0															
	16	15.63	90	2026	20.00	1823	18	1.1															
	18*	17.43	80	4800	42.50	3402	30	1.4															
	20	19.64	71	2036	16.00	1909	15	1.1															
	25	24.99	56	2267	14.00	1782	11	1.3															
	31.5	29.95	47	2523	13.00	2135	11	1.2															
	35*	33.38	42	4650	21.50	3996	18.5	1.2															
	40	38.73	36	2761	11.00	2761	11	1.0															
	50	50.18	28	2439	7.50	2439	7.5	1.0															
	63	60.13	23	2922	7.50	2922	7.5	1.0															
	70*	67.03	21	4650	10.70	3975	9.2	1.2															
	80	77.76	18	3276	6.50	2772	5.5	1.2															
160C	50	52.18	27	3310	10.00	3046	9.2	1.1															
	63	62.53	22	3372	8.50	2975	7.5	1.1															
	80	79.58	18	3786	7.50	3786	7.5	1.0															
	100	99.97	14	4249	6.70	3488	5.5	1.2															
	125	119.78	12	4179	5.50	4179	5.5	1.0															
	160	152.45	9	4159	4.30	3869	4	1.1															
	200	182.67	8	4056	3.50	3476	3	1.2															
	225*	203.63	7	5800	4.50	5149	4	1.1															
	250	240.51	6	4577	3.00	4577	3	1.0															
	315	306.11	5	4272	2.20	4272	2.2	1.0															
	400	366.78	4	4421	1.90	4188	1.8	1.1															
	450*	408.87	3	5700	2.20	5747	2.2	1.0															
	500	474.35	3	3912	1.30	3310	1.1	1.2															
550*	528.78	3	5360	1.60	5124	1.5	1.1																
630	613.46	2	3892	1.00	2919	0.75	1.3																
200B	8	8.14	172	1535	29.10	1160	22	1.3															
	10	10.43	134	1967	29.10	1487	22	1.3															
	12.5	12.60	111	2376	29.10	1796	22	1.3															
	16	15.63	90	2532	25.00	2229	22	1.1															
	20	17.65	79	2688	23.50	2517	22	1.1															
	25	24.14	58	3285	21.00	2346	15	1.4															
	31.5	29.95	47	3881	20.00	2911	15	1.3															
	40	33.82	41	3945	18.00	3287	15	1.2															
	50	47.93	29	4038	13.00	3417	11	1.2															
	63	54.13	26	3858	11.00	3227	9.2	1.2															

* Rapporti speciali

* Special ratios

* Sonderverhältnisse

Dati tecnici

Technical data

Technische Daten

AT	n ₁ = 1400 rpm			ATA		ATC - ATF											ATC - ATF - ATA		Classe / Class / Klasse [°C]			
	i _n	i _r	n ₂	T _{2M}	P	T ₂	P ₁	F _{sa}	Input - IEC								F _{R1}	F _{R2}	2G	2D		
			rpm	Nm	kW	Nm	kW		200	180	160	132	112	100	90	80	N	N				
225B	8	8.44	166	2018	36.90	1641	30	1.2											36000	T4	130	
	10	10.13	138	2423	36.90	1970	30	1.2											38000			
	12.5	12.45	112	2976	36.90	2420	30	1.2											40000			
	16	15.93	88	3302	32.00	3096	30	1.1	B5 ATF	B5 ATF	B5 ATF								42400			
	20	19.13	73	3966	32.00	3718	30	1.1														44800
	25	23.49	60	4871	32.00	4566	30	1.1														47200
	31.5	30.29	46	5495	28.00	4318	22	1.3														50000
	40	37.09	38	5768	24.00	5287	22	1.1														53000
180C	50	53.11	26	5728	17.00	5054	15	1.1												T4	130	
	63	63.64	22	5652	14.00	4441	11	1.3														
	80	76.85	18	5851	12.00	5363	11	1.1			B5											
	100	99.39	14	5801	9.20	5801	9.2	1.0				B5	B5									
	125	122.88	11	5846	7.50	5846	7.5	1.0						B5	B5	B5						
	160	147.23	10	6071	6.50	5137	5.5	1.2														
	200	190.41	7	6040	5.00	4832	4	1.3														
	250	246.73	6	6104	3.90	4696	3	1.3														
	315	295.63	5	6002	3.20	5626	3	1.1														
	400	382.33	4	6306	2.60	5336	2.2	1.2														
200C	40	42.62	33	6759	25.00	5948	22	1.1												T4	130	
	50	51.18	27	8117	25.00	7143	22	1.1														
	63	62.86	22	8772	22.00	8772	22	1.0			B5											
	80	76.97	18	7812	16.00	7324	15	1.1														
	100	98.04	14	8708	14.00	6842	11	1.3														
	125	120.41	12	8403	11.00	8403	11	1.0														
	160	147.45	9	8606	9.20	8606	9.2	1.0														
	200	196.87	7	8742	7.00	6869	5.5	1.3														
	250	241.79	6	9203	6.00	8436	5.5	1.1														
	315	296.07	5	7889	4.20	7513	4	1.1														

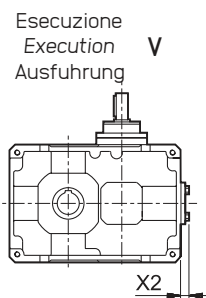
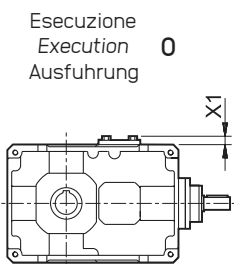

AT	X1	X2
71B - 80C	11	11
90B - 100C	14	14
112B - 125C	16	16
140B - 160C	20	20
180C	0	20
180B - 200C - 200B	21	21
225B	25	25

Designazione

Designation

Bezeichnung

Macchina Machine Maschine	Tipo entrata Input type Antriebsart	Grandezza Size Größe	Rotismo Gearing Räderwerk	Rapporto rid. Ratio Untersetzungsverhältnis	Predisposiz Motor coupling Motoranschluss	Albero uscita cavo Hollow output shaft Abtriebshohlwelle	Entrata supplementare Additional input Zusatzantrieb	Esecuzione Execution Ausführung	Posizione di montaggio Mounting position Baulage	Flangia uscita Output flange Abtriebsflansch
AZ	A	112	B	10	P.A.M.	-	S.e.A.	O	B3	FLD
Riduttore ad assi paralleli Parallel shaft gear unit Parallelengetriebe		71 90 112 140 180 225	A	$i_n =$ 5 ÷ 280	71 ÷ 200	(1)			B3 V1 V3 VA VB	
		80 100 125 160 180 200	B							
		80 100 125 160 180 200	C							

(1) Indicare il diametro dell'albero cavo solo se non è standard.
Es.: Z A 112 B 10 90 O B3 40

(1) Diameter of the hollow output shaft to be specified only if it is not standard.
Ex.: Z A 112 B 10 90 O B3 40

(1) Benennen Sie bitte den Durchmesser der Abtriebshohlwelle, insofern dieser nicht dem Standarddurchmesser entspricht
Beispiel: Z A 112 B 10 90 O B3 40

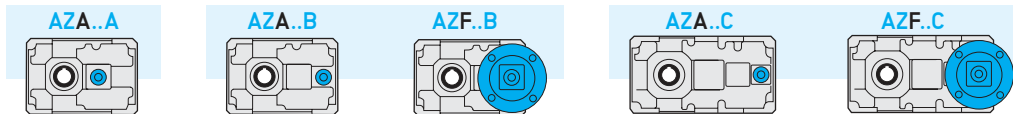

Per le dimensioni, gli accessori e le posizioni di montaggio vedere il "Catalogo dei Riduttori ad Ingranaggi Ortogonali e Paralleli".
Non sono previsti i seguenti kit:
Protezione albero cavo - Dispositivo antiretro - Albero lento cavo con calettatore - Braccio di Reazione.

For dimensions, accessories and mounting positions see the "Tramec Helical and Bevel Helical Gearboxes Catalogue".
The following kits are not available:
Hollow shaft protection kit - Backstop device - Hollow output shaft with shrink disc - Torque arm.

Informationen über Abmessungen, Ersatzteile und Montageposition sind in dem "Tramec Untersetzungsgetriebekatalog" zu finden. Die folgenden Vorrichtungen sind nicht verfügbar: Schutzvorrichtung für Hohlwelle - Rücklaufsperr - Abtriebshohlwelle mit Schrumpfscheibe - Drehmomentstütze.

Dati tecnici
Technical data
Technische Daten

AZ	$n_1 = 1400 \text{ rpm}$			AZA					
	i_n	i_r	n_2 rpm	T_{2M} Nm	P kW	F_{R1} N	F_{R2} N	Classe / Class / Klasse [°C] 2G 2D	
71A	5	5.09	275	61	1.80	400	2550	T4	130
	6.3	6.10	230	73	1.80		2700		
	8	7.89	177	90	1.72		2850		
90A	5	5.09	275	135	4.00	630	4000	T4	130
	6.3	6.1	230	161	4.00		4250		
	8	7.89	177	180	3.45		4500		
112A	5	5.09	275	310	9.20	1000	6450	T4	130
	6.3	6.10	230	371	9.20		6800		
	8	7.89	177	391	7.50		7150		
140A	5	5.09	275	741	22.00	1600	10150	T4	130
	6.3	6.10	230	888	22.00		10700		
	8	7.89	177	1050	20.12		11250		
180A	5	5.09	275	1011	30.00	2500	16400	T4	130
225A	5	4.82	291	1435	45.00	4000	34500	T4	130

Dati tecnici

Technical data

Technische Daten

AZ	n ₁ = 1400 rpm			AZA		AZF											AZF - AZA		Classe / Class / Klasse [°C]	
	i _n	i _r	n ₂ rpm	T _{2M} Nm	P kW	T ₂ Nm	P ₁ kW	F _{sa}	Input - IEC							F _{R1} N	F _{R2} N	2G	2D	
									132	112	100	90	80	71	63					
80B	10	10.20	137	119	1.80	119	1.8	1.0										4750	T4	130
	12.5	12.98	108	151	1.80	151	1.8	1.0									5000			
	16	15.56	90	181	1.80	181	1.8	1.0									5300			
	20	20.36	69	238	1.80	238	1.8	1.0									5600			
	25	24.40	57	285	1.80	285	1.8	1.0	-	-	-	B5	B5	B5	B5	400	6000			
	31.5	31.05	45	362	1.80	362	1.8	1.0									6300			
	40	37.21	38	434	1.80	434	1.8	1.0									6700			
	50	48.12	29	416	1.33	343	1.1	1.2									7100			
63	62.23	22	416	1.03	363	0.9	1.1									7500				
80C	50	52.52	27	528	1.58	500	1.5	1.1										T4	130	
	63	62.93	22	544	1.36	439	1.1	1.2												
	80	80.09	17	568	1.12	559	1.1	1.0												
	100	105.52	13	602	0.90	602	0.9	1.0												
	125	126.44	11	602	0.75	602	0.75	1.0	-	-	-	B5	B5	B5	B5	315	7500			
	160	160.92	9	561	0.55	561	0.55	1.0												
	200	208.11	7	560	0.42	488	0.37	1.1												
	250	249.36	6	585	0.37	585	0.37	1.0												
100B	10	10.20	137	264	4.00	264	4	1.0										T4	130	
	12.5	12.98	108	337	4.00	337	4	1.0									7500			
	16	15.56	90	403	4.00	403	4	1.0									8000			
	20	20.36	69	528	4.00	528	4	1.0									8500			
	25	24.40	57	632	4.00	632	4	1.0	-	B5	B5	B5	B5	B5	-	630	9000			
	31.5	31.05	45	805	4.00	805	4	1.0									9500			
	40	37.21	38	965	4.00	965	4	1.0									10000			
	50	48.12	29	848	2.72	686	2.2	1.2									10600			
63	62.23	22	848	2.10	726	1.8	1.2									11200				
100C	50	51.93	27	593	1.80	593	1.8	1.0										T4	130	
	63	62.22	23	710	1.80	710	1.8	1.0												
	80	79.19	18	904	1.80	904	1.8	1.0												
	100	103.67	14	1184	1.80	1184	1.8	1.0												
	125	124.22	11	1184	1.50	1182	1.5	1.0	-	-	-	B5	B5	B5	B5	400	11800			
	160	158.10	9	1103	1.10	1103	1.1	1.0												
	200	204.46	7	1167	0.90	1167	0.9	1.0												
	250	244.99	6	1166	0.75	1166	0.75	1.0												
125B	10	10.20	137	608	9.20	608	9.2	1.0										T4	130	
	12.5	12.98	108	774	9.20	774	9.2	1.0									11800			
	16	15.56	90	927	9.20	927	9.2	1.0									12500			
	18*	17.34	81	2450	22.0	1025	9.2	2.4									13200			
	20	20.36	69	1214	9.20	1214	9.2	1.0									13600			
	25	24.40	57	1455	9.20	1455	9.2	1.0									14000			
	31.5	31.05	45	1851	9.20	1851	9.2	1.0	B5	B5	B5	B5	B5	-	-	1000	15000			
	35*	34.62	40	2470	11.0	2076	9.2	1.2									16000			
	40	37.21	38	1880	7.80	1809	7.5	1.0									16500			
	45*	41.48	34	2400	9.00	1991	7.5	1.2									17000			
	50	48.12	29	1800	5.77	1715	5.5	1.0									17500			
	56*	53.64	26	1950	5.6	1909	5.5	1.0									18000			
	63	62.23	22	1800	4.46	1613	4.0	1.1									18500			
																				19000

* Rapporti speciali

* Special ratios

* Sonderverhältnisse

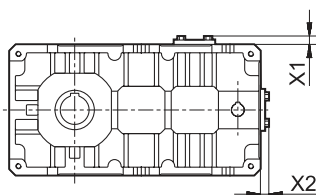

AZ	X1	X2
71A - 80B	11	11
80C	0	11
90A - 100B	14	14
100C	0	14
112A - 125B	16	16
125C	0	16
140A - 160B - 160C	0	20
180A	21	21
180B - 180C	0	20
225A	25	25
200B	21	21
200C	0	21

Designazione

Designation

Bezeichnung

Macchina Machine Maschine	Tipo entrata Input type Antriebsart	Grandezza Size Größe	Diametro albero lento Output shaft diameter Durchmesser der Abtriebswelle	Rotismo Gearing Räderwerk	Rapporto rid. Ratio Untersetzungverhältnis	Predisposiz. Motor coupling Motoranschluss	Tenditore Tensioner Spannvorrichtung	Esecuzione Execution Ausführung	Posizione di montaggio Mounting position Baulage	Flangia uscita Output flange Abtriebsflansch
AP	A	100	45	B	10/1	P.A.M.	-	0	VA	FLD
Riduttore pendolare Shaft mounted gearbox Aufsteckgetriebe	 A C	63 80 100 125 160	D_2 25 \pm 70	 A B	$i_F =$ 5 \pm 63	63 \pm 180	 TE solo only nur PA...	0	P1 P2 P3 P4 VA VB	 FLD solo only nur PC...B

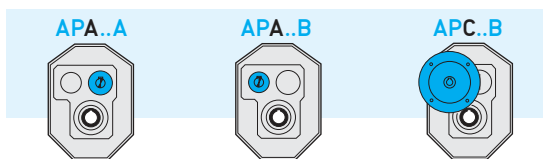

Per le dimensioni, gli accessori e le posizioni di montaggio vedere il "Catalogo dei Riduttori ad Ingranaggi Ortogonali e Paralleli".

Non sono previsti i seguenti kit:
Protezione albero cavo - Dispositivo antiretro - Albero lento cavo con calettatore - Braccio di Reazione.

For dimensions, accessories and mounting positions see the "Tramec Helical and Bevel Helical Gearboxes Catalogue".

The following kits are not available:
Hollow shaft protection kit - Backstop device - Hollow output shaft with shrink disc - Torque arm.

Informationen über Abmessungen, Ersatzteile und Montageposition sind in dem "Tramec Untersetzungsgetriebekatalog" zu finden. Die folgenden Vorrichtungen sind nicht verfügbar: Schutzvorrichtung für Hohlwelle - Rücklaufsperr - Abtriebshohlwelle mit Schrumpfscheibe - Drehmomentstütze.

Dati tecnici

Technical data

Technische Daten

AP	$n_1 = 1400 \text{ rpm}$			APA				Classe / Class / Klasse	
	i_n	i_r	n_2 rpm	T_{2M} Nm	P kW	F_{R1} N	F_{R2} N	2G	2D
63A	5	5.09	275	61	1.80	350	2040	T4	130
	6.3	6.10	230	73	1.80		2160		
	8	7.89	177	85	1.63		2280		
80A	5	5.09	275	135	4.00	400	4000	T4	130
	6.3	6.10	230	161	4.00		4250		
	8	7.89	177	170	3.26		4500		
100A	5	5.09	275	310	9.20	1000	6450	T4	130
	6.3	6.10	230	360	8.92		6800		
	8	7.89	177	340	6.51		7150		
125A	5	5.09	275	677	20.10	1600	10150	T4	130
	6.3	6.10	230	720	17.84		10700		
	8	7.89	177	680	13.03		11250		
160A	5	5.09	275	1011	30.00	2500	13120	T4	130

Dati tecnici

Technical data

Technische Daten

AP	n ₁ = 1400 rpm			APA		APC											APC - APA		Classe / Class / Klasse [°C]			
	i _n	i _r	n ₂	T _{2M}	P	T ₂	P ₁	F _{sa}	Input - IEC								F _{R1}	F _{R2}	2G	2D		
			rpm	Nm	kW	Nm	kW		180	160	132	112	100	90	80	71	63	N			N	
63B	10	10.35	135	121	1.80	121	1.8	1.0							B5	B5	B5	B5	315	1140	T4	130
	12.5	13.18	106	154	1.80	154	1.8	1.0												1340		
	16	15.79	89	184	1.80	184	1.8	1.0												1480		
	20	20.33	69	208	1.58	198	1.5	1.1												1910		
	25	25.88	54	216	1.29	184	1.1	1.2												1930		
	31.5	31.01	45	224	1.11	221	1.1	1.0												2180		
	40	40.10	35	216	0.83	195	0.75	1.1												2400		
80B	10	10.20	137	264	4.00	264	4	1.0							B5	B5	B5	B5		2800	T4	130
	12.5	12.98	108	337	4.00	337	4	1.0												3100		
	16	15.56	90	400	3.97	302	3	1.3												3450		
	20	20.36	69	416	3.15	396	3	1.1												3820		
	25	24.40	57	432	2.73	348	2.2	1.2												4200		
	31.5	31.05	45	448	2.23	443	2.2	1.0												4630		
	40	37.21	38	434	1.80	434	1.8	1.0												5100		
	50	48.12	29	416	1.33	343	1.1	1.2												5580		
63	62.23	22	400	0.99	363	0.9	1.1												6000			
100B	10	10.20	137	542	8.20	496	7.5	1.1							B5	B5	B5	B5		3250	T4	130
	12.5	12.98	108	690	8.20	631	7.5	1.1												3700		
	16	15.56	90	800	7.94	756	7.5	1.1												4220		
	20	20.36	69	832	6.30	726	5.5	1.1												4780		
	25	24.40	57	870	5.50	870	5.5	1.0												5350		
	31.5	31.05	45	896	4.45	805	4	1.1												6160		
	40	37.21	38	864	3.58	723	3	1.2												6700		
	50	48.12	29	832	2.67	686	2.2	1.2												7430		
63	62.23	22	800	1.98	726	1.8	1.1												8060			
125B	10	10.20	137	800	12.10	727	11	1.1												5150	T4	130
	12.5	12.98	108	1018	12.10	925	11	1.1												5830		
	16	15.56	90	1220	12.10	1109	11	1.1												6590		
	18*	17.34	81	2200	19.50	2072	18.5	1.1	B5											7010		
	20	20.36	69	1597	12.10	1452	11	1.1												7430		
	25	24.40	57	1739	11.00	1739	11	1.0												8280		
	31.5	31.05	45	1792	8.90	1509	7.5	1.2												9245		
	35*	34.62	40	2350	10.50	2087	9.2	1.1												9770		
	40	37.21	38	1728	7.17	1326	5.5	1.3												10300		
	45*	41.48	34	2280	8.50	2001	7.5	1.1												10840		
	50	48.12	29	1664	5.34	1247	4	1.3												11380		
	56*	53.64	26	1740	5.00	1396	4	1.2												11840		
	63	62.23	22	1613	4.00	1613	4	1.0												12310		
160B	10	10.20	137	1249	18.90	1223	18.5	1.0												9580	T4	130
	12.5	12.98	108	1590	18.90	1556	18.5	1.0												10680		
	16	15.56	90	1905	18.90	1865	18.5	1.0												11925		
	18*	17.34	81	4350	39.00	3360	30	1.3	B5											12610		
	20	20.36	69	2494	18.90	2441	18.5	1.0												13290		
	25	24.40	57	2988	18.90	2925	18.5	1.0												14680		
	31.5	31.05	45	3584	17.81	3019	15	1.2												16250		
	35*	34.62	40	4480	20.00	4196	18.5	1.1	B5											17100		
	40	37.21	38	3456	14.33	2652	11	1.3												17970		
	45*	41.48	34	4430	16.50	4003	15	1.1												18840		
	50	48.12	29	3328	10.67	2869	9.2	1.2												19720		
	56*	53.64	26	3450	9.90	3210	9.2	1.1												20480		
	63	62.23	22	3200	7.93	3025	7.5	1.1												21250		

- Flange quadrate
- * Rapporti speciali



- Square flanges
- * Special ratios

- Viereckige Flansche
- * Sonderverhältnisse

Designazione

Designation

Bezeichnung

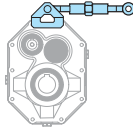
Macchina Machine Maschine	Tipo entrata Input type Antriebsart	Grandezza Size Größe	Diametro albero lento Output shaft diameter Durchmesser der Abtriebswelle	Rotismo Gearing Räderwerk	Rapporto rid. Ratio Untersetzungsverhältnis	Tenditore Tensioner Spannvorrichtung	Esecuzione Execution Ausführung	Posizione di montaggio Mounting position Baulage
AM	A	100	55	B	10/1	TE	0	P1
Riduttore pendolare Shaft mounted gearbox Aufsteckgetriebe	 A	63 80 100 125 140 160 180	D_2 35 ÷ 100	 B	$i_5 =$ 12.5 ÷ 25		0	P1 P2 P3 P4

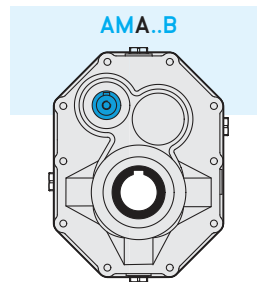

Per le dimensioni, gli accessori e le posizioni di montaggio vedere il "Catalogo dei Riduttori ad Ingranaggi Ortogonali e Paralleli".

For dimensions, accessories and mounting positions see the "Tramec Helical and Bevel Helical Gearboxes Catalogue".

Informationen über Abmessungen, Ersatzteile und Montageposition sind in dem "Tramec Untersetzungsgetriebekatalog" zu finden.

Dati tecnici
Technical data
Technische Daten

AM	$n_1 = 1400 \text{ rpm}$			AMA					
	i_n	i_r	n_2 rpm	T_{2M} Nm	P kW	F_{R1} N	F_{R2} N	Classe / Class / Klasse [°C] 2G 2D	
63B	12.5	12.83	109	200	2.40	360	-	T4	130
	16	16.01	87	232	2.25				
	20	20.66	68	248	1.85				
	25	25.17	56	264	1.60				
80B	12.5	12.91	108	376	4.50	470	-	T4	130
	16	16.55	85	464	4.30				
	20	19.99	70	496	3.80				
	25	24.80	56	516	3.20				
100B	12.5	12.91	108	611	7.30	710	-	T4	130
	16	16.55	85	783	7.30				
	20	19.99	70	946	7.30				
	25	24.80	56	977	6.00				
125B	12.5	12.90	109	878	10.5	1040	-	T4	130
	16	16.53	85	1125	10.5				
	20	19.97	70	1359	10.5				
	25	24.78	56	1686	10.5				
140B	12.5	12.91	108	1155	13.8	1400	-	T4	130
	16	16.55	85	1480	13.8				
	20	19.99	70	1788	13.8				
	25	24.80	56	2218	13.8				
160B	12.5	13.38	105	1673	19.3	1940	-	T4	130
	16	17.13	82	2142	19.3				
	20	20.67	68	2585	19.3				
	25	25.62	55	3204	19.3				
180B	12.5	13.15	106	2318	27.2	2200	-	T4	130
	16	16.86	83	2972	27.2				
	20	20.37	69	3591	27.2				
	25	25.27	55	4454	27.2				

Designazione

Designation

Bezeichnung

Macchina Machine Maschine	Tipo entrata Input type Antriebsart	Grandezza Size Größe	Rotismo Gearing Räderwerk	Tipo uscita Output type Ausgang Typ	Rapporto rid. Ratio Untersetzungsverhältnis	Predisposizione att. mot. Motor coupling Motoranschluss	Entrata supplementare Additional input Zusatzantrieb	Rotazione alberi Shafts rotation Wellendrehrichtungen	Posizione di montaggio Mounting position Baulage	Flangia uscita Output flange Abtriebsflansch
AR	A	28	A	S	10	P.A.M.	S.e.A.	B	B3	FLD
Rinvii angolari Right angle gearboxes Winkelgetriebe	A C F	19 24 28 38 48	A	S B C	$i_n =$ 1 2.5 5 10	63 ÷ 200	A C F	A B C D E F G H I L	B3 B6 B7 B8 VA VB	FLS FLD FL2

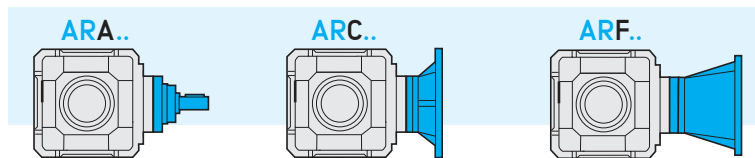

Per le dimensioni, gli accessori e le posizioni di montaggio vedere il "Catalogo dei Riduttori ad Ingranaggi Ortogonali e Paralleli".

For dimensions, accessories and mounting positions see the "Tramec Helical and Bevel Helical Gearboxes Catalogue".

Informationen über Abmessungen, Ersatzteile und Montageposition sind in dem "Tramec Untersetzungsgetriebekatalog" zu finden.

Dati tecnici
Technical data
Technische Daten

AR	n ₁ = 1400 rpm			ARA		ARC - ARF										ARC - ARF - ARA			Classe / Class / Klasse				
	i _n	i _r	n ₂	T _{2M}	P	T ₂	P ₁	F _{sa}	Input - IEC										F _{R1}	F _{R2[D2]}	F _{R2[D3]}	[°C]	
			rpm	Nm	kW	Nm	kW		180	160	132	112	100	90	80	71	63	N	N	N	2G	2D	
19	1	1	1400	12	1.80	12	1.8	1.0	-	-	-	-	-	B5	B5	B5	B5	400	800	800	T4	130	
	2.5	2.56	546	25	1.50	25	1.5	1.0	-	-	-	-	-	B5	B14	B5	B5	400	1000	630			
	5	4.91	285	24	0.75	24	0.75	1.0	-	-	-	-	-	-	-	-	-	400	1250	800			
	10	9.86	142	24	0.37	24	0.37	1.0	-	-	-	-	-	-	-	-	-	400	1600	1000			
24	1	1	1400	26	4.00	26	4	1.0	-	-	-	-	-	B5	B5	B5	-	630	1250	1250	T4	130	
	2.5	2.56	546	51	3.00	51	3	1.0	-	-	-	-	-	B5	B14	B5	B5	630	1600	1000			
	5	4.91	285	49	1.50	49	1.5	1.0	-	-	-	-	-	-	-	-	-	630	2000	1250			
	10	9.86	142	49	0.75	49	0.75	1.0	-	-	-	-	-	-	-	-	-	630	2500	1600			
28	1	1	1400	61	9.20	61	9.2	1.0	-	-	B5	B5	B5	B5	B5	-	-	1000	2000	2000	T4	130	
	2.5	2.56	546	93	5.50	93	5.5	1.0	-	-	B5	B5	B5	B5	B5	-	-	1000	2500	1600			
	5	4.91	285	97	3.00	97	3	1.0	-	-	-	-	-	-	-	-	-	1000	3150	2000			
	10	9.86	142	98	1.50	98	1.5	1.0	-	-	-	-	-	-	-	-	-	1000	4000	2500			
38	1	1	1400	94	14.20	73	11	1.3	-	B5	B5	B5	B5	B5	B5	-	-	1600	3150	3150	T4	130	
	2.5	2.56	546	187	11.00	187	11	1.0	-	B5	B5	B5	B5	B5	B5	-	-	1600	4000	2500			
	5	4.91	285	179	5.50	179	5.5	1.0	-	-	-	-	-	-	-	-	-	1600	5000	3150			
	10	9.86	142	196	3.00	196	3	1.0	-	-	-	-	-	-	-	-	-	1600	6300	4000			
48	1	1	1400	137	20.70	122	18.5	1.1	B5	B5	B5	B5	B5	-	-	-	-	2500	5000	5000	T4	130	
	2.5	2.56	546	351	20.70	314	18.5	1.1	B5	B5	B5	B5	B5	-	-	-	-	2500	6300	4000			
	5	4.91	285	357	11.00	357	11	1.0	-	-	-	-	-	-	-	-	-	2500	8000	5000			
	10	9.86	142	359	5.50	359	5.5	1.0	-	-	-	-	-	-	-	-	-	2500	10000	6300			

• Flange quadrate

• Square flanges

• Viereckige Flansche

Designazione

Designation

Bezeichnung

Macchina Machine Maschine	Tipo entrata Input type Antriebsart	Grandezza Size Größe	Rotismo Gearing Räderwerk	Tipo uscita Output type Ausgang Typ	Rapporto rid. Ratio Untersetzungsverhältnis	Predisposizione att. mot. Motor coupling Motorschluss	Entrata supplementare Additional input Zusatzantrieb	Rotazione alberi Shafts rotation Wellendrehrichtungen	Posizione di montaggio Mounting position Baulage	Flangia uscita Output flange Abtriebsflansch
AL	A	28	A	C	2	P.A.M.	S.e.A.	B	B3	FLD
Rinvii angolari Right angle gearboxes Winkelgetriebe	A C F	19 24 28 38 48	A	S B C	$i_n =$ 1 2 3	63 ÷ 200	A C F	A B C D E F	B3 B6 B7 B8 VA VB	FLS FLD FL2

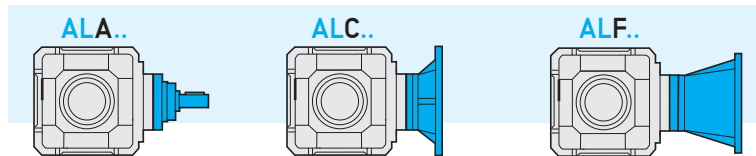

Per le dimensioni, gli accessori e le posizioni di montaggio vedere il "Catalogo dei Riduttori ad Ingranaggi Ortogonali e Paralleli".

For dimensions, accessories and mounting positions see the "Tramec Helical and Bevel Helical Gearboxes Catalogue".

Informationen über Abmessungen, Ersatzteile und Montageposition sind in dem "Tramec Untersetzungsgetriebekatalog" zu finden.

Dati tecnici
Technical data
Technische Daten

AL	n ₁ = 1400 rpm			ALA		ALC - ALF										ALC - ALF - ALA		Classe / Class / Klasse [°C] 2G 2D						
	i _n	i _r	n ₂	T _{2M}	P	T ₂	P ₁	F _{sa}	Input - IEC							F _{R1}	F _{R2}							
			rpm	Nm	kW	Nm	kW		180	160	132	112	100	90	80	71	63	N	N					
19	1	1	1400	12	1.8	12	1.8	1.0	-	-	-	-	-	B5	B5 B14	B5	B5	400	800	T4	130			
	2	2	700	40	2	40	1.5	1.0	-	-	-	-	-	-	-	-	-	1000						
	3	3	467	38	0.8	38	1.5	1.0	-	-	-	-	-	-	-	-	-	-	-			-	-	-
24	1	1	1400	26	4.0	26	4	1.0	-	-	-	-	B5	B5 B14 ALC	B5	B5	-	630	1250	T4	130			
	2	2	700	51	3	51	3	1.0	-	-	-	-	-	-	-	-	-	-	1600					
	3	3	467	65	2.2	65	2.2	1.0	-	-	-	-	-	-	-	-	-	-	-			-	-	-
28	1	1	1400	61	9.2	61	9.2	1.0	-	-	B5	B5	B5	B5	B5	-	-	1000	2000	T4	130			
	2	2	700	90	5.5	90	5.5	1.0	-	-	-	-	-	-	-	-	-	-	2500					
	3	3	467	95	3.0	95	3	1.0	-	-	-	-	-	-	-	-	-	-	-			-	-	-
38	1	1	1400	94	14.2	73	11	1.3	-	B5	B5	B5	B5	B5	-	-	-	1600	3150	T4	130			
	2	2	700	187	11	187	11	1.0	-	-	-	-	-	-	-	-	-	-	4000					
	3	3	467	175	5.5	175	5.5	1.0	-	-	-	-	-	-	-	-	-	-	-			-	-	-
48	1	1	1400	137	20.7	122	18.5	1.1	B5	B5	B5	B5	B5	-	-	-	-	2500	5000	T4	130			
	2	2	700	351	20.7	314	18.5	1.1	-	-	-	-	-	-	-	-	-	-	-			-	-	-
	3	3	467	347	11.0	347	11	1.0	-	-	-	-	-	-	-	-	-	-	-			-	-	-

• Flange quadrate

• Square flanges

• Viereckige Flansche

Riduttori a vite
senza fine AX







Worm gearboxes
AX

Schneckengetriebe
AX

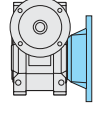
Designazione

Designation

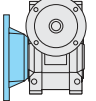
Bezeichnung

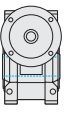
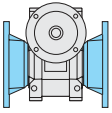
Riduttore Gearbox Getriebe	Tipo entrata Input type Antriebsart	Grandezza Size Größe	Rapporto rid. Ratio Untersetzung	Predispos.att. mot. Motor coupling Motoranschluss	Albero uscita cavo Hollow output shaft Abtriebshohlwelle	Flangia in uscita. Output flange Abtriebsflansch	Seconda entrata Additional input Zusatzantrieb	Posizione di mont. Mounting position Einbaulage
AX	A	50	10/1	P.A.M	H25	F1S	SeA	B3
Riduttore a vite senza fine Wormgearbox Schneckengetriebe	 A	30 40 50 63 75 89*	5 7.5 10 15 20 25 30 40 50 65 80 100	56 63 71 80 90 100 112 132	vedi tabelle see tables siehe Tabellen	 F1D-F2D-F3D	 SeA	B3, B6 B7, B8 V5, V6
	 C	 Alluminio Aluminium Aluminium				 F1S-F2S-F3S		
	 F	90 110 130  Ghisa Cast iron Gusseisen				 F12-F22-F32		

Tipo entrata

Input type

Antriebstyp

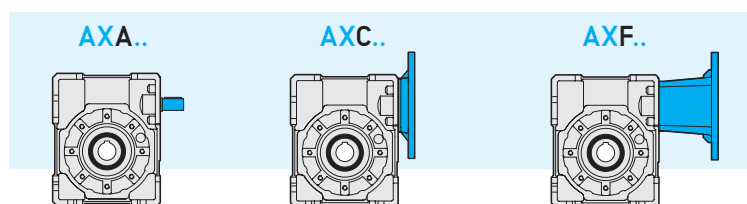

Per le dimensioni, gli accessori e le posizioni di montaggio vedere il "Catalogo dei Riduttori a Vite Senza Fine Tramec".
Non sono previsti i seguenti kit:
Protezione albero cavo - Braccio di Reazione - Limitatore di coppia.

For dimensions, accessories and mounting positions see the "Tramec Worm Gearboxes Catalogue".
The following kits are not available:
Hollow shaft protection kit - Torque arm - Torque limiter.

Informationen über Abmessungen, Ersatzteile und Montageposition sind in dem "Tramec Schneckengetriebekatalog" zu finden. Die folgenden Vorrichtungen sind nicht verfügbar: Schutzvorrichtung für Hohlwelle - Drehmomentstütze - Drehmomentbegrenzer.

Riduttori a vite
senza fine AK

Worm gearboxes
AK

Schneckengetriebe
AK

Designazione

Designation

Bezeichnung

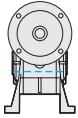
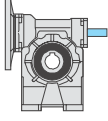
Riduttore Gearbox Getriebe	Tipo entrata Input type Antriebsart	Grandezza Size Größe	Versione Version Ausführung	Rapporto rid. Ratio Untersetzung	Predispos.att. mot. Motor coupling Motoranschluss	Albero uscita cavo Hollow output shaft Abtriebshohlwelle	Flangia uscita Output flange Abtriebsflansch	Seconda entrata Additional input Zusatzantrieb	Posizione di mont. Mounting position Einbaulage
AK	C	50	A1	10	P.A.M	H25	F1S	SeA	B3
Riduttore a vite senza fine Wormgearbox Schneckengetriebe		30 40 50 63 75 89 90 110 130	A1-A2 B1-B2 V1-V2 P	5 7.5 10 15 20 25 30 40 50 65 80 100	56 63 71 80 90 100 112 132	vedi tabelle see tables siehe Tabellen 	F1S-F2S F3S F1D-F2D F3D	 SeA	B3 B6 B7 B8 V5 V6
		Aluminio Aluminium Aluminiumium							
		Ghisa Cast iron Gusseisen							

Versioni

Versions

Ausführungen

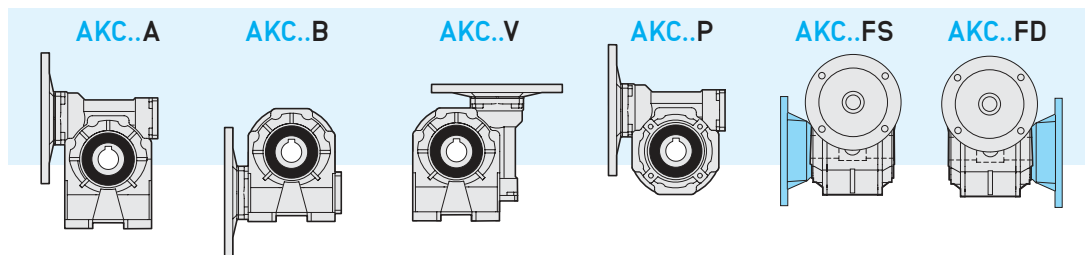

Per le dimensioni, gli accessori e le posizioni di montaggio vedere il "Catalogo dei Riduttori a Vite Senza Fine Tramec".

Non sono previsti i seguenti kit:
Protezione albero cavo - Braccio di Reazione - Limitatore di coppia.

For dimensions, accessories and mounting positions see the "Tramec Worm Gearboxes Catalogue".

The following kits are not available:
Hollow shaft protection kit - Torque arm - Torque limiter.

Informationen über Abmessungen, Ersatzteile und Montageposition sind in dem "Tramec Schneckengetriebekatalog" zu finden. Die folgenden Vorrichtungen sind nicht verfügbar: Schutzvorrichtung für Hohlwelle - Drehmomentstütze - Drehmomentbegrenzer.

Designazione

Designation

Bezeichnung

Riduttore Gearbox Getriebe	Grandezza Size Größe	Versione Version Ausführung	Flangia uscita Output flange Abtriebsflansch	Rapporto rid. Ratio Untersetzung	Predispos.att. mot. Motor coupling Motoranschluss	Albero uscita cavo Hollow output shaft Abtriebshohlwelle	Limitatore di coppia. Torque limiter Drehmoment- begrenzer	Seconda entrata Additional input Zusatzantrieb	Posizione di mont. Mounting position Einbaulage
ASFK	50	A	F1S	10	80 B14	H25	LD	SeA	B3
 ASFK ASRK	30 40 50 63 75	A B V P	F...S F...D	5 7.5 10 15 20 25 30 40 50 65 80 100	56 ÷ 112 B5 56 ÷ 112 B14	vedi tabelle see tables siehe Tabellen 	 LD LD	 SeA SeA	B3 B6 B7 B8 V5 V6

Versioni

Versions

Ausführungen

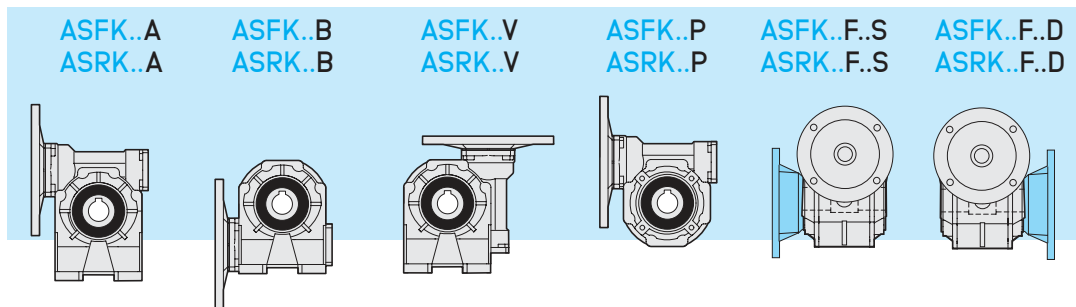

Per le dimensioni, gli accessori e le posizioni di montaggio vedere il "Catalogo dei Riduttori a Vite Senza Fine Tramec".

Non sono previsti i seguenti kit:
Protezione albero cavo - Braccio di Reazione - Limitatore di coppia.

For dimensions, accessories and mounting positions see the "Tramec Worm Gearboxes Catalogue".

The following kits are not available:
Hollow shaft protection kit - Torque arm - Torque limiter.

Informationen über Abmessungen, Ersatzteile und Montageposition sind in dem "Tramec Schneckengetriebekatalog" zu finden. Die folgenden Vorrichtungen sind nicht verfügbar: Schutzvorrichtung für Hohlwelle - Drehmomentstütze - Drehmomentbegrenzer.

Riduttori a vite
senza fine ABFK - ABRK

Worm gearboxes
ABFK - ABRK

Schneckengetriebe
ABFK - ABRK

Designazione

Designation

Bezeichnung

Riduttore Gearbox Getriebe	Grandezza Size Größe	Versione Version Ausführung	Flangia uscita Output flange Abtriebsflansch	Rapporto rid. Ratio Untersetzung	Predispos.att. mot. Motor coupling Motoranschluss	Albero uscita cavo Hollow output shaft Abtriebshohlwelle	Limitatore di coppia Torque limiter Drehmoment- begrenzer	Seconda entrata Additional input Zusatzeintrieb	Posizione di mont. Mounting position Einbaulage
ABFK	50	A	F1S	10	80 B14	H25	LD	SeA	B3
 ABFK ABRK	30 40 50 63 75	A B V P	F...S F...D	5 7.5 10 15 20 25 30 40 50 65 80 100	56 ÷ 112 B5 56 ÷ 112 B14	vedi tabelle see tables siehe Tabellen 	 LS LD	 SeA	B3 B6 B7 B8 V5 V6

Versioni

Versions

Ausführungen

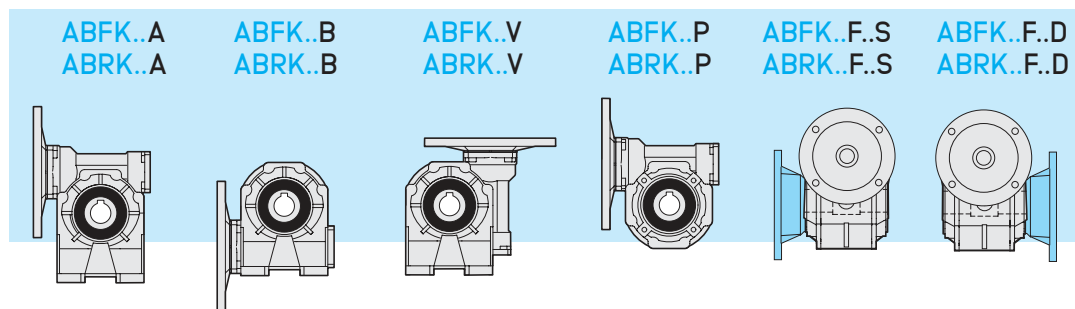

Per le dimensioni, gli accessori e le posizioni di montaggio vedere il "Catalogo dei Riduttori a Vite Senza Fine Tramec".

Non sono previsti i seguenti kit:
Protezione albero cavo - Braccio di Reazione - Limitatore di coppia.

For dimensions, accessories and mounting positions see the "Tramec Worm Gearboxes Catalogue".

The following kits are not available:
Hollow shaft protection kit - Torque arm - Torque limiter.

Informationen über Abmessungen, Ersatzteile und Montageposition sind in dem "Tramec Schneckengetriebekatalog" zu finden. Die folgenden Vorrichtungen sind nicht verfügbar: Schutzvorrichtung für Hohlwelle - Drehmomentstütze - Drehmomentbegrenzer.

Dati tecnici

Technical data







Technische Daten

AX AK AS..K AB..K	$n_1 = 1400 \text{ rpm}$			AXA ASRK ABRK		AXC - AKC - AXF ASFK - ABFK								AXA - AXC - AKC - AXF ASFK - ASRK - ABFK - ABRK				
	i_n	R_d	n_2 rpm	T_{2M} Nm	P kW	T_2 Nm	P_1 kW	F_{sa}	Input - IEC						F_{R1} N	F_{R2} N	Classe / Class / Klasse [°C]	
									100	90	80	71	63	56			2G	2D
89	15	0.84	93	172	2.00	155	1.8	1.1	-	-	B5 B14	-	850	2500	T4	130		
	20	0.82	70	201	1.80	201	1.8	1.0						2700				
	25	0.80	56	218	1.60	205	1.5	1.1						3500				
	30	0.76	47	218	1.40	171	1.1	1.3						3700				
	40	0.72	35	236	1.20	216	1.1	1.1						3900				
	50	0.69	28	259	1.10	259	1.1	1.0						4300				
	65	0.65	22	259	0.90	259	0.9	1.0						5000				
	80	0.63	18	275	0.80	258	0.75	1.1						5500				
90	15	0.84	93	172	2.00	155	1.8	1.1	-	-	B5 B14	-	850	2500	T4	130		
	20	0.82	70	201	1.80	201	1.8	1.0						2700				
	25	0.80	56	218	1.60	205	1.5	1.1						3500				
	30	0.76	47	218	1.40	171	1.1	1.3						3700				
	40	0.72	35	236	1.20	216	1.1	1.1						3900				
	50	0.69	28	259	1.10	259	1.1	1.0						4300				
	65	0.65	22	259	0.90	259	0.9	1.0						5000				
	80	0.63	18	275	0.80	258	0.75	1.1						5500				
110	15	0.84	93	258	3.00	258	3.0	1.1	-	B5 B14 (no AXF B14)	-	1200	3600	T4	130			
	20	0.83	70	317	2.80	249	2.2	1.3					4500					
	25	0.81	56	345	2.50	344	2.2	1.1					5000					
	30	0.77	47	331	2.10	284	1.8	1.2					5400					
	40	0.74	35	363	1.80	363	1.8	1.0					6300					
	50	0.72	28	417	1.70	368	1.5	1.1					6900					
	65	0.68	22	452	1.50	452	1.5	1.0					7500					
	80	0.65	18	426	1.40	390	1.1	1.1					8000					
130	15	0.85	93	358	4.10	349	4.0	1.0	B5 - B14 (no AXF B14)	B5 B14 (no AXF B14)	B5 (AXF)	-	1500	4700	T4	130		
	20	0.84	70	435	3.80	344	3.0	1.3						5000				
	25	0.83	56	524	3.70	425	3.0	1.2						6500				
	30	0.79	47	482	3.00	482	3.0	1.0						6500				
	40	0.76	35	539	2.60	456	2.2	1.2						7000				
	50	0.74	28	606	2.40	555	2.2	1.1						8000				
	65	0.71	22	647	2.10	555	1.8	1.2						8800				
	80	0.68	18	685	1.90	649	1.8	1.1						9500				

Designazione

Designation

Bezeichnung

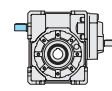
Riduttore Gearbox Getriebe	Tipo entrata Input type Antriebsart	Grandezza Size Größe	Rapporto rid. Ratio Untersetzung	Predispos.att. mot. Motor coupling Motoranschluss	Albero uscita cavo Hollow output shaft Abtriebshohlwelle	Flangia in uscita. Output flange Abtriebsflansch	Seconda entrata Additional input Zusatzantrieb	Posizione di mont. Mounting position Einbaulage
AH	A	50	30/1	P.A.M	H25	F1S	SeA	B3
Riduttore a vite senza fine Wormgearbox Schneckengetriebe	 A  F	40 50 63 75 90 110 130	30 40 60 80 100 120 160 200 260 320 400	56 63 71 80 90 100 112	vedi tabelle see tables siehe Tabellen 	 F1D-F2D-F3D  F1S-F2S-F3S  F12-F22-F32	 SeA	B3, B6 B7, B8 V5, V6

Tipo entrata

Input type

Antriebstyp

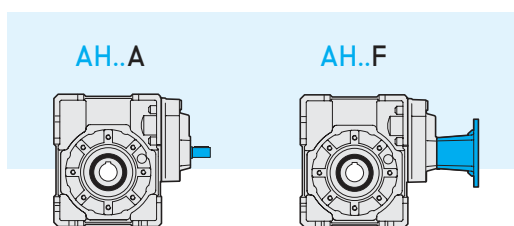

Per le dimensioni, gli accessori e le posizioni di montaggio vedere il "Catalogo dei Riduttori a Vite Senza Fine Tramec".
Non sono previsti i seguenti kit:
Protezione albero cavo - Braccio di Reazione - Limitatore di coppia.

For dimensions, accessories and mounting positions see the "Tramec Worm Gearboxes Catalogue".
The following kits are not available:
Hollow shaft protection kit - Torque arm - Torque limiter.

Informationen über Abmessungen, Ersatzteile und Montageposition sind in dem "Tramec Schneckengetriebekatalog" zu finden. Die folgenden Vorrichtungen sind nicht verfügbar: Schutzvorrichtung für Hohlwelle - Drehmomentstütze - Drehmomentbegrenzer.

Dati tecnici

Technical data

Technische Daten

AH	n ₁ = 1400 rpm			AHA		AHF										AHF - AHA		Classe / Class / Klasse [°C]	
	i _n	R _d	n ₂ rpm	T _{2M} Nm	P kW	T ₂ Nm	P ₁ kW	F _{sa}	Input - IEC						F _{R1} N	F _{R2} N	2G	2D	
									112	100	90	80	71	63	56				
40	30	0.77	47	35	0.22	35	0.22	1.0									1500	T4	130
	40	0.75	35	45	0.22	45	0.22	1.0						B5			1700		
	60	0.69	23	45	0.16	37	0.13	1.2									1800		
	80	0.66	18	40	0.11	40	0.11	1.0									1900		
	100	0.61	14	37	0.09	37	0.09	1.0									2000		
	120	0.57	12	42	0.09	42	0.09	1.0									2500		
	160	0.52	9	40	0.07	34	0.06	1.2									2500		
	200	0.47	7	38	0.06	38	0.06	1.0									2500		
50	30	0.79	47	89	0.55	89	0.55	1.0						B5			2000	T4	130
	40	0.76	35	87	0.42	77	0.37	1.1						B5			2300		
	60	0.71	23	87	0.30	73	0.25	1.2									2700		
	80	0.68	18	86	0.23	82	0.22	1.0									2900		
	100	0.63	14	73	0.17	56	0.13	1.3									2900		
	120	0.59	12	87	0.18	87	0.18	1.0									3000		
	160	0.55	9	84	0.14	78	0.13	1.1									3500		
	200	0.50	7	75	0.11	75	0.11	1.0									3500		
	260	0.46	5	73	0.09	73	0.09	1.0									3500		
	320	0.42	4	64	0.07	55	0.06	1.2									3500		
63	30	0.79	47	146	0.90	146	0.9	1.0						B5			2500	T4	130
	40	0.77	35	162	0.77	158	0.75	1.0						B5			2700		
	60	0.72	23	162	0.55	162	0.55	1.0									3500		
	80	0.70	18	153	0.40	141	0.37	1.1									4500		
	100	0.67	14	128	0.28	114	0.25	1.1									5000		
	120	0.61	12	155	0.31	125	0.25	1.2									5000		
	160	0.57	9	174	0.28	156	0.25	1.1									5000		
	200	0.52	7	142	0.20	128	0.18	1.1									5000		
	260	0.48	5	136	0.16	111	0.13	1.2									5000		
	320	0.46	4	131	0.13	131	0.13	1.0									5000		
75	30	0.80	47	252	1.54	246	1.5	1.0						B5			3200	T4	130
	40	0.78	35	266	1.25	234	1.1	1.1						B5			3400		
	60	0.73	23	281	0.94	269	0.9	1.0									4350		
	80	0.71	18	294	0.76	291	0.75	1.0									5000		
	100	0.68	14	260	0.56	255	0.55	1.0									5750		
	120	0.62	12	279	0.55	279	0.55	1.0									5750		
	160	0.58	9	266	0.42	234	0.37	1.1									5750		
	200	0.55	7	278	0.37	278	0.37	1.0									5750		
90	30	0.81	47	298	1.80	298	1.8	1.0						B5			5000	T4	130
	40	0.79	35	345	1.60	323	1.5	1.1						B5			5100		
	60	0.75	23	460	1.50	460	1.5	1.0									5500		
	80	0.72	18	471	1.20	432	1.1	1.1									5900		
	100	0.70	14	454	0.95	430	0.9	1.1									6950		
	120	0.64	12	477	0.91	471	0.9	1.0									7000		
	160	0.60	9	504	0.77	491	0.75	1.0									7000		
	200	0.57	7	459	0.59	428	0.55	1.1									7000		
	260	0.53	5	376	0.40	348	0.37	1.1									7000		
	320	0.50	4	306	0.28	273	0.25	1.1									7000		
110	30	0.82	47	537	3.20	503	3	1.1						B5			6000	T4	130
	40	0.80	35	633	2.90	480	2.2	1.3						B5			6100		
	60	0.76	23	560	1.80	560	1.8	1.0									7000		
	80	0.74	18	888	2.20	888	2.2	1.0									7200		
	100	0.72	14	884	1.80	884	1.8	1.0									7700		
	120	0.66	12	867	1.60	810	1.5	1.1									8000		
	160	0.62	9	812	1.20	744	1.1	1.1									8000		
	200	0.60	7	819	1.00	737	0.9	1.1									8000		
	260	0.55	5	732	0.75	732	0.75	1.0									8000		
	320	0.52	4	681	0.60	624	0.55	1.1									8000		
130	30	0.83	47	776	4.60	675	4	1.2						B5			6500	T4	130
	40	0.81	35	906	4.10	884	4	1.0									7000		
	60	0.77	23	1087	3.40	959	3	1.1									7500		
	80	0.75	18	1234	3.10	1194	3	1.0									7800		
	100	0.74	14	1413	3.00	1111	2.2	1.3									8300		
	120	0.68	12	1299	2.40	1191	2.2	1.1									9000		
	160	0.65	9	1517	2.20	1517	2.2	1.0									9000		
	200	0.62	7	1353	2.00	1269	1.5	1.1									9000		
	260	0.58	5	1219	1.90	1219	1.1	1.0									9000		
	320	0.55	4	1182	1.70	985	0.75	1.2									9000		



ATEX 2014/34 UE
GRUPPO II cat. 3
ZONA 2 - 22

ATEX 2014/34 EU
GROUP II cat. 3
ZONE 2 - 22

ATEX 2014/34 EU
GRUPPE II Kat. 3
ZONE 2 - 22

Dati tecnici
riduttori

Technical data
of the gearboxes

Technische Daten
der Getriebe

C3



BT

RIDUTTORI AD ASSI
ORTOGONALI

BEVEL HELICAL
GEARBOX

KEGELSTIRNRADGETRIEBE

C4



BZ

RIDUTTORI AD ASSI
PARALLELI

PARALLEL SHAFT
GEARBOX

PARALLELENGETRIEBE

C9



BP

RIDUTTORI
PENDOLARI

SHAFT-MOUNTED
GEARBOX

AUFSTECKGETRIEBE

C13



BM

RIDUTTORI
PENDOLARI

SHAFT-MOUNTED
GEARBOX

AUFSTECKGETRIEBE

C15



BR

RINVII
ANGOLARI

RIGHT ANGLE
GEARBOX

WINKELGETRIEBE

C17



BL

RINVII
ANGOLARI

RIGHT ANGLE
GEARBOX

WINKELGETRIEBE

C19



BX

RIDUTTORI A VITE
SENZA FINE

WORM
GEARBOXES

SCHNECKENGETRIEBE

C21



BK

RIDUTTORI A VITE
SENZA FINE

WORM
GEARBOXES

SCHNECKENGETRIEBE

C22



BS..K

RIDUTTORI A VITE
SENZA FINE

WORM
GEARBOXES

SCHNECKENGETRIEBE

C23



BB..K

RIDUTTORI A VITE
SENZA FINE

WORM
GEARBOXES

SCHNECKENGETRIEBE

C24



BH

RIDUTTORI A VITE SENZA
FINE CON PRECOPIA

HELICAL WORM
GEARBOXES

STIRNRAD-
SCHNECKENGETRIEBE

C27



ATEX 2014/34 UE
GRUPPO II cat. 3

ATEX 2014/34 EU
GROUP II cat. 3

ATEX 2014/34 EU
GRUPPE II Kat. 3



BKKC

RIDUTTORI A VITE
SENZA FINE COMBINATI

COMBINED WORM
GEARBOXES

KOMBINIERTE-
SCHNECKENGETRIEB

C30



BKXC

RIDUTTORI A VITE
SENZA FINE COMBINATI

COMBINED WORM
GEARBOXES

KOMBINIERTE-
SCHNECKENGETRIEB

C31



BXXC

RIDUTTORI A VITE
SENZA FINE COMBINATI

COMBINED WORM
GEARBOXES

KOMBINIERTE-
SCHNECKENGETRIEB

C32



BSCFK

RIDUTTORI A VITE
SENZA FINE COMBINATI

COMBINED WORM
GEARBOXES

KOMBINIERTE-
SCHNECKENGETRIEB

C33



BBCFK

RIDUTTORI A VITE
SENZA FINE COMBINATI

COMBINED WORM
GEARBOXES

KOMBINIERTE-
SCHNECKENGETRIEB

C34



BEP

RIDUTTORI
EPICICLOIDALI

PLANETARY
GEARBOXES

PLANETENGETRIEBE

C40



BREP

RIDUTTORI
EPICICLOIDALI

PLANETARY
GEARBOXES

PLANETENGETRIEBE

C42



BTEP

RIDUTTORI
EPICICLOIDALI ANGOLARI

RIGHT ANGLE
PLANETARY GEARBOXES

WINKEL-
PLANETENGETRIEBE

C44



BMTA

SERVO RIDUTTORI
EPICICLOIDALI

SERVO PLANETARY
GEARBOXES

PLANETENGETRIEBE

C46



BHTA

SERVO RIDUTTORI
IPOIDI

HYPOID SERVO
GEARBOXES

HYPOID-
SERVOGETRIEBE

C49



BN...

VARIATORI

VARIATORS

VERSTELLGETRIEBE

C52



BUDL

VARIATORI

VARIATORS

VERSTELLGETRIEBE

C55

Dati tecnici riduttori

Technical data of the gearboxes

Technische Daten der Getriebe

La Tramec propone per il mercato Atex famiglie di riduttori, alla cui designazione standard riportata nel "Catalogo dei Riduttori ad Ingranaggi Ortogonali e Paralleli Tramec" viene anteposta la lettera "B" a indicazione degli accorgimenti tecnici necessari al raggiungimento della conformità alla direttiva Atex 2014/34 UE e quindi certificati a lavorare in ambiente potenzialmente esplosivo:

- riduttori ad ingranaggi cilindrici con assi ortogonali serie **BT**
- riduttori ad ingranaggi cilindrici con assi paralleli serie **BZ**
- riduttori ad ingranaggi cilindrici pendolari serie **BP** e **BM**
- rinvii angolari ad ingranaggi cilindrici serie **BR** e **BL**
- riduttori a vite senza fine serie **BX, BK, BXXC, BXKC, BKKC, BH, BSFK, BSRK, BBFK, BBRK, BSCFK, BSCRK, BBCFK** e **BBCRK**.
- riduttori epicicloidali serie **BEP, BREP, BTEP, BMTA** e **BHTA**.

Tutte le informazioni serie **BNF** e **BUDL** riduttore acquistato sono contenute e/o rintracciabili attraverso i dati riportati nella targhetta di identificazione del riduttore stesso e le tavole ricambi complete di tutte le versioni della famiglia di riduttori Atex sono disponibili e consultabili nel "Catalogo di uso e manutenzione Tramec" presente sul sito aziendale "www.Tramec.it".

Tramec offers on the Atex market series of gearboxes. Letter "B" is placed before the standard designation given in the "Tramec Helical and Bevel Helical Gearboxes Catalogue" as an indication of the technical changes the gearbox was subject to in order to make it compliant with Atex Directive 2014/34 EC and therefore certified to work in a potentially explosive environment:

- Bevel helical gearboxes **BT** series
- Parallel shaft gearboxes **BZ** series
- Shaft-mounted gearboxes **BP** and **BM** series
- Right angle gearboxes **BR** and **BL** series
- Worm gearboxes **BX, BK, BXXC, BXKC, BKKC, BH, BSFK, BSRK, BBFK, BBRK, BSCFK, BSCRK, BBCFK** and **BBCRK** series
- Planetary gearboxes **BEP, BREP, BTEP, BMTA** and **BHTA** series
- Variators **BNF** and **BUDL** series

Specific information pertaining the purchased gearbox are contained and/or traceable through the data reported on the identification plate; spare parts tables, complete with all Atex versions, are available and consultable in the "Tramec Use and Maintenance Manual" on the company's web site "www.Tramec.it".

Tramec bietet auf dem Atex-Markt Serien von Getrieben. Der Buchstabe "B" wird vor der im "Tramec Untersetzungsgetriebekatalog" angegebenen Standardbezeichnung vorangesetzt, um darauf hinzuweisen, dass die Getriebe Atex-konform 2014/34 UE sind und deswegen zum Einsatz in explosionsgefährdeten Bereichen zugelassen sind:

- Kegelstirnradgetriebe Serie **BT**
- Parallelengetriebe Serie **BZ**
- Aufsteckgetriebe Serie **BP** und **BM**
- Winkelgetriebe Serie **BR** und **BL**
- Schneckengetriebe Serien **BX, BK, BXXC, BXKC, BKKC, BH, BSFK, BSRK, BBFK, BBRK, BSCFK, BSCRK, BBCFK** und **BBCRK**.
- Planetengetriebe Serien **BEP, BREP, BTEP, BMTA** und **BHTA**.
- Verstellgetriebe Serien **BNF** und **BUDL**

Spezifische Daten über das erworbene Getriebe sind auf dem Typenschild des Getriebes zu finden. Ersatzteillisten für jede Atex-Getriebeserie sind in der "Tramec Betriebs- und Wartungsanleitung" auf die Webseite "www.Tramec.it" verfügbar.

SIMBOLO SYMBOL KURZZEICHEN	DEFINIZIONE	DEFINITION	ERLÄUTERUNG	UNITA' DI MISURA UNIT OF MEASURE MABEINHEIT
i	Rapporto di riduzione nominale riduttori serie EP, REP, TEP, HTA, MTA	Nominal reduction ratio gearboxes serie EP, REP, TEP, HTA, MTA	Nennübersetzungsverhältnis Planetengetriebe EP, REP, TEP, HTA, MTA	
i _n	Rapporto di riduzione nominale	Nominal reduction ratio	Nennübersetzungsverhältnis	
i _r	Rapporto di riduzione reale	Actual reduction ratio	Reelles Übersetzungsverhältnis	
J	Momento d'inerzia riferito all'albero entrata	Moment of inertia referred to input shaft	Trägheitsmoment bzw. Antriebswelle	kg.cm ²
IEC	Motori accoppiabili	Motor options	Passende Motoren	
L _h	Durata cuscinetti	Bearing life	Lebensdauer der Lager	h
LpA	Livello di rumorosità dB(A) a 3000 min ⁻¹	Noise level dB(A) at 3000 min ⁻¹	Geräuschpegel dB(A) bei 3000 min ⁻¹	dB(A)
n ₁	Numero di giri in entrata	Revolutions at input	Drehzahl am Antrieb	
n _{1max}	Velocità massima in entrata	Maximum input speed	Maximale Eingangsdrehzahl	giri/1' rpm
n _{1nom}	Velocità nominale in entrata	Nominal input speed	Nenn-Eingangsdrehzahl	Umdrehungen/1'
n ₂	Numero di giri in uscita	Revolutions at output	Drehzahl am Abtrieb	
P	Potenza in entrata versione albero	Power at input shaft version	Leistung am Antrieb Version mit Welle	kW
P ₁	Potenza in entrata versione IEC	Power at input IEC version	Leistung am Antrieb - IEC Version	
F _{A2}	Carico assiale in uscita	Output axial load	Axiallast an der Abtriebswelle	
F _{R1}	Carico radiale in entrata	Radial load at input	Querkraft am Antrieb	N
F _{R2}	Carico radiale in uscita	Radial load at output	Querkraft am Abtrieb	
R _d	Rendimento dinamico	Dynamic efficiency	Dynamischer Wirkungsgrad	
R _t	Rigidità torsionale	Torsional stiffness	Drehfestigkeit	Nm / arcmin
T ₂	Coppia in uscita versione IEC	Output torque IEC version	Drehmoment am Abtrieb - IEC Version	
T _{2M}	Coppia massima in uscita	Maximum torque at output	Max. Drehmoment am Abtrieb	
T _{2A}	Massima coppia di accelerazione in uscita	Max. acceleration torque at output	Maximales Beschleunigungsdrehmoment am Abtrieb	Nm
T _{2N}	Coppia nominale intermittente in uscita	Rated intermittent output torque	Nenn-Abtriebsmoment (im Aussetzbetrieb)	
T _{2S}	Coppia massima di emergenza in uscita	Maximum emergency output torque	Max. Notmoment am Abtrieb	

Dati tecnici

Technical data

Technische Daten

BT	n ₁ = 1400 rpm			BTA		BTF				BTF - BTA		Classe / Class / Klasse [°C]	
	i _n	i _r	n ₂ rpm	T _{2M} Nm	P kW	T ₂ Nm	P ₁ kW	F _{sa}	IEC	F _{R1} N	F _{R2} N	3G	3D
56B	8	8.06	174	88	1.69	78	1.5	1.1	56 63 (B5) BTF 71 80 90 (B14) BTF	-	1300	T4	130
	10	10.17	138	97	1.48	72	1.1	1.3			1300		
	12.5	12.31	114	107	1.34	88	1.1	1.2			1300		
	16	15.00	93	116	1.20	107	1.1	1.1			1800		
	20	20.33	69	118	0.89	99	0.75	1.2			1800		
	25	24.62	57	118	0.74	88	0.55	1.3			1800		
	31.5	30.00	47	120	0.62	107	0.55	1.1			1800		
	40	39.38	36	122	0.48	94	0.37	1.3			2300		
50	48.00	29	123	0.40	115	0.37	1.1	2300					
56C	40	40.28	35	122	0.48	95	0.37	1.3	56 63 (B5) BTF 71 (B5) (B14) BTF	-	2300	T4	130
	50	50.83	28	126	0.39	119	0.37	1.1			2300		
	63	61.54	23	126	0.32	98	0.25	1.3			2300		
	80	75.00	19	131	0.27	86	0.25	1.1			2800		
	100	101.67	14	131	0.20	116	0.18	1.1			2800		
	125	123.08	11	131	0.17	102	0.13	1.3			2800		
	160	150.00	9	131	0.14	124	0.13	1.1			2800		
	200	196.92	7	131	0.10	112	0.09	1.2			3000		
250	240.00	6	135	0.09	91	0.09	1.0	3000					
63B	8	7.94	176	124	2.71	93	1.8	1.3	56 63 (B5) BTF 71 80 90 (B5) (B14) BTF	-	1500	T4	130
	10	10.18	138	138	2.32	119	1.8	1.2			1500		
	12.5	12.50	112	152	2.06	122	1.5	1.2			1500		
	16	15.88	88	166	1.75	154	1.5	1.1			2000		
	20	20.36	69	168	1.36	145	1.1	1.2			2000		
	25	25.00	56	170	1.11	122	0.75	1.4			2000		
	31.5	31.00	45	172	0.90	151	0.75	1.1			2000		
	40	40.00	35	174	0.69	143	0.55	1.2			2500		
	50	49.60	28	174	0.56	177	0.55	1.0			2500		
63	60.80	23	151	0.39	146	0.37	1.0	2500					
63C	40	39.71	35	180	0.71	139	0.55	1.3	56 63 (B5) BTF 71 (B5) (B14) BTF	-	2500	T4	130
	50	50.89	28	189	0.59	178	0.55	1.1			2500		
	63	62.50	22	189	0.48	147	0.37	1.3			2500		
	80	79.41	18	189	0.38	126	0.37	1.0			3000		
	100	101.79	14	189	0.29	161	0.25	1.2			3000		
	125	125.00	11	189	0.24	143	0.18	1.3			3000		
	160	155.00	9	189	0.19	128	0.18	1.1			3000		
	200	200.00	7	189	0.15	165	0.13	1.1			3500		
	250	248.00	6	189	0.12	142	0.09	1.3			3500		
315	304.00	5	162	0.08	116	0.06	1.4	3500					
75B	8	7.87	178	245	4.8	204	4.0	1.2	71 80 90 100 112 (B5) (B14) BTF	-	2500	T4	130
	10	9.82	143	279	4.4	254	4.0	1.1			2500		
	12.5	12.67	110	330	4.0	330	4.0	1.0			2500		
	16	15.43	91	329	3.3	299	3.0	1.1			2500		
	20	19.38	72	360	2.9	277	2.2	1.3			3000		
	25	25.00	56	356	2.2	356	2.2	1.0			3000		
	31.5	30.45	46	391	2.0	355	1.8	1.1			3000		
	40	40.00	35	371	1.4	285	1.1	1.3			3500		
	50	48.73	29	378	1.2	344	1.1	1.1			3500		
75C	50	49.08	29	330	1.1	330	1.1	1.0	63 (B5) BTF 71 80 90 (B5) (B14) BTF	-	3500	T4	130
	63	63.33	22	333	0.8	303	0.75	1.1			3500		
	80	77.15	18	352	0.70	271	0.55	1.3			3500		
	100	96.88	14	350	0.55	350	0.55	1.0			4000		
	125	125.00	11	359	0.44	299	0.37	1.2			4000		
	160	152.27	9	346	0.35	247	0.25	1.4			4000		
	200	200.00	7	380	0.30	317	0.25	1.2			4500		
	250	243.64	6	370	0.25	370	0.25	1.0			4500		

Dati tecnici
Technical data
Technische Daten

BT	$n_1 = 1400 \text{ rpm}$			BTA		BTC - BTF				BTC - BTF - BTA			
	i_n	i_r	n_2 rpm	T_{2M} Nm	P kW	T_2 Nm	P_1 kW	F_{sa}	IEC	F_{R1} N	F_{R2} N	Classe / Class / Klasse [°C] 3G 3D	
71B	10	10.25	137	184	2.77	120	1.8	1.5	63 71 80 90 (B5) BTC-BTF	400	3000	T4	130
	12.5	13.05	107	194	2.30	152	1.8	1.0			3150		
	16	15.63	90	205	2.02	182	1.8	1.1			3350		
	20	19.64	71	241	1.89	229	1.8	1.1			3550		
	25	24.99	56	235	1.45	243	1.5	1.0			3750		
	31.5	29.95	47	231	1.19	213	1.1	1.1			4000		
	40	38.73	36	206	0.82	188	0.75	1.1			4250		
	50	50.18	28	226	0.70	179	0.55	1.3			4500		
	63	60.13	23	229	0.59	214	0.55	1.1			4750		
80	77.76	18	214	0.42	186	0.37	1.1	5000					
90B	10	10.25	137	384	5.78	266	4	1.4	71 80 90 100 112 (B5) BTC-BTF	630	4750	T4	130
	12.5	13.05	107	429	5.08	338	4	1.3			5000		
	16	15.63	90	451	4.45	405	4	1.1			5300		
	20	19.64	71	515	4.04	509	4	1.0			5600		
	25	24.99	56	529	3.27	486	3	1.1			6000		
	31.5	29.95	47	476	2.45	427	2.2	1.1			6300		
	40	38.73	36	430	1.71	376	1.5	1.1			6700		
	50	50.18	28	479	1.47	358	1.1	1.3			7100		
	63	60.13	23	502	1.29	429	1.1	1.2			7500		
80	77.76	18	454	0.90	378	0.75	1.2	8000					
80C	50	52.18	27	594	1.79	497	1.5	1.2	63 71 80 90 (B5) BTC-BTF	400	8000	T4	130
	63	62.53	22	612	1.54	595	1.5	1.0					
	80	79.58	18	639	1.27	555	1.1	1.2					
	100	99.97	14	666	1.05	476	0.75	1.4					
	125	119.78	12	666	0.88	570	0.75	1.2					
	160	152.45	9	612	0.63	532	0.55	1.2					
	200	182.67	8	630	0.54	429	0.37	1.5					
	250	240.51	6	675	0.44	565	0.37	1.2					
	315	306.11	5	666	0.34	485	0.25	1.4					
	400	366.78	4	630	0.27	582	0.25	1.1					
500	474.35	3	594	0.20	542	0.18	1.1						
630	613.46	2	558	0.14	506	0.13	1.1						
112B	10	10.25	137	671	10.10	611	9.2	1.1	80 90 100 112 132 (B5) BTC-BTF	1000	7500	T4	130
	12.5	13.05	107	854	10.10	778	9.2	1.1			8000		
	16	15.63	90	902	8.90	760	7.5	1.2			8500		
	20	19.64	71	988	7.76	954	7.5	1.0			9000		
	25	24.99	56	1075	6.64	891	5.5	1.2			9500		
	31.5	29.95	47	1037	5.34	776	4	1.3			10000		
	40	38.73	36	903	3.60	753	3	1.2			10600		
	50	50.18	28	1028	3.16	715	2.2	1.1			10800		
	63	60.13	23	1091	2.80	857	2.2	1.3			11000		
80	77.76	18	961	1.91	907	1.8	1.1	11500					
100C	50	52.18	27	1170	3.53	993	3	1.2	71 80 90 100 112 (B5) BTC-BTF	630	12500	T4	130
	63	62.53	22	1215	3.06	1190	3	1.2					
	80	79.58	18	1269	2.51	1111	2.2	1.1					
	100	99.97	14	1323	2.09	1142	1.8	1.2					
	125	119.78	12	1332	1.75	1140	1.5	1.2					
	160	152.45	9	1224	1.27	1064	1.1	1.2					
	200	182.67	8	1260	1.09	869	0.75	1.4					
	250	240.51	6	1350	0.88	1144	0.75	1.2					
	315	306.11	5	1332	0.69	1068	0.55	1.2					
	400	366.78	4	1260	0.54	861	0.37	1.0					
	500	474.35	3	1224	0.41	1113	0.37	1.1					
630	613.46	2	1116	0.29	973	0.25	1.1						

• Flange quadrate

• Square flanges

• Viereckige Flansche

Dati tecnici
Technical data
Technische Daten

BT	$n_1 = 1400 \text{ rpm}$			BTA		BTC - BTF				BTC - BTF - BTA			
	i_n	i_r	n_2 rpm	T_{2M} Nm	P kW	T_2 Nm	P_1 kW	F_{sa}	IEC	F_{R1} N	F_{R2} N	Classe / Class / Klasse [°C] 3G 3D	
225B	8	8.44	166	2182	39.90	2023	37	1.1	132 160 180 200 (B5) BTF	3150	36000	T4	130
	10	10.13	138	2620	39.90	2430	37	1.1			38000		
	12.5	12.45	112	3218	39.90	2984	37	1.1			40000		
	16	15.93	88	4118	39.90	3818	37	1.1			42400		
	20	19.13	73	4945	39.90	4586	37	1.1			44800		
	25	23.49	60	6073	39.90	5632	37	1.1			47200		
	31.5	30.29	46	7831	39.90	7262	37	1.1			50000		
	40	37.09	38	9589	39.90	7210	30	1.3			53000		
180C	50	53.11	26	6516	19.30	5054	15	1.3	80 90 100 112 132 160 (B5) BTC-BTF	1400	43000	T4	130
	63	63.64	22	6552	16.20	6056	15	1.1					
	80	76.85	18	6678	13.70	5363	11	1.2					
	100	99.39	14	6750	10.70	5801	9.2	1.2					
	125	122.88	11	6750	8.65	5846	7.5	1.2					
	160	147.23	10	6795	7.25	5137	5.5	1.3					
	200	190.41	7	6840	5.65	4832	5.5	1.0					
	250	246.73	6	6885	4.40	6261	4	1.1					
	315	295.63	5	6930	3.70	5626	3	1.2					
	400	382.33	4	7155	2.95	5336	2.2	1.3					
200C	40	42.62	33	8083	29.90	8110	30	1.0	100 112 132 160 180 (B5) BTC-BTF	2000	53000	T4	130
	50	51.18	27	9708	29.90	7143	30	1.0					
	63	62.86	22	10215	25.42	8772	22	1.2					
	80	76.97	18	9945	20.37	7324	15	1.4					
	100	98.04	14	10080	16.21	9930	15	1.1					
	125	120.41	12	10350	13.55	8403	11	1.2					
	160	147.45	9	10080	10.78	8606	9.2	1.2					
	200	196.87	7	10260	8.22	9367	7.5	1.1					
	250	241.79	6	10530	6.86	8436	5.5	1.2					
	315	296.07	5	10665	5.68	7513	4	1.4					

Esecuzione
Execution
Ausführung

0

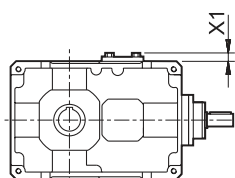

Esecuzione
Execution
Ausführung

V

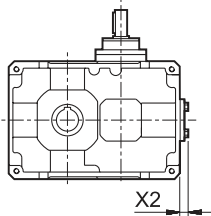

BT	X1	X2
71B - 80C	11	11
90B - 100C	14	14
112B - 125C	16	16
140B - 160C	20	20
180C	0	20
180B - 200C - 200B	21	21
225B	25	25

Riduttori ad assi paralleli
serie BZ

Parallel shaft gearboxes
BZ series

Parallelengetriebe
Serie BZ

Designazione

Designation

Bezeichnung

Macchina Machine Maschine	Tipo entrata Input type Antriebsart	Grandezza Size Größe	Rotismo Gearing Räderwerk	Rapporto rid. Ratio Untersetzungsverhältnis	Predisposiz. Motor coupling Motoranschluss	Albero uscita cavo Hollow output shaft Abtriebshohlwelle	Entrata supplementare Additional input Zusatzantrieb	Esecuzione Execution Ausführung	Posizione di montaggio Mounting position Baulage	Flangia uscita Output flange Abtriebsflansch
BZ	A	112	B	10	P.A.M.	-	S.e.A.	0	B3	FLD
Riduttore ad assi paralleli Parallel shaft gear unit Parallelengetriebe		71 90 112 140 180 225	A	$i_n =$ 5 ÷ 280	71 ÷ 200	(1)		A F	B3 V1 V3 VA VB	
		80 100 125 160 180 200	B							
		80 100 125 160 180 200	C							

(1) Indicare il diametro dell'albero cavo solo se non è standard.
Es.: BZ A 112 B 10 90 0 B3 40

(1) Diameter of the hollow output shaft to be specified only if it is not standard.
Ex.: BZ A 112 B 10 90 0 B3 40

(1) Benennen Sie bitte den Durchmesser der Abtriebshohlwelle, insofern dieser nicht dem Standarddurchmesser entspricht
Beispiel: BZ A 112 B 10 90 0 B3 40

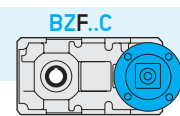
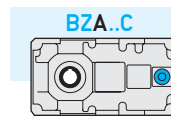
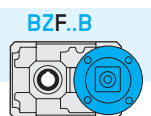
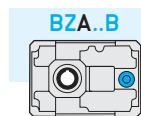
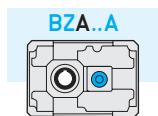

Per le dimensioni, gli accessori e le posizioni di montaggio vedere il "Catalogo dei Riduttori ad Ingranaggi Ortogonali e Paralleli Tramec".

For dimensions, accessories and mounting positions see the "Tramec Helical and Bevel Helical Gearboxes Catalogue".

Informationen über Abmessungen, Ersatzteile und Montageposition sind in dem "Tramec Untersetzungsgetriebekatalog" zu finden.

Dati tecnici
Technical data
Technische Daten

BZ	$n_1 = 1400 \text{ rpm}$			BZA				Classe / Class / Klasse [°C]	
	i_n	i_r	n_2 rpm	T_{2M} Nm	P kW	F_{R1} N	F_{R2} N	3G	3D
71A	5	5.09	275	212	6.30	400	2700	T4	130
	6.3	6.10	230	189	4.70		2700		
	8	7.89	177	162	3.10		2850		
90A	5	5.09	275	356	9.50	630	4250	T4	130
	6.3	6.1	230	426	9.50		4250		
	8	7.89	177	360	6.25		4500		
112A	5	5.09	275	482	14.30	1000	6450	T4	130
	6.3	6.10	230	577	14.30		6800		
	8	7.89	177	702	13.45		7150		
140A	5	5.09	275	741	22.00	1600	10150	T4	130
	6.3	6.10	230	888	22.00		10700		
	8	7.89	177	1148	22.00		11250		
180A	5	5.09	275	1179	35.00	2500	17250	T4	130
225A	5	4.82	291	1804	56.60	4000	36200	T4	130

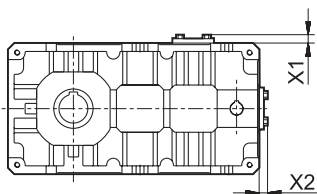

BZ	X1	X2
71A - 80B	11	11
80C	0	11
90A - 100B	14	14
100C	0	14
112A - 125B	16	16
125C	0	16
140A - 160B - 160C	0	20
180A	21	21
180B - 180C	0	20
225A	25	25
200B	21	21
200C	0	21

Dati tecnici
Technical data
Technische Daten

BZ	n ₁ = 1400 rpm			BZA		BZF				BZF - BZA			
	i _n	i _r	n ₂ rpm	T _{2M} Nm	P kW	T ₂ Nm	P ₁ kW	F _{sa}	IEC	F _{R1} N	F _{R2} N	Classe / Class / Klasse [°C]	
												3G	3D
80B	10	10.20	137	408	6.17	119	1.8	3.4	63 71 80 90 (B5)	400	5000 5300 5600 6000 6000 6300 6700 7100 7500	T4	130
	12.5	12.98	108	462	5.49	151	1.8	3.0					
	16	15.56	90	517	5.12	181	1.8	2.8					
	20	20.36	69	581	4.40	238	1.8	2.4					
	25	24.40	57	588	3.72	285	1.8	2.1					
	31.5	31.05	45	536	2.66	362	1.8	1.5					
	40	37.21	38	482	2.00	434	1.8	1.1					
	50	48.12	29	452	1.45	343	1.1	1.3					
63	62.23	22	472	1.17	444	1.1	1.1						
80C	50	52.52	27	594	1.75	500	1.5	1.2	63 71 80 90 (B5)	315	7500	T4	130
	63	62.93	22	612	1.55	439	1.1	1.4					
	80	80.09	17	639	1.25	559	1.1	1.1					
	100	105.52	13	666	1.00	602	0.9	1.1					
	125	126.44	11	666	0.85	602	0.75	1.1					
	160	160.92	9	612	0.60	561	0.55	1.1					
	200	208.11	7	630	0.50	488	0.37	1.3					
	250	249.36	6	648	0.40	585	0.37	1.1					
100B	10	10.20	137	707	10.70	264	4	2.7	71 80 90 100 112 (B5)	630	7500 8000 8500 9000 9500 10000 10600 11200 11800	T4	130
	12.5	12.98	108	990	10.70	337	4	2.7					
	16	15.56	90	1050	10.41	403	4	2.6					
	20	20.36	69	1179	8.93	528	4	2.2					
	25	24.40	57	1193	7.54	632	4	1.9					
	31.5	31.05	45	1097	5.45	805	4	1.4					
	40	37.21	38	1049	4.35	965	4	1.1					
	50	48.12	29	922	2.96	686	2.2	1.3					
63	62.23	22	933	2.31	887	2.2	1.1						
100C	50	51.93	27	1170	3.55	593	1.8	2.0	63 71 80 90 (B5)	400	11800	T4	130
	63	62.22	23	1215	3.10	710	1.8	1.7					
	80	79.19	18	1269	2.55	904	1.8	1.4					
	100	103.67	14	1323	2.00	1184	1.8	1.1					
	125	124.22	11	1332	1.70	1182	1.5	1.1					
	160	158.10	9	1224	1.20	1103	1.1	1.1					
	200	204.46	7	1260	1.00	1167	0.9	1.1					
	250	244.99	6	1296	0.85	1166	0.75	1.1					
125B	10	10.20	137	1064	16.10	608	9.2	2.8	80 90 100 112 132 (B5)	1000	11800 12500 13200 13600 14000 15000 16000 16500 17000 17500 18000 18500 19000	T4	130
	12.5	12.98	108	1354	16.10	774	9.2	2.4					
	16	15.56	90	1623	16.10	927	9.2	2.2					
	18*	17.34	81	2450	22.0	1025	9.2	2.4					
	20	20.36	69	2125	16.10	1214	9.2	1.9					
	25	24.40	57	2394	15.14	1455	9.2	1.6					
	31.5	31.05	45	2168	10.77	1851	9.2	1.2					
	35*	34.62	40	2470	11.0	2076	9.2	1.2					
	40	37.21	38	2021	8.38	1809	7.5	1.1					
	45*	41.48	34	2400	9.00	1991	7.5	1.2					
	50	48.12	29	1958	6.28	1715	5.5	1.1					
	56*	53.64	26	1950	5.6	1909	5.5	1.0					
	63	62.23	22	1980	4.91	1613	4.0	1.2					

* Rapporti speciali

* Special ratios

* Sonderverhältnisse

Dati tecnici
Technical data
Technische Daten

BZ	n ₁ = 1400 rpm			BZA		BZF				BZF - BZA															
	i _n	i _r	n ₂ rpm	T _{2M} Nm	P kW	T ₂ Nm	P ₁ kW	F _{sa}	IEC	F _{R1} N	F _{R2} N	Classe / Class / Klasse [°C]													
												3G	3D												
125C	50	51.93	27	2385	7.25	1318	4	1.8	71 80 90 100 112 (B5)	630	19000	T4	130												
	63	62.22	23	2484	6.30	1579	4	1.6																	
	80	79.19	18	2592	5.15	2009	4	1.3																	
	100	103.67	14	2700	4.10	1973	3	1.4																	
	125	124.22	11	2700	3.45	2364	3	1.1																	
	160	158.10	9	2448	2.45	2206	2.2	1.1																	
	200	204.46	7	2520	1.95	2335	1.8	1.1																	
	250	244.99	6	2592	1.70	2331	1.5	1.1																	
160B	10	10.20	137	3600	25.70	1454	22	1.2	80 90 100 112 120 132 160 180 (B5)	1600	19000	20000	21200	21800	22400	23600	25000	25500	26500	27500	28000	29000	30000	T4	130
	12.5	12.98	108	4050	25.70	1851	22	1.2																	
	16	15.56	90	4410	25.70	2218	22	1.2																	
	18*	17.34	81	5200	46.00	2451	22	2.1																	
	20	20.36	69	4950	25.70	2903	22	1.2																	
	25	24.40	57	4950	25.70	3479	22	1.2																	
	31.5	31.05	45	4680	21.95	4427	22	1.0																	
	35*	34.62	40	5300	24.00	4964	22	1.1																	
	40	37.21	38	4230	16.76	3617	15	1.1																	
	45*	41.48	34	5000	18.50	4911	18.5	1.0																	
	50	48.12	29	3870	12.00	3430	11	1.1																	
	56*	53.64	26	3800	11.00	3818	11	1.0																	
	63	62.23	22	3870	9.40	3025	7.5	1.3																	
	160C	50	51.93	27	4617	14.00	3031	9.2																	
63		62.22	23	4815	12.20	3631	9.2	1.3																	
80		79.19	18	5013	10.00	4622	9.2	1.1																	
100		103.67	14	5220	8.00	4933	7.5	1.1																	
125		124.22	11	5220	6.85	4334	5.5	1.2																	
160		158.10	9	4923	5.00	4012	4	1.2																	
180*		176.24	8	5600	5.00	4418	4	1.3																	
200		204.46	7	5040	3.90	3891	3	1.3																	
250		244.99	6	5184	3.50	4663	3	1.1																	
280*		273.10	5	5700	3.30	5301	3	1.1																	
180B	8	8.10	173	1680	32.00	1155	22	1.5	80 90 100 112 132 160 180 (B5)	2000	26800	28800	30400	32200	34000	35800	37600	39400	T4	130					
	10	10.38	135	2150	32.00	1480	22	1.5																	
	12.5	12.54	112	2600	32.00	1787	22	1.5																	
	16	16.17	87	3350	32.00	2305	22	1.5																	
	20	20.73	68	4300	32.00	2955	22	1.5																	
	25	25.03	56	5190	32.00	3569	22	1.5																	
	31.5	31.05	45	6440	32.00	4427	22	1.5																	
	40	35.07	40	6570	28.90	5000	22	1.3																	
	180C	50	52.85	26	6777	20.20	3085	9.2													2.2	80 90 100 112 132 (B5)	1250	43000	T4
63		63.33	22	6804	17.00	3696	9.2	1.8																	
80		76.48	18	6930	14.25	4464	9.2	1.6																	
100		94.89	15	6885	11.45	5538	9.2	1.2																	
125		127.43	11	6912	8.55	6063	7.5	1.1																	
160		152.68	9	7047	7.30	5327	5.5	1.3																	
200		197.46	7	7083	5.65	5011	4	1.4																	
250		244.99	6	7164	4.60	6217	4	1.2																	
200B	8	8.33	168	2260	41.90	1619	30	1.4	100 112 132 160 180 200 (B5)	2500	38000	40000	42400	44800	47200	50000	53000	T4	130						
	10	10.00	140	2720	41.90	1945	30	1.4																	
	12.5	12.29	114	3340	41.90	2389	30	1.4																	
	16	16.63	84	4515	41.90	3233	30	1.4																	
	20	19.97	70	5425	41.90	3883	30	1.4																	
	25	24.53	57	6660	41.90	4769	30	1.4																	
	31.5	30.04	47	8155	41.90	5839	30	1.4																	
	200C	40	42.41	33	8044	29.90	5919	22												1.4	80 100 112 132 160 180 (B5)	1600	53000	T4	130
50		50.93	27	9660	29.90	7108	22	1.4																	
63		62.55	22	11350	28.60	8730	22	1.3																	
80		76.59	18	11050	22.75	8989	18.5	1.2																	
100		101.68	14	11200	17.35	9675	15	1.2																	
125		124.87	11	11500	14.50	8714	11	1.3																	
160		152.91	9	11200	11.55	8925	11	1.0																	

* Rapporti speciali

* Special ratios

* Sonderverhältnisse

Riduttori pendolari
serie BP

Shaft-mounted gearboxes
BP series

Aufsteckgetriebe
Serie BP

Designazione

Designation

Bezeichnung

Macchina Machine Maschine	Tipo entrata Input type Antriebsart	Grandezza Size Größe	Diámetro albero lento Output shaft diameter Durchmesser der Abtriebswelle	Rotismo Gearing Räderwerk	Rapporto rid. Ratio Untersetzungsverhältnis	Predisposiz. Motor coupling Motoranschluss	Tenditore Tensioner Spannvorrichtung	Esecuzione Execution Ausführung	Posizione di montaggio Mounting position Baulage	Flangia uscita Output flange Abtriebsflansch
BP	A	100	45	B	10/1	P.A.M.	-	0	VA	FLD
Riduttore pendolare Shaft mounted gearbox Aufsteckgetriebe		63 80 100 125 160	$25 \frac{D_2}{\pm 70}$		$5 \frac{i_2}{\pm 63}$	63 180	 TE solo only nur PA...	0	P1 P2 P3 P4 VA VB	 FLD solo only nur PC...B

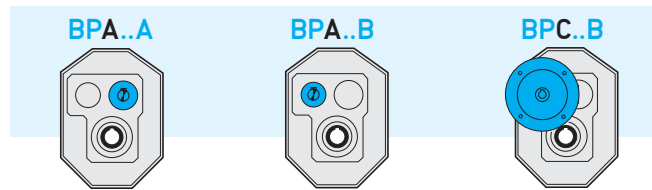

Per le dimensioni, gli accessori e le posizioni di montaggio vedere il "Catalogo dei Riduttori ad Ingranaggi Ortogonali e Paralleli Tramec".

For dimensions, accessories and mounting positions see the "Tramec Helical and Bevel Helical Gearboxes Catalogue".

Informationen über Abmessungen, Ersatzteile und Montageposition sind in dem "Tramec Untersetzungsgetriebekatalog" zu finden.

Dati tecnici

Technical data

Technische Daten

BP	$n_1 = 1400 \text{ rpm}$			BPA				Classe / Class / Klasse	
	i_n	i_r	n_2 rpm	T_{2M} Nm	P kW	F_{R1} N	F_{R2} N	[°C]	
								3G	3D
63A	5	5.09	275	171	5.00	350	2040	T4	130
	6.3	6.10	230	162	4.00		2160		
	8	7.89	177	153	3.00		2280		
80A	5	5.09	275	303	9.00	400	4000	T4	130
	6.3	6.10	230	324	8.00		4250		
	8	7.89	177	306	5.85		4500		
100A	5	5.09	275	461	13.70	1000	6450	T4	130
	6.3	6.10	230	553	13.70		6800		
	8	7.89	177	612	11.70		7150		
125A	5	5.09	275	677	20.10	1600	10150	T4	130
	6.3	6.10	230	811	20.10		10700		
	8	7.89	177	1049	20.10		11250		
160A	5	5.09	275	1060	31.50	2500	13120	T4	130

Dati tecnici
Technical data
Technische Daten

BP	n ₁ = 1400 rpm			BPA		BPC				BPC - BPA			
	i _n	i _r	n ₂ rpm	T _{2M} Nm	P kW	T ₂ Nm	P ₁ kW	F _{sa}	IEC	F _{R1} N	F _{R2} N	Classe / Class / Klasse [°C]	
												3G	3D
63B	10	10.35	135	207	3.10	121	1.8	1.7	63 71 80 90 (B5) 80 (B14)	315	1140	T4	130
	12.5	13.18	106	216	2.50	154	1.8	1.4			1340		
	16	15.79	89	216	2.10	184	1.8	1.2			1480		
	20	20.33	69	234	1.80	198	1.5	1.2			1910		
	25	25.88	54	243	1.45	184	1.1	1.3			1930		
	31.5	31.01	45	252	1.25	221	1.1	1.1			2180		
	40	40.10	35	243	0.95	195	0.75	1.2			2400		
80B	10	10.20	137	390	5.90	264	4	1.5	71 80 90 100 112 (B5) 90* B14	400	2800	T4	130
	12.5	12.98	108	432	5.15	337	4	1.3			3100		
	16	15.56	90	450	4.45	403	4	1.1			3450		
	20	20.36	69	468	3.55	396	3	1.2			3820		
	25	24.40	57	486	3.00	348	2.2	1.4			4200		
	31.5	31.05	45	504	2.50	443	2.2	1.1			4630		
	40	37.21	38	486	2.00	434	1.8	1.1			5100		
	50	48.12	29	468	1.50	343	1.1	1.4			5580		
	63	62.23	22	450	1.10	363	0.9	1.2			6000		
100B	10	10.20	137	588	8.90	608	9.2	1.0	80 90 100 112 132 (B5)	630	3250	T4	130
	12.5	12.98	108	749	8.90	774	9.2	1.0			3700		
	16	15.56	90	897	8.90	756	7.5	1.2			4220		
	20	20.36	69	936	7.00	726	5.5	1.3			4780		
	25	24.40	57	972	6.15	870	5.5	1.1			5350		
	31.5	31.05	45	1008	5.00	805	4	1.3			6160		
	40	37.21	38	972	4.00	723	3	1.3			6700		
	50	48.12	29	936	3.00	686	3	1.0			7430		
	63	62.23	22	900	2.25	726	1.8	1.2			8060		
125B	10	10.20	137	865	13.10	727	11	1.2	80 90 100 112 132 160 (B5)	1000	5150	T4	130
	12.5	12.98	108	1100	13.10	925	11	1.2			5830		
	16	15.56	90	1320	13.10	1110	11	1.2			6590		
	18*	17.34	81	2200	19.50	2072	18.5	1.1			7010		
	20	20.36	69	1729	13.10	1452	11	1.2			7430		
	25	24.40	57	2070	13.10	1739	11	1.2			8280		
	31.5	31.05	45	2016	10.00	1509	7.5	1.3			9245		
	35*	34.62	40	2350	10.50	2087	9.2	1.1			9770		
	40	37.21	38	1944	8.00	1809	7.5	1.1			10300		
	45*	41.48	34	2280	8.50	2001	7.5	1.1			10840		
	50	48.12	29	1872	6.00	1715	5.5	1.1			11380		
	56*	53.64	26	1740	5.00	1396	4	1.2			11840		
	63	62.23	22	1800	4.45	1613	4	1.1			12310		
160B	10	10.20	137	1355	20.50	1225	18.5	1.1	100 112 132 160 180 (B5)	1600	9580	T4	130
	12.5	12.98	108	1725	20.50	1555	18.5	1.1			10680		
	16	15.56	90	2066	20.50	1865	18.5	1.1			11925		
	18*	17.34	81	4350	39.00	3360	30	1.3					
	20	20.36	69	2705	20.50	2440	18.5	1.1			13290		
	25	24.40	57	3240	20.50	2925	18.5	1.1			14680		
	31.5	31.05	45	4032	20.00	37.23	18.5	1.1			16250		
	35*	34.62	40	4480	20.00	4196	18.5	1.1					
	40	37.21	38	3888	16.10	3615	15	1.1			17970		
	45*	41.48	34	4430	16.50	4003	15	1.1					
	50	48.12	29	3744	12.00	3430	11	1.1			19720		
	56*	53.64	26	3450	9.90	3210	9.2	1.1					
	63	62.23	22	3600	9.00	3025	7.5	1.2			21250		

- Flange quadrate
- * Rapporti speciali

- Square flanges
- * Special ratios

- Viereckige Flansche
- * Sonderverhältnisse

Riduttori pendolari
serie BM

Shaft-mounted gearboxes
BM series

Aufsteckgetriebe
Serie BM

Designazione

Designation

Bezeichnung

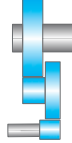
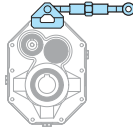
Macchina Machine Maschine	Tipo entrata Input type Antriebsart	Grandezza Size Größe	Diametro albero lento Output shaft diameter Durchmesser der Abtriebswelle	Rotismo Gearing Räderwerk	Rapporto rid. Ratio Untersetzungsverhältnis	Tenditore Tensioner Spannvorrichtung	Esecuzione Execution Ausführung	Posizione di montaggio Mounting position Baulage
BM	A	100	55	B	10/1	TE	0	P1
Riduttore pendolare Shaft mounted gearbox Aufsteckgetriebe	 A	63 80 100 125 140 160 180	D_2 35 ÷ 100	 B	$i_n =$ 12.5 ÷ 25		0	P1 P2 P3 P4

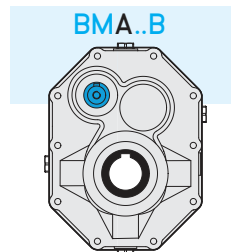

Per le dimensioni, gli accessori e le posizioni di montaggio vedere il "Catalogo dei Riduttori ad Ingranaggi Ortogonali e Paralleli Tramec".

For dimensions, accessories and mounting positions see the "Tramec Helical and Bevel Helical Gearboxes Catalogue".

Informationen über Abmessungen, Ersatzteile und Montageposition sind in dem "Tramec Untersetzungsgetriebekatalog" zu finden.

Dati tecnici
Technical data
Technische Daten

BM	$n_1 = 1400 \text{ rpm}$			BMA				Classe / Class / Klasse [°C]	
	i_h	i_r	n_2 rpm	T_{2M} Nm	P kW	F_{R1} N	F_{R2} N	3G	3D
63B	12.5	12.83	109	225	2.70	360	-	T4	130
	16	16.01	87	261	2.50				
	20	20.66	68	279	2.00				
	25	25.17	56	297	1.80				
80B	12.5	12.91	108	423	5.00	470	-	T4	130
	16	16.55	85	522	4.85				
	20	19.99	70	558	4.30				
	25	24.80	56	580	3.60				
100B	12.5	12.91	108	610	7.30	710	-	T4	130
	16	16.55	85	785	7.30				
	20	19.99	70	945	7.30				
	25	24.80	56	1100	6.85				
125B	12.5	12.90	109	878	10.5	1040	-	T4	130
	16	16.53	85	1125	10.5				
	20	19.97	70	1360	10.5				
	25	24.78	56	1685	10.5				
140B	12.5	12.91	108	1155	13.8	1400	-	T4	130
	16	16.55	85	1480	13.8				
	20	19.99	70	1790	13.8				
	25	24.80	56	2220	13.8				
160B	12.5	13.38	105	1675	19.3	1940	-	T4	130
	16	17.13	82	2140	19.3				
	20	20.67	68	2585	19.3				
	25	25.62	55	3204	19.3				
180B	12.5	13.15	106	2320	27.2	2200	-	T4	130
	16	16.86	83	2970	27.2				
	20	20.37	69	3590	27.2				
	25	25.27	55	4450	27.2				

Rinvii angolari
serie BR

Right angle gearboxes
BR series

Winkelgetriebe
Serie BR

Designazione

Designation

Bezeichnung

Macchina Machine Maschine	Tipo entrata Input type Antriebsart	Grandezza Size Größe	Rotismo Gearing Räderwerk	Tipo uscita Output type Ausgang Typ	Rapporto rid. Ratio Untersetzungsverhältnis	Predisposizione att. mot. Motor coupling Motorschluss	Entrata supplementare Additional input Zusatzantrieb	Rotazione alberi Shafts rotation Wellendrehrichtungen	Posizione di montaggio Mounting position Baulage	Flangia uscita Output flange Abtriebsflansch
BR	A	28	A	S	10	P.A.M.	S.e.A.	B	B3	FLD
Rinvii angolari Right angle gearboxes Winkelgetriebe	A C F	19 24 28 38 48	A	S B C	$i_n =$ 1 2.5 5 10	63 ÷ 200	A C F	A B C D E F G H I L	B3 B6 B7 B8 VA VB	FLS FLD FL2

Tipo entrata

Input type

Antriebstyp

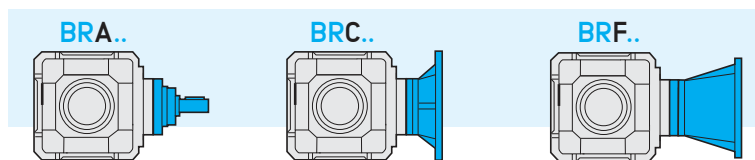

Per le dimensioni, gli accessori e le posizioni di montaggio vedere il "Catalogo dei Riduttori ad Ingranaggi Ortogonali e Paralleli Tramec".

For dimensions, accessories and mounting positions see the "Tramec Helical and Bevel Helical Gearboxes Catalogue".

Informationen über Abmessungen, Ersatzteile und Montageposition sind in dem "Tramec Untersetzungsgetriebekatalog" zu finden.

Dati tecnici
Technical data
Technische Daten

BR	n ₁ = 1400 rpm			BRA		BRC - BRF					BRC - BRF - BRA			Classe / Class / Klasse [°C]	
	i _n	i _r	n ₂ rpm	T _{2M} Nm	P kW	T ₂ Nm	P ₁ kW	F _{sa}	IEC		F _{R1} N	F _{R2[D2]} N	F _{R2[D3]} N	3G	3 D
19	1	1	1400	30	4.50	12	1.8	2.5	63 71 (B5) BRF	63 71 80 90	400	800	800	T4	130
	2.5	2.56	546	46	2.70	31	1.8	1.5				1000	630		
	5	4.91	285	44	1.35	24	1.1	1.2				1250	800		
	10	9.86	142	44	0.70	36	0.55	1.2	80 90			1600	1000		
24	1	1	1400	44	6.70	26	4	1.7	71 80 (RF)	71 80 90 100 112	630	1250	1250	T4	130
	2.5	2.56	546	84	5.00	68	4	1.2				1600	1000		
	5	4.91	285	88	2.70	49	1.5	1.2	90			2000	1250		
	10	9.86	142	88	1.35	49	1.1	1.2	100 112			2500	1600		
28	1	1	1400	68	10.30	61	9.2	1.1	80 90 (RF)	80 90 100 112 132	1000	2000	2000	T4	130
	2.5	2.56	546	168	9.90	156	9.2	1.1				2500	1600		
	5	4.91	285	161	5.00	130	4	1.2	100 112			3150	2000		
	10	9.86	142	176	2.70	143	2.2	1.2	132			4000	2500		
38	1	1	1400	101	15.30	99	15	1.0	80 90 100 112 (RF)	80 90 (RC) 100 112 132 160	1600	3150	3150	T4	130
	2.5	2.56	546	259	15.30	254	15	1.0				4000	2500		
	5	4.91	285	322	9.90	244	7.5	1.3				5000	3150		
	10	9.86	142	323	5.00	261	4	1.2	132 160			6300	4000		
48	1	1	1400	148	22.40	146	22	1.0			2500	5000	5000	T4	130
	2.5	2.56	546	380	22.40	373	22	1.0	132 160 180	132 160 180		6300	4000		
	5	4.91	285	643	19.80	601	18.5	1.1				8000	5000		
	10	9.86	142	646	9.90	600	9.2	1.1				10000	6300		

• Flange quadrata

• Square flanges

• Viereckige Flansche

Rinvii angolari
serie BL

Right angle gearboxes
BL series

Winkelgetriebe
Serie BL

Designazione

Designation

Bezeichnung

Macchina Machine Maschine	Tipo entrata Input type Antriebsart	Grandezza Size Größe	Rotismo Gearing Räderwerk	Tipo uscita Output type Ausgang Typ	Rapporto rid. Ratio Untersetzungsverhältnis	Predisposizione att. mot. Motor coupling Motoranschluss	Entrata supplementare Additional input Zusatzantrieb	Rotazione alberi Shafts rotation Wellendrehrichtungen	Posizione di montaggio Mounting position Baulage	Flangia uscita Output flange Abtriebsflansch
BL	A	28	A	C	2	P.A.M.	S.e.A.	B	B3	FLD
Rinvii angolari Right angle gearboxes Winkelgetriebe	A C F	19 24 28 38 48	A	S B C	$i_n =$ 1 2 3	63 ÷ 200	A C F	A B C D E F	B3 B6 B7 B8 VA VB	FLS FLD FL2

Tipo entrata

Input type

Antriebstyp

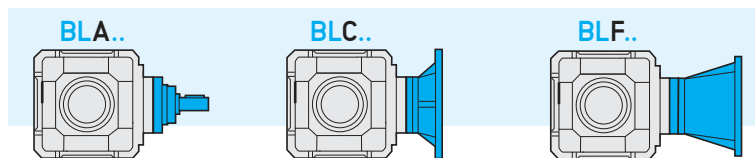

Per le dimensioni, gli accessori e le posizioni di montaggio vedere il "Catalogo dei Riduttori ad Ingranaggi Ortogonali e Paralleli Tramec".

For dimensions, accessories and mounting positions see the "Tramec Helical and Bevel Helical Gearboxes Catalogue".

Informationen über Abmessungen, Ersatzteile und Montageposition sind in dem "Tramec Untersetzungsgetriebekatalog" zu finden.

Dati tecnici
Technical data
Technische Daten

BL	n ₁ = 1400 rpm			BLA		BLC - BLF				BLC - BLF - BLA			
	i _n	i _r	n ₂ rpm	T _{2M} Nm	P kW	T ₂ Nm	P ₁ kW	F _{sa}	IEC	F _{R1} N	F _{R2} N	Classe / Class / Klasse [°C] 3G 3D	
19	1	1	1400	35	5.5	12	1.8	3	63 71 80 90 (B5) 80 (B14)	400	800	T4	130
	2	2	700	40	3	24	1.8	1.7					
	3	3	467	43	2.2	36	1.8	1.2					
24	1	1	1400	73	11	26	4	2.7	71 80 90 100 112 (B5) 90 • (B14)	630	1250	T4	130
	2	2	700	72	5.5	53	4	1.4					
	3	3	467	78	4	78	4	1					
28	1	1	1400	146	22	61	9.2	2.4	80 90 100 112 132	1000	2000	T4	130
	2	2	700	145	11	122	9.2	1.2					
	3	3	467	182	9.2	182	9.2	1					
38	1	1	1400	298	45	298	45	2	90 100 112 132 160 180	1600	3150	T4	130
	2	2	700	291	22	291	22	1					
	3	3	467	297	15	297	15	1					
48	1	1	1400	596	90	199	30	3	100 112 132 160 180 200	2500	5000	T4	130
	2	2	700	583	45	397	30	1.5					
	3	3	467	597	30	597	30	1					

• Flange quadrata

• Square flanges

• Viereckige Flansche

Riduttori a vite
senza fine BX





Worm gearboxes
BX

Schneckengetriebe
BX

Designazione

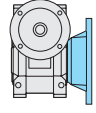
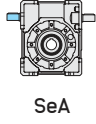
Designation

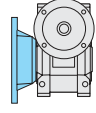
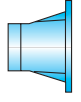
Bezeichnung

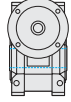
Riduttore Gearbox Getriebe	Tipo entrata Input type Antriebsart	Grandezza Size Größe	Rapporto rid. Ratio Untersetzung	Predispos.att. mot. Motor coupling Motoranschluss	Albero uscita cavo Hollow output shaft Abtriebshohlwelle	Flangia in uscita. Output flange Abtriebsflansch	Seconda entrata Additional input Zusatzantrieb	Posizione di mont. Mounting position Einbaulage
BX	A	50	10/1	P.A.M	H25	F1S	SeA	B3
Riduttore a vite senza fine Wormgearbox Schneckengetriebe	 A	30 40 50 63 75 89*	5 7.5 10 15 20 25 30 40 50 65 80 100	56 63 71 80 90 100 112 132	vedi tabelle see tables siehe Tabellen	 F1D-F2D-F3D	 SeA	B3, B6 B7, B8 V5, V6
	 C	 Alluminio Aluminium Aluminium	90 110 130			 F1S-F2S-F3S		
	 F	 Ghisa Cast iron Gusseisen				 F12-F22-F32		

*: 89 solo con tipo di entrata C

*: 89 only with input type C

*: 89 nur mit Antriebsart C

Tipo entrata

Input type

Antriebstyp

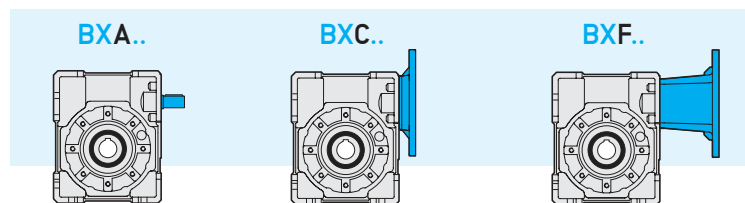

Per le dimensioni, gli accessori e le posizioni di montaggio vedere il "Catalogo dei Riduttori a Vite Senza Fine Tramec".

For dimensions, accessories and mounting positions see the "Tramec Worm Gearboxes Catalogue".

Informationen über Abmessungen, Ersatzteile und Montageposition sind in dem "Tramec Schneckengetriebe-katalog".

Designazione

Designation

Bezeichnung

Riduttore Gearbox Getriebe	Tipo entrata Input type Antriebsart	Grandezza Size Größe	Versione Version Ausführung	Rapporto rid. Ratio Untersetzung	Predispos.att. mot. Motor coupling Motoranschluss	Albero uscita cavo Hollow output shaft Abtriebshohlwelle	Flangia uscita Output flange Abtriebsflansch	Seconda entrata Additional input Zusatzantrieb	Posizione di mont. Mounting position Einbaulage
BK	C	50	A1	10	P.A.M	H25	F1S	SeA	B3
Riduttore a vite senza fine Wormgearbox Schneckengetriebe		30 40 50 63 75 89 90 110 130 Alluminio Aluminium Aluminiumium Ghisa Cast iron Gusseisen	A1-A2 B1-B2 V1-V2 P	5 7.5 10 15 20 25 30 40 50 65 80 100	56 63 71 80 90 100 112 132	vedi tabelle see tables siehe Tabellen 	F1S-F2S F3S F1D-F2D F3D	 SeA	B3 B6 B7 B8 V5 V6

Versioni

Versions

Ausführungen

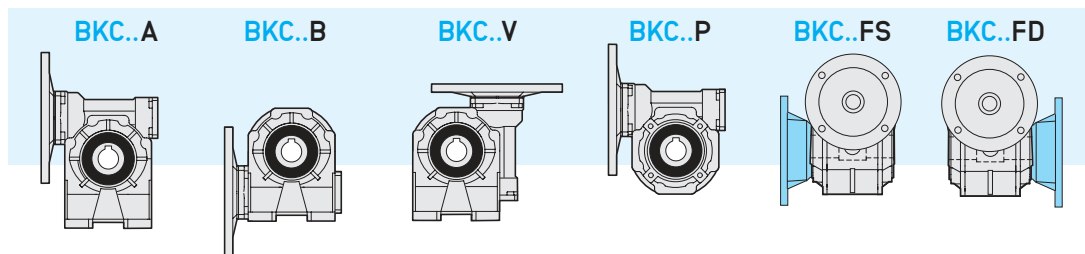

Per le dimensioni, gli accessori e le posizioni di montaggio vedere il "Catalogo dei Riduttori a Vite Senza Fine Tramec".

For dimensions, accessories and mounting positions see the "Tramec Worm Gearboxes Catalogue".

Informationen über Abmessungen, Ersatzteile und Montageposition sind in dem "Tramec Schneckengetriebekatalog".

Riduttori a vite
senza fine BSFK - BSRK



Worm gearboxes
BSFK - BSRK

Schneckengetriebe
BSFK - BSRK

Designazione

Designation

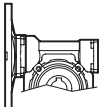
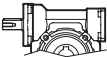
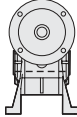
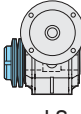
Bezeichnung

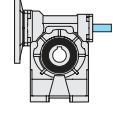
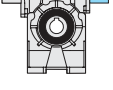
Riduttore Gearbox Getriebe	Grandezza Size Größe	Versione Version Ausführung	Flangia uscita Output flange Abtriebsflansch	Rapporto rid. Ratio Untersetzung	Predispos.att. mot. Motor coupling Motoranschluss	Albero uscita cavo Hollow output shaft Abtriebshohlwelle	Limitatore di coppia. Torque limiter Drehmoment- begrenzer	Seconda entrata Additional input Zusatzantrieb	Posizione di mont. Mounting position Einbaulage
BSFK	50	A	F1S	10	80 B14	H25	LD	SeA	B3
 BSFK  BSRK	30 40 50 63 75	A B V P	F...S F...D	5 7.5 10 15 20 25 30 40 50 65 80 100	56 ÷ 112 B5 56 ÷ 112 B14	vedi tabelle see tables siehe Tabellen 	 LS  LD	  SeA	B3 B6 B7 B8 V5 V6

Versioni

Versions

Ausführungen

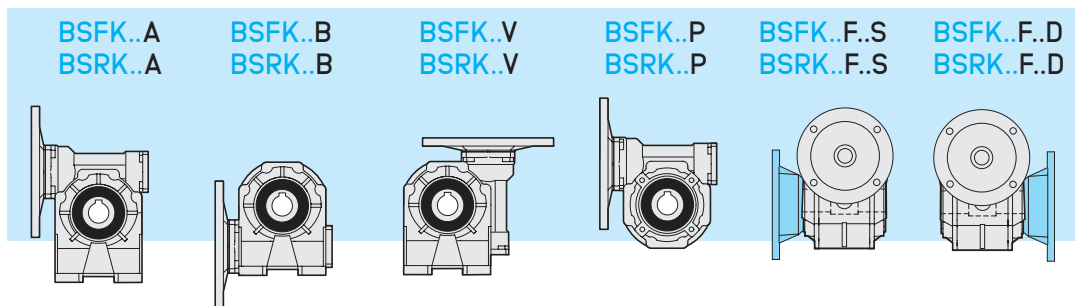

Per le dimensioni, gli accessori e le posizioni di montaggio vedere il "Catalogo dei Riduttori a Vite Senza Fine serie TLS".

For dimensions, accessories and mounting positions see the "Tramec Worm Gearboxes TLS serie Catalogue".

Informationen über Abmessungen, Ersatzteile und Montageposition sind in dem "Tramec Schneckengetriebekatalog Serie TLS".

Riduttori a vite
senza fine BBFK - BBRK

Worm gearboxes
BBFK - BBRK

Schneckengetriebe
BBFK - BBRK

Designazione

Designation

Bezeichnung

Riduttore Gearbox Getriebe	Grandezza Size Größe	Versione Version Ausführung	Flangia uscita Output flange Abtriebsflansch	Rapporto rid. Ratio Untersetzung	Predispos.att. mot. Motor coupling Motoranschluss	Albero uscita cavo Hollow output shaft Abtriebshohlwelle	Limitatore di coppia. Torque limiter Drehmoment- begrenzer	Seconda entrata Additional input Zusatzantrieb	Posizione di mont. Mounting position Einbaulage
BBFK	50	A	F1S	10	80 B14	H25	LD	SeA	B3
 BBFK BBRK	30 40 50 63 75	A B V P	F...S F...D	5 7.5 10 15 20 25 30 40 50 65 80 100	56 ÷ 112 B5 56 ÷ 112 B14	vedi tabelle see tables siehe Tabellen 	 LS LD	 SeA	B3 B6 B7 B8 V5 V6

Versioni

Versions

Ausführungen

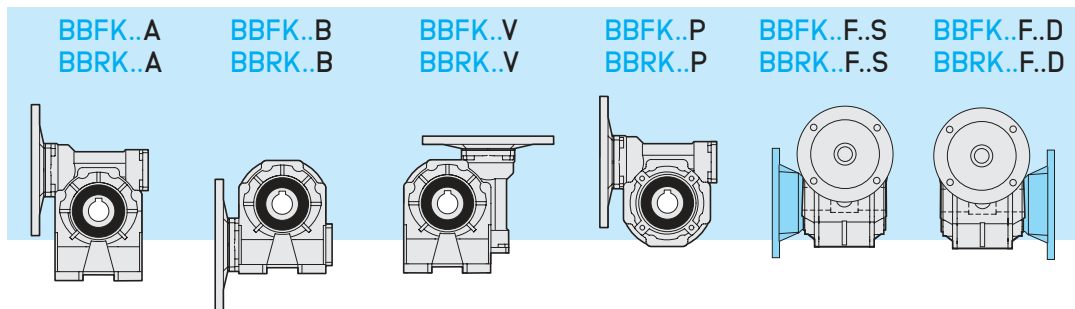

Per le dimensioni, gli accessori e le posizioni di montaggio vedere il "Catalogo dei Riduttori a Vite Senza Fine serie TLS".

For dimensions, accessories and mounting positions see the "Tramec Worm Gearboxes TLS serie Catalogue".

Informationen über Abmessungen, Ersatzteile und Montageposition sind in dem "Tramec Schneckengetriebekatalog Serie TLS".

Dati tecnici

Technical data

Technische Daten

BX BK BS..K BB..K	n ₁ = 1400 rpm			BXA BSRK - BBRK		BXC - BKC - BXF BSFK - BBFK				BXA - BXC - BKC - BXF BSFK - BSRK - BBFK - BBRK				
	i _n	R _d	n ₂	T _{2M}	P	T ₂	P ₁	F _{sa}	IEC		F _{R1}	F _{R2}	Classe / Class / Klasse [°C]	
	i _r		rpm	Nm	kW	Nm	kW		B...C	B...F	N	N	3G	3D
30	75	0.84	187	17	0.40	9	0.22	1.8	56 63	56 63	100	750	T4	130
	10	0.82	140	20	0.35	12	0.22	1.6				775		
	15	0.77	93	20	0.250	17	0.22	1.1				800		
	20	0.72	70	17	0.175	18	0.18	1.0				850		
	25	0.69	56	19	0.160	15	0.13	1.2				900		
	30	0.66	47	18	0.130	18	0.13	1.0				950		
	40	0.59	35	19	0.120	18	0.11	1.1				1000		
	50	0.55	28	17	0.091	17	0.09	1.0				1100		
	63	0.51	22	18	0.080	14	0.06	1.3				1200		
	80	0.48	18	14	0.055	-	-	-				1300		
100	0.45	14	13	0.040	-	-	-	1450						
40	75	0.85	187	30	0.70	24	0.55	1.3	63 71	56 63 71	220	1250	T4	130
	10	0.83	140	37	0.65	21	0.37	1.8				1250		
	15	0.79	93	30	0.37	30	0.37	1.0				1350		
	20	0.76	70	28	0.27	26	0.25	1.1				1500		
	25	0.72	56	25	0.20	22	0.18	1.1				1600		
	30	0.68	47	29	0.21	25	0.18	1.2				1700		
	40	0.64	35	26	0.15	23	0.13	1.2				1800		
	50	0.59	28	26	0.13	26	0.13	1.0				1950		
	65	0.54	22	24	0.10	22	0.09	1.1				2100		
	80	0.52	18	26	0.09	26	0.09	1.0				2300		
100	0.49	14	25	0.075	20	0.06	1.3	2300						
50	75	0.86	187	48	1.10	40	0.9	1.2	71 80	63 71 80	400	1400	T4	130
	10	0.84	140	52	0.90	52	0.9	1.0				1600		
	15	0.80	93	67	0.80	61	0.75	1.1				1900		
	20	0.78	70	68	0.63	59	0.55	1.2				2100		
	25	0.74	56	59	0.46	47	0.37	1.3				2500		
	30	0.71	47	61	0.42	54	0.37	1.1				2800		
	40	0.67	35	62	0.34	46	0.25	1.4				3000		
	50	0.62	28	63	0.30	53	0.25	1.2				3200		
	65	0.58	22	58	0.22	57	0.22	1.0				3200		
	80	0.54	18	54	0.18	53	0.18	1.0				3200		
100	0.51	14	50	0.14	43	0.13	1.1	3200						
63	75	0.87	187	76	1.70	67	1.5	1.1	80 90	71 80 90	480	1250	T4	130
	10	0.85	140	87	1.50	87	1.5	1.0				1700		
	15	0.81	93	122	1.45	91	1.1	1.3				1750		
	20	0.80	70	133	1.22	98	0.9	1.4				2000		
	25	0.77	56	105	0.80	98	0.75	1.1				2500		
	30	0.73	47	127	0.85	112	0.75	1.1				2700		
	40	0.69	35	131	0.70	104	0.55	1.3				3000		
	50	0.65	28	100	0.45	82	0.37	1.2				3250		
	65	0.61	22	100	0.37	68	0.37	1.5				3500		
	80	0.58	18	89	0.28	79	0.25	1.1				3700		
100	0.53	14	90	0.25	65	0.18	1.4	3900						
75	75	0.87	187	102	2.3	98	2.2	1.0	90 100	80 90 100	750	1900	T4	130
	10	0.86	140	123	2.1	106	1.8	1.2				2300		
	15	0.83	93	182	2.15	153	1.8	1.2				2500		
	20	0.81	70	203	1.80	166	1.5	1.2				3000		
	25	0.78	56	182	1.40	146	1.1	1.2				3200		
	30	0.74	47	198	1.30	167	1.1	1.2				3500		
	40	0.71	35	212	1.10	174	0.9	1.2				3800		
	50	0.67	28	190	0.83	171	0.75	1.1				4100		
	65	0.63	22	176	0.63	154	0.55	1.1				4400		
	80	0.60	18	180	0.55	180	0.55	1.0				4700		
100	0.56	14	146	0.385	-	-	-	4700						

Dati tecnici
Technical data
Technische Daten

BX BK BS..K BB..K	$n_1 = 1400 \text{ rpm}$			BXA BSRK - BBRK		BXC - BKC - BXF BSFK - BBFK				BXA - BXC - BKC - BXF BSFK - BSRK - BBFK - BBRK				
	i_n	R_d	n_2	T_{2M}	P	T_2	P_1	F_{sa}	IEC		F_{R1}	F_{R2}	Classe / Class / Klasse [°C]	
	i_r		rpm	Nm	kW	Nm	kW		B...C	B...F	N	N	3G	3D
89	7.5	0.88	187	122	2.70	99	2.2	1.2	90 100	-	-	2100	T4	130
	10	0.86	140	135	2.30	129	2.2	1.0				2500		
	15	0.84	93	288	3.35	155	1.8	1.9				2700		
	20	0.82	70	324	2.90	201	1.8	1.6				3500		
	25	0.80	56	300	2.20	205	1.5	1.5				3700		
	30	0.76	47	316	2.00	171	1.1	1.8				3900		
	40	0.72	35	339	1.73	216	1.1	1.6				4300		
	50	0.69	28	318	1.35	259	1.1	1.2				5000		
	65	0.65	22	286	1.00	259	0.9	1.1				5500		
	80	0.63	18	278	0.80	258	0.75	1.1				5800		
100	0.58	14	238	0.60	218	0.55	1.1	5800						
90	7.5	0.88	187	122	2.70	99	2.2	1.2	90 100	80 90 100	850	2100	T4	130
	10	0.86	140	135	2.30	129	2.2	1.0				2500		
	15	0.84	93	288	3.35	155	1.8	1.9				2700		
	20	0.82	70	324	2.90	201	1.8	1.6				3500		
	25	0.80	56	300	2.20	205	1.5	1.5				3700		
	30	0.76	47	316	2.00	171	1.1	1.8				3900		
	40	0.72	35	339	1.73	216	1.1	1.6				4300		
	50	0.69	28	318	1.35	259	1.1	1.2				5000		
	65	0.65	22	286	1.00	259	0.9	1.1				5500		
	80	0.63	18	278	0.80	258	0.75	1.1				5800		
100	0.58	14	238	0.60	218	0.55	1.1	5800						
110	7.5	0.88	187	180	4.00	180	4.0	1.0	100 112 132	80 90 100 112 132	1200	1400	T4	130
	10	0.87	140	479	3.70	178	3.0	2.7				2700		
	15	0.84	93	516	6.00	258	3.0	2.0				3600		
	20	0.83	70	561	5.00	249	2.2	2.3				4500		
	25	0.81	56	520	3.75	344	2.2	1.7				5000		
	30	0.77	47	541	3.43	284	1.8	1.9				5400		
	40	0.74	35	618	3.00	363	1.8	1.7				6300		
	50	0.72	28	578	2.35	368	1.5	1.6				6900		
	65	0.68	22	502	1.68	452	1.5	1.1				7500		
	80	0.65	18	426	1.28	390	1.1	1.2				8000		
100	0.61	14	458	1.10	458	1.1	1.0	8000						
130	7.5	0.89	187	259	5.70	250	5.5	1.0	100 112 132	90 100 112 132	1500	2700	T4	130
	10	0.88	140	312	5.20	240	4.0	1.3				3900		
	15	0.85	93	770	8.82	349	4.0	2.2				4700		
	20	0.84	70	877	7.65	344	3.0	2.6				5000		
	25	0.83	56	828	5.85	425	3.0	2.0				6500		
	30	0.79	47	852	5.31	482	3.0	1.8				6500		
	40	0.76	35	933	4.50	456	2.2	2.0				7000		
	50	0.74	28	863	3.42	555	2.2	1.6				8000		
	65	0.71	22	721	2.34	555	1.8	1.3				8800		
	80	0.68	16	685	1.90	649	1.8	1.1				9500		
100	0.64	14	699	1.45	655	1.5	1.1	10050						

Riduttori a vite
senza fine con precoppia BH







Helical worm
gearboxes BH

Stirnrad-
Schneckengetriebe BH

Designazione

Designation

Bezeichnung

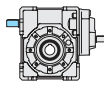
Riduttore Gearbox Getriebe	Tipo entrata Input type Antriebsart	Grandezza Size Größe	Rapporto rid. Ratio Untersetzung	Predispos.att. mot. Motor coupling Motoranschluss	Albero uscita cavo Hollow output shaft Abtriebshohlwelle	Flangia in uscita. Output flange Abtriebsflansch	Seconda entrata Additional input Zusatzantrieb	Posizione di mont. Mounting position Einbaulage
BH	A	50	30/1	P.A.M	H25	F1S	SeA	B3
Riduttore a vite senza fine Wormgearbox Schneckengetriebe	 A  F	40 50 63 75 90 110 130	30 40 60 80 100 120 160 200 260 320 400	56 63 71 80 90 100 112	vedi tabelle see tables siehe Tabellen 	 F1D-F2D-F3D  F1S-F2S-F3S  F12-F22-F32	 SeA	B3, B6 B7, B8 V5, V6

Tipo entrata

Input type

Antriebstyp

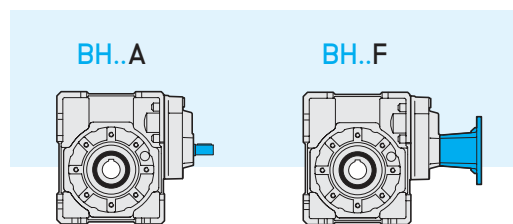

Per le dimensioni, gli accessori e le posizioni di montaggio vedere il "Catalogo dei Riduttori a Vite Senza Fine Tramec".

For dimensions, accessories and mounting positions see the "Tramec Worm Gearboxes Catalogue".

Informationen über Abmessungen, Ersatzteile und Montageposition sind in dem "Tramec Schneckengetriebe-katalog".

Dati tecnici
Technical data
Technische Daten

BH	n ₁ = 1400 rpm			BHA		BHF				BHA - BHF			
	i _n	R _d	n ₂ rpm	T _{2M} Nm	P kW	T ₂ Nm	P ₁ kW	F _{sa}	B...F	F _{R1} N	F _{R2} N	Classe / Class / Klasse [°C] 3G 3D	
40	30	0.77	47	59	0.37	35	0.22	1.7	56 63	150	1500	T4	130
	40	0.75	35	59	0.29	45	0.22	1.3			1700		
	60	0.69	23	56	0.20	51	0.18	1.1			1800		
	80	0.66	18	54	0.15	40	0.11	1.4			1900		
	100	0.61	14	47	0.11	37	0.09	1.2			2000		
	120	0.57	12	59	0.12	61	0.13	1.0			2500		
	160	0.52	9	56	0.10	51	0.09	1.1			2500		
	200	0.47	7	52	0.08	38	0.06	1.4			2500		
	260	0.43	5	41	0.05	-	-	-			2500		
	320	0.41	4	40	0.04	-	-	-			2500		
400	0.47	3.5	30	0.03	-	-	-	2500					
50	30	0.79	47	102	0.63	89	0.55	1.1	56 63 71	230	2300	T4	130
	40	0.76	35	104	0.50	77	0.37	1.4			2700		
	60	0.71	23	104	0.35	73	0.25	1.4			2900		
	80	0.68	18	103	0.27	93	0.25	1.1			2900		
	100	0.63	14	87	0.20	77	0.18	1.1			3000		
	120	0.59	12	96	0.20	87	0.18	1.1			3500		
	160	0.55	9	104	0.20	78	0.13	1.3			3500		
	200	0.50	7	92	0.17	75	0.11	1.2			3500		
	260	0.46	5	81	0.13	73	0.09	1.1			3500		
	320	0.42	4	72	0.09	55	0.06	1.4			3500		
400	0.40	3.5	59	0.05	-	-	-	3500					
63	30	0.79	47	178	1.10	146	0.9	1.2	63 71 80	320	2500	T4	130
	40	0.77	35	183	0.87	158	0.75	1.2			2700		
	60	0.72	23	183	0.62	162	0.55	1.1			3500		
	80	0.70	18	190	0.50	141	0.37	1.3			4500		
	100	0.67	14	163	0.35	114	0.25	1.4			5000		
	120	0.61	12	192	0.38	125	0.25	1.5			5000		
	160	0.57	9	198	0.32	156	0.25	1.3			5000		
	200	0.52	7	159	0.22	128	0.18	1.2			5000		
	260	0.48	5	158	0.18	111	0.13	1.4			5000		
	320	0.46	4	144	0.14	131	0.13	1.1			5000		
400	0.44	3.5	113	0.10	-	-	-	5000					
75	30	0.80	47	266	1.62	246	1.5	1.1	71 80 90	570	3400	T4	130
	40	0.78	35	287	1.35	234	1.1	1.2			4350		
	60	0.73	23	296	1.00	269	0.9	1.1			5000		
	80	0.71	18	315	0.81	291	0.75	1.1			5750		
	100	0.68	14	275	0.59	255	0.55	1.1			5750		
	120	0.62	12	298	0.58	279	0.55	1.1			5750		
	160	0.58	9	313	0.51	234	0.37	1.3			5750		
	200	0.55	7	276	0.37	278	1.1	1.0			5750		
	260	0.50	5	251	0.28	222	0.25	1.1			5750		
	320	0.47	4	230	0.22	256	0.25	1.0			5750		
400	0.43	3.5	192	0.16	-	-	-	5750					

Dati tecnici
Technical data
Technische Daten

BH	$n_1 = 1400 \text{ rpm}$			BHA		BHF				BHA - BHF			
	i_n	R_d	n_2 rpm	T_{2M} Nm	P kW	T_2 Nm	P_1 kW	F_{sa}	B...F	F_{R1} N	F_{R2} N	Classe / Class / Klasse [°C] 3G 3D	
90	30	0.81	47	348	2.10	298	1.8	1.5	71 80 90	570	5000	T4	130
	40	0.79	35	446	2.10	323	1.5	1.4			5100		
	60	0.75	23	455	1.50	460	1.5	1.0			5500		
	80	0.72	18	499	1.26	432	1.1	1.2			5900		
	100	0.70	14	455	0.95	430	0.9	1.1			6950		
	120	0.64	12	478	0.91	471	0.9	1.0			7000		
	160	0.60	9	504	0.77	491	0.75	1.0			7000		
	200	0.57	7	459	0.59	428	0.55	1.1			7000		
	260	0.53	5	409	0.43	348	0.37	1.2			7000		
	320	0.50	4	382	0.35	273	0.25	1.4			7000		
400	0.45	3.5	330	0.27	307	0.25	1.1	7000					
110	30	0.82	47	537	3.20	503	3	1.1	80 80 100 112	800	6000	T4	130
	40	0.80	35	784	2.90	655	3	1.2			6100		
	60	0.76	23	560	2.50	560	1.8	1.0			7000		
	80	0.74	18	909	2.25	888	2.2	1.0			7200		
	100	0.72	14	884	1.80	884	1.5	1.2			7700		
	120	0.66	12	870	1.60	810	1.5	1.1			8000		
	160	0.62	9	812	1.20	744	1.1	1.1			8000		
	200	0.60	7	819	1.00	737	0.9	1.1			8000		
	260	0.55	5	732	0.75	732	0.75	1.0			8000		
	320	0.52	4	686	0.60	624	0.55	1.1			8000		
400	0.47	3.5	705	0.55	705	0.55	1.0	8000					
130	30	0.83	47	776	4.60	675	4	1.2	80 80 100 112	1000	6000	T4	130
	40	0.81	35	906	4.10	884	4	1.0			6100		
	60	0.77	23	1087	3.40	959	3	1.1			7000		
	80	0.75	18	1234	3.10	1194	3	1.0			7200		
	100	0.74	14	1413	2.50	1111	1.8	1.3			7700		
	120	0.68	12	1299	2.34	1191	1.5	1.1			8000		
	160	0.65	9	1517	1.98	1517	1.1	1.0			8000		
	200	0.62	7	1353	1.44	1269	0.9	1.1			8000		
	260	0.58	5	1219	0.99	1219	0.75	1.0			8000		
	320	0.55	4	1182	0.810	985	0.55	1.2			8000		
400	0.51	3.5	1141	0.735	1044	0.55	1.1	8000					

Designazione

Designation

Bezeichnung

Riduttore entrata Gearbox at input Getriebe am Antrieb	Macchina uscita Gearbox at output Getriebe am Abtrieb	Tipo entrata Input type	Antriebsart	Grandezza Size Größe	Versione Version Version	Rapporto rid. Ratio Untersetzung	Predispos.att. mot. Motor coupling Motoranschluss	Albero uscita cavo Hollow output shaft Abtriebshohlwelle	Flangia uscita Output flange Abtriebshohlwelle	Limitatore di coppia. Torque limiter Drehmomentbegrenzer	Seconda entrata Additional input Zusatzantrieb	Forma costruttiva Execution Bauform	Posizione di mont. Mounting position Einbaulage
BK	K	C	50/110	F1	1200	P.A.M.	H42	F1S	LD	SeA1	a	B3	
Riduttore a vite senza fine combinato Combined worm gearbox Doppelschneckengetriebe				30/30 30/40 30/50 30/63 40/63 40/75 40/89 40/90 50/75 50/89 50/90 50/110 63/110 63/130	P F (1-2-3) A (1-2) B (1-2) V (1-2)	150 200 300 450 600 900 1200 1500 1950 2500 3250 4000 5000 10000	56 63 71 80 90		F1S-F2S F3S F1D-F2D F3D	 LD LS	 SeA1 SeA2	ab cd ef gh ik im no pq	B3 B6 B7 B8 V5 V6

Versioni

Versions

Ausführungen

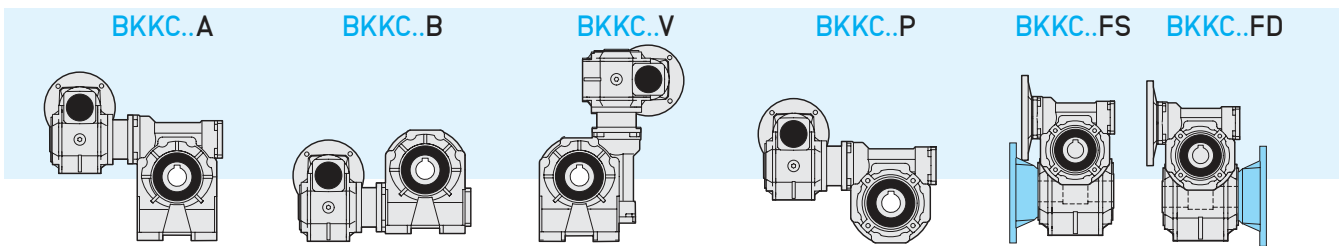

Per le dimensioni, gli accessori e le posizioni di montaggio vedere il "Catalogo dei Riduttori a Vite Senza Fine Tramec".

For dimensions, accessories and mounting positions see the "Tramec Worm Gearboxes Catalogue".

Informationen über Abmessungen, Ersatzteile und Montageposition sind in dem "Tramec Schneckengetriebe-katalog".

Riduttori a vite
senza fine combinati BKXC



Combined worm
gearboxes BKXC

Kombinierte
Schneckengetriebe BKXC

Designazione

Designation

Bezeichnung

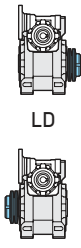
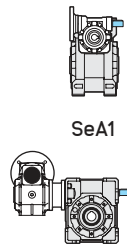
Riduttore entrata Gearbox at input Getriebe am Antrieb	Macchina uscita Gearbox at output Getriebe am Abtrieb	Tipo entrata Input type Antriebsart	Grandezza Size Größe	Versione Version Version	Rapporto rid. Ratio Untersetzung	Predispos. att. mot. Motor coupling Motoranschluss	Albero uscita cavo Hollow output shaft Abtriebshohlwelle	Flangia uscita Output flange Abtriebsflansch	Limitatore di coppia. Torque limiter Drehmoment- begrenzer	Seconda entrata Additional input Zusatzantrieb	Forma costruttiva Execution Bauform	Posizione di mont. Mounting position Einbaulage
BK	X	C	50/110	F1	1200	P.A.M.	H42	F1S	LD	SeA1	a	B3
Riduttore a vite senza fine combinato Combined worm gearbox Doppelschneckengetriebe		 C	30/30 30/40 30/50 30/63 40/63 40/75 40/89 40/90 50/75 50/89 50/90 50/110 63/110 63/130	P F (1-2-3)	150 200 300 450 600 900 1200 1500 1950 2500 3250 4000 5000 10000	56 63 71 80 90	vedi tabelle see tables siehe Tabellen 	F1S-F2S F3S F1D-F2D F3D	 LD LS	 SeA1 SeA2	ab cd ef gh ik im no pq	B3 B6 B7 B8 V5 V6

Tipo entrata

Input type

Antriebstyp

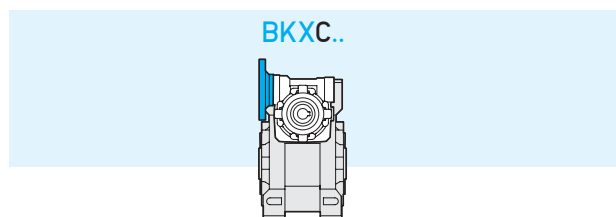

Per le dimensioni, gli accessori e le posizioni di montaggio vedere il "Catalogo dei Riduttori a Vite Senza Fine Tramec".

For dimensions, accessories and mounting positions see the "Tramec Worm Gearboxes Catalogue".

Informationen über Abmessungen, Ersatzteile und Montageposition sind in dem "Tramec Schneckengetriebekatalog".

Riduttori a vite
senza fine combinati BKKC





Combined worm
gearboxes BKKC

Kombinierte
Schneckengetriebe BKKC

Designazione

Designation

Bezeichnung

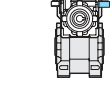
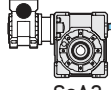
Riduttore entrata Gearbox at input Getriebe am Antrieb	Macchina uscita Gearbox at output Getriebe am Abtrieb	Tipo entrata Input type Antriebsart	Grandezza Size Größe	Versione Version Version	Rapporto rid. Ratio Untersetzung	Predispos. att. mot. Motor coupling Motoranschluss	Albero uscita cavo Hollow output shaft Abtriebshohlwelle	Flangia uscita Output flange Abtriebssflansch	Limitatore di coppia. Torque limiter Drehmoment- begrenzer	Seconda entrata Additional input Zusatzantrieb	Forma costruttiva Execution Bauform	Posizione di mont. Mounting position Einbaulage
BX	X	C	50/110	F1	1200	P.A.M.	H42	F1S	LD	SeA1	a	B3
Riduttore a vite senza fine combinato Combined worm gearbox Doppelschneckengetriebe 			30/30 30/40 30/50 30/63 40/63 40/75 40/89 40/90 50/75 50/89 50/90 50/110 63/110 63/130	P F (1-2-3)	150 200 300 450 600 900 1200 1500 1950 2500 3250 4000 5000 10000	56 63 71 80 90	vedi tabelle see tables Tabellen 	F1S-F2S F3S F1D-F2D F3D  LD  LS	 SeA1  SeA2	ab cd ef gh ik im no pq	B3 B6 B7 B8 V5 V6	

Tipo entrata

Input type

Antriebstyp

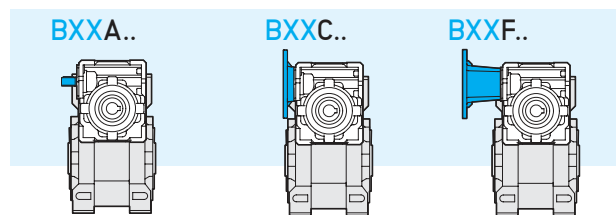

Per le dimensioni, gli accessori e le posizioni di montaggio vedere il "Catalogo dei Riduttori a Vite Senza Fine Tramec".

For dimensions, accessories and mounting positions see the "Tramec Worm Gearboxes Catalogue".

Informationen über Abmessungen, Ersatzteile und Montageposition sind in dem "Tramec Schneckengetriebe-katalog".

Riduttori a vite
senza fine combinati BSC..K

Combined worm
gearboxes BSC..K

Kombinierte
Schneckengetriebe BSC..K

Designazione

Designation

Bezeichnung

Riduttore Gearbox Getriebe	Grandezza Size Größe	Versione Version Version	Flangia uscita Output flange Abtriebsflansch	Rapporto rid. Ratio Untersetzung	Predispos.att. mot. Motor coupling Motoranschluss	Albero uscita cavo Hollow output shaft Abtriebshohlwelle	Limitatore di coppia. Torque limiter Drehmoment- begrenzer	Seconda entrata Additional input Zusatzantrieb	Forma costruttiva Execution Bauform	Posizione di mont. Mounting position Einbaulage
BSCFK	50/75	A	F1S	1200	P.A.M.	H25	LD	SeA1	a	B3
	30/30 30/40 30/50 30/63 40/63 40/75 50/75	A B V P	F...S F...D	150 200 300 450 600 900 1200 1500 1950 2500 3250 4000 5000 10000	56 63 71 80 90	vedi tabelle see tables siehe Tabellen	 LD	 SeA1	ab cd ef gh ik im no pq	B3 B6 B7 B8 V5 V6
							 LS	 SeA2		

Versioni

Versions

Ausführungen

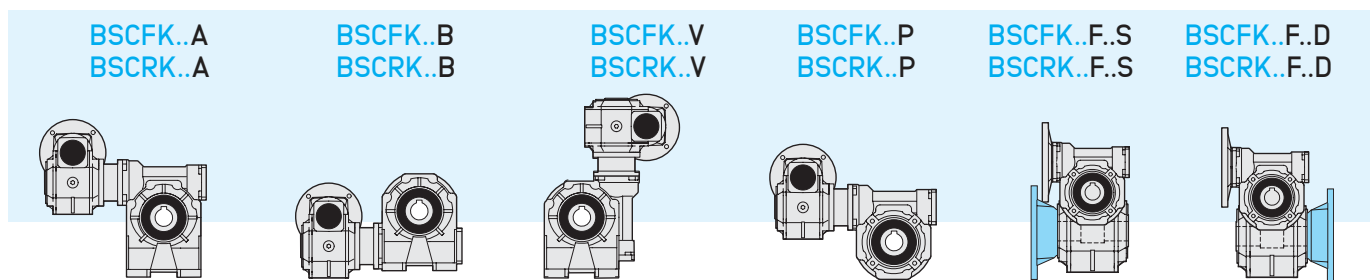

Per le dimensioni, gli accessori e le posizioni di montaggio vedere il "Catalogo dei Riduttori a Vite Senza Fine serie TLS".

For dimensions, accessories and mounting positions see the "Tramec Worm Gearboxes TLS serie Catalogue".

Informationen über Abmessungen, Ersatzteile und Montageposition sind in dem "Tramec Schneckengetriebekatalog Serie TLS".

Designazione

Designation

Bezeichnung

Riduttore Gearbox Getriebe	Grandezza Size Größe	Versione Version Version	Flangia uscita Output flange Abtriebflansch	Rapporto rid. Ratio Untersetzung	Predispos.att. mot. Motor coupling Motoranschluss	Albero uscita cavo Hollow output shaft Abtriebhohlwelle	Limitatore di coppia. Torque limiter Drehmoment- begrenzer	Seconda entrata Additional input Zusatzeintrieb	Forma costruttiva Execution Bauform	Posizione di mont. Mounting position Einbaulage
BBCFK	50/75	A	F1S	1200	P.A.M.	H25	LD	SeA1	a	B3
 BBCFK BBCRK	30/30 30/40 30/50 30/63 40/63 40/75 50/75	A B V P	F...S F...D	150 200 300 450 600 900 1200 1500 1950 2500 3250 4000 5000 10000	56 63 71 80 90	vedi tabelle see tables siehe Tabellen	 LD LS	 SeA1 SeA2	ab cd ef gh ik im no pq	B3 B6 B7 B8 V5 V6

Versioni

Versions

Ausführungen

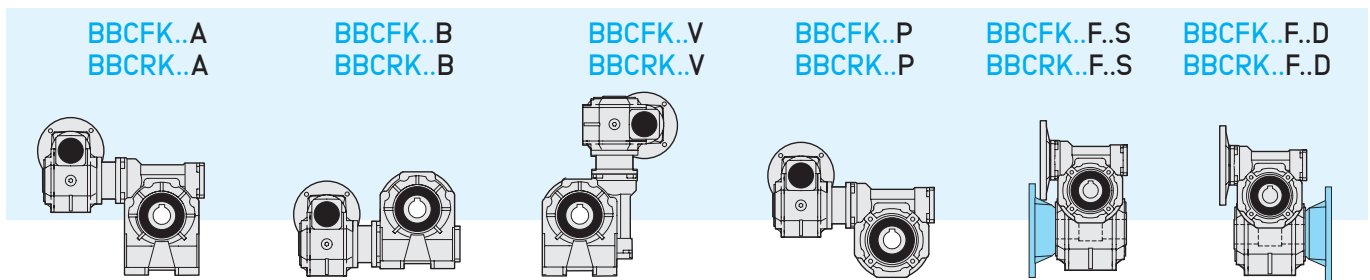

Per le dimensioni, gli accessori e le posizioni di montaggio vedere il "Catalogo dei Riduttori a Vite Senza Fine serie TLS".

For dimensions, accessories and mounting positions see the "Tramec Worm Gearboxes TLS serie Catalogue".

Informationen über Abmessungen, Ersatzteile und Montageposition sind in dem "Tramec Schneckengetriebekatalog Serie TLS".

Dati tecnici

Technical data

Technische Daten

30/30	$n_1 = 1400$				BXXA BSCRK - BBCRK		BKXC - BXXC - BXXF - BKKC BSCFK - BBCFK					BKXC - BXX.. - BKKC BSC..K - BBC..K								
	i_n	30	30	n_2	Rd	T_{2M}	P	T_2	P_1	FS'	Input - IEC						Classe / Class / Klasse [°C]			
		i_1	i_2								BKXC - BXXC - BKKC BSCFK - BBCFK		BXXF		3G	3D				
											B5/B14	B5	B14							
150	10	15	9.3	0.51	37	0.070	32	0.06	1.2	-	63	56	-	63	56	-	63	56	T4	130
200		20	7.0	0.47	32	0.050	39	0.06	0.8											
300				4.7	0.42	39	0.045	52*	0.06											
450	15		3.1	0.40	39	0.032	73*	0.06	0.5*											
600	20		2.3	0.37	39	0.026	91*	0.06	0.4*											
900	30	30	1.6	0.34	39	0.019	125*	0.06	0.3*											
1200	40		1.2	0.30	39	0.016	149*	0.06	0.3*											
1500	50		0.9	0.28	39	0.014	173*	0.06	0.2*											
1950	65		0.7	0.26	39	0.011	209*	0.06	0.2*											
2500	50	50	0.6	0.23	30	0.008	235*	0.06	0.1*											
3250	65		0.4	0.21	30	0.006	283*	0.06	0.11*											
4000	80		0.4	0.20	30	0.005	328*	0.06	0.09*											
5000	100		0.3	0.19	30	0.005	385*	0.06	0.08*											
10000		100	0.1	0.15	17	0.002	609*	0.06	0.03*											

30/40	$n_1 = 1400$				BXXA BSCRK - BBCRK		BKXC - BXXC - BXXF - BKKC BSCFK - BBCFK					BKXC - BXX.. - BKKC BSC..K - BBC..K								
	i_n	30	40	n_2	Rd	T_{2M}	P	T_2	P_1	FS'	Input - IEC						Classe / Class / Klasse [°C]			
		i_1	i_2								BKXC - BXXC - BKKC BSCFK - BBCFK		BXXF		3G	3D				
											B5/B14	B5	B14							
150	10	15	9.3	0.54	82	0.148	72	0.13	1.1	-	63	56	-	63	56	-	63	56	T4	130
200		20	7.0	0.51	76	0.110	76	0.11	1.0											
300				4.7	0.43	82	0.094	79	0.09											
450	15		3.1	0.40	82	0.067	74	0.06	1.1											
600	20		2.3	0.37	82	0.054	92	0.06	0.9											
900	30	30	1.6	0.34	82	0.039	126*	0.06	0.6*											
1200	40		1.2	0.31	82	0.033	151*	0.06	0.5*											
1500	50		0.9	0.29	82	0.028	176*	0.06	0.5*											
1950	65		0.7	0.27	82	0.023	212*	0.06	0.4*											
2500	50	50	0.6	0.23	68	0.017	236*	0.06	0.3*											
3250	65		0.4	0.21	68	0.014	285*	0.06	0.24*											
4000	80		0.4	0.20	68	0.012	330*	0.06	0.21*											
5000	100		0.3	0.19	68	0.011	387*	0.06	0.18*											
10000		100	0.1	0.15	35	0.003	626*	0.06	0.06*											

30/50	$n_1 = 1400$				BXXA BSCRK - BBCRK		BKXC - BXXC - BXXF - BKKC BSCFK - BBCFK					BKXC - BXX.. - BKKC BSC..K - BBC..K								
	i_n	30	50	n_2	Rd	T_{2M}	P	T_2	P_1	FS'	Input - IEC						Classe / Class / Klasse [°C]			
		i_1	i_2								BKXC - BXXC - BKKC BSCFK - BBCFK		BXXF		3G	3D				
											B5/B14	B5	B14							
150	10	15	9.3	0.55	149	0.265	124	0.22	1.2	-	63	56	-	63	56	-	63	56	T4	130
200		20	7.0	0.52	144	0.201	129	0.18	1.1											
300				4.7	0.44	150	0.166	118	0.13											
450	15		3.1	0.42	150	0.118	140	0.11	1.1											
600	20		2.3	0.39	150	0.094	143	0.09	1.0											
900	30	30	1.6	0.36	150	0.069	131	0.06	1.1											
1200	40		1.2	0.32	150	0.058	156	0.06	1.0											
1500	50		0.9	0.30	150	0.049	182	0.06	0.8											
1950	65		0.7	0.28	150	0.041	220*	0.06	0.7*											
2500	50	50	0.6	0.25	125	0.030	253*	0.06	0.5*											
3250	65		0.4	0.23	125	0.025	305*	0.06	0.41*											
4000	80		0.4	0.22	125	0.021	354*	0.06	0.35*											
5000	100		0.3	0.20	125	0.018	414*	0.06	0.30*											
10000		100	0.1	0.16	69	0.006	645*	0.06	0.11*											

* ATTENZIONE: la coppia massima utilizzabile $[T_{2M}]$ deve essere calcolata utilizzando il fattore di servizio:
 $T_{2M} = T_2 \times FS'$

* WARNING: Maximum allowable torque $[T_{2M}]$ must be calculated using the following service factor:
 $T_{2M} = T_2 \times FS'$

* ACHTUNG: das max. anwendbare Drehmoment $[T_{2M}]$ muss mit folgendem Betriebsfaktor berechnet werden:
 $T_{2M} = T_2 \times FS'$

Dati tecnici

Technical data

Technische Daten

	$n_1 = 1400$					BXXA BSCRK - BBCRK		BKXC - BXXC - BXXF - BKKC BSCFK - BBCFK						BKXC - BXX.. - BKKC BSC..K - BBC..K								
	i_n	30	63	n_2	Rd	T_{2M}	P	T_2	P_1	FS'	Input - IEC						Classe / Class / Klasse [°C]					
		i_1	i_2								BKXC - BXXC - BKKC BSCFK - BBCFK		BXXF		3G		3D					
				B5/B14	B5	B14																
30/63	150	10	15	9.3	0.56	228	0.400	126	0.22	1.8	-	63	56	-	63	56	-	63	56	T4	130	
	200		20	7.0	0.54	279	0.378	162	0.22	1.7												
	300			4.7	0.46	268	0.285	207	0.22	1.3												
	450	15		3.1	0.43	268	0.202	238	0.18	1.1												
	600		20	2.3	0.40	268	0.162	215	0.13	1.2												
	900	30	30	1.6	0.37	268	0.118	250	0.11	1.1												
	1200		40	1.2	0.33	268	0.099	243	0.09	1.1												
	1500		50	0.9	0.31	268	0.085	189	0.06	1.4												
	1950	65		0.7	0.29	268	0.071	228	0.06	1.2												
	2500	50		0.6	0.26	222	0.050	265	0.06	0.8												
	3250		65	0.4	0.24	222	0.042	319*	0.06	0.70*												
	4000		80	0.4	0.23	222	0.036	369*	0.06	0.60*												
	5000	100		0.3	0.21	222	0.031	433*	0.06	0.51*												
	10000		100	0.1	0.16	138	0.012	663*	0.06	0.21*												
40/63	150	10	15	9.3	0.56	261	0.452	214	0.37	1.2	71	-	-	-	-	-	-	-	-	-	T4	130
	200		20	7.0	0.55	279	0.373	277	0.37	1.0												
	300			4.7	0.46	268	0.282	238	0.25	1.1												
	450	15		3.1	0.44	268	0.197	244	0.18	1.1												
	600		20	2.3	0.43	268	0.154	226	0.13	1.2												
	900	30	30	1.6	0.38	268	0.115	257	0.11	1.0												
	1200		40	1.2	0.36	268	0.091	264	0.09	1.0												
	1500		50	0.9	0.33	268	0.079	203	0.06	1.3												
	1950	65		0.7	0.30	268	0.067	241	0.06	1.1												
	2500	50		0.6	0.28	222	0.047	284	0.06	0.8												
	3250		65	0.4	0.25	222	0.039	338*	0.06	0.66*												
	4000		80	0.4	0.24	222	0.033	400*	0.06	0.55*												
	5000	100		0.3	0.23	222	0.028	471*	0.06	0.47*												
	10000		100	0.1	0.18	138	0.011	722*	0.06	0.19*												
40/75	150	10	15	9.3	0.57	409	0.698	322	0.55	1.3	71	-	-	-	-	-	-	-	-	-	T4	130
	200		20	7.0	0.56	442	0.583	417	0.55	1.1												
	300			4.7	0.47	418	0.432	358	0.37	1.2												
	450	15		3.1	0.45	418	0.302	346	0.25	1.2												
	600		20	2.3	0.43	418	0.236	390	0.22	1.1												
	900	30	30	1.6	0.39	418	0.176	309	0.13	1.4												
	1200		40	1.2	0.36	418	0.140	388	0.13	1.1												
	1500		50	0.9	0.34	418	0.121	379	0.11	1.1												
	1950	65		0.7	0.31	418	0.102	368	0.09	1.1												
	2500	50		0.6	0.29	381	0.077	296	0.06	1.3												
	3250		65	0.4	0.26	381	0.065	352	0.06	1.08												
	4000		80	0.4	0.25	381	0.055	417	0.06	0.91												
	5000	100		0.3	0.24	381	0.047	491*	0.06	0.78*												
	10000		100	0.1	0.19	232	0.018	762*	0.06	0.30*												

* ATTENZIONE: la coppia massima utilizzabile $[T_{2M}]$ deve essere calcolata utilizzando il fattore di servizio:
 $T_{2M} = T_2 \times FS'$

* WARNING: Maximum allowable torque $[T_{2M}]$ must be calculated using the following service factor:
 $T_{2M} = T_2 \times FS'$

* ACHTUNG: das max. anwendbare Drehmoment $[T_{2M}]$ muss mit folgendem Betriebsfaktor berechnet werden:
 $T_{2M} = T_2 \times FS'$

Dati tecnici

Technical data

Technische Daten

50/75	n ₁ = 1400				BXXA BSCRK - BBCRK		BKXC - BXXC - BXXF - BKKC BSCFK - BBCFK					BKXC - BXX.. - BKKC BSC..K - BBC..K														
	i _n	50 i ₁	75 i ₂	n ₂ [min ⁻¹]	Rd	T _{2M} [Nm]	P [kW]	T ₂ [Nm]	P ₁ [kW]	FS'	Input - IEC						Classe / Class / Klasse [°C]									
											BKXC - BXXC - BKKC BSCFK - BBCFK			BXXF			3G	3D								
	B5/B14			B5			B14																			
150	10	15	9.3	0.57	409	0.750	409	0.75	1.0	80	-															
200			20	7.0	0.56	442	0.576	422	0.55										1.0							
300			30	4.7	0.48	418	0.427	363	0.37										1.2							
450	3.1	0.46		418	0.299	350	0.25	1.2																		
600	2.3	0.42		418	0.250	418	0.25	1.0																		
900	1.6	0.40		418	0.180	418	0.18	1.0																		
1200	40	1.2	0.38	418	0.134	406	0.13	1.0	71																	
1500	50	0.9	0.35	418	0.116	470	0.13	0.9																		
1950	65	0.7	0.33	418	0.095	572*	0.13	0.7*	-										63							
2500	50	0.6	0.30	381	0.074	674*	0.13	0.6*																		
3250	65	0.4	0.28	381	0.060	819*	0.13	0.47*																		
4000	80	0.4	0.26	381	0.053	939*	0.13	0.41*																		
5000	100	0.3	0.25	381	0.045	1108*	0.13	0.34*																		
10000		100	0.1	0.19	232	0.018	1719*	0.13		0.13*																

40/89	n ₁ = 1400				BXXA BSCRK - BBCRK		BKXC - BXXC - BXXF - BKKC BSCFK - BBCFK					BKXC - BXX.. - BKKC BSC..K - BBC..K														
	i _n	40 i ₁	90 i ₂	n ₂ [min ⁻¹]	Rd	T _{2M} [Nm]	P [kW]	T ₂ [Nm]	P ₁ [kW]	FS'	Input - IEC						Classe / Class / Klasse [°C]									
											BKXC - BXXC - BKKC BSCFK - BBCFK			BXXF			3G	3D								
	B5/B14			B5			B14																			
150	10	15	9.3	0.58	392	0.659	327	0.55	1.2	71	-															
200			20	7.0	0.56	504	0.654	424	0.55										1.2							
300			30	4.7	0.48	606	0.615	542	0.55										1.1							
450	3.1	0.46		606	0.430	520	0.37	1.2																		
600	2.3	0.44		606	0.336	457	0.25	1.3																		
900	1.6	0.39		606	0.250	605	0.25	1.0																		
1200	40	1.2	0.37	606	0.199	668	0.22	0.9	63																	
1500	50	0.9	0.34	594	0.169	630	0.18	0.9																		
1950	65	0.7	0.31	558	0.134	542	0.13	1.0	-										56							
2500	50	0.6	0.30	571	0.112	564	0.11	1.0																		
3250	65	0.4	0.28	571	0.094	549	0.09	1.0																		
4000	80	0.4	0.27	571	0.079	651	0.09	0.88																		
5000	100	0.3	0.25	571	0.067	767*	0.09	0.74*																		
10000		100	0.1	0.19	361	0.028	1173*	0.09		0.31*																

40/90	n ₁ = 1400				BXXA BSCRK - BBCRK		BKXC - BXXC - BXXF - BKKC BSCFK - BBCFK					BKXC - BXX.. - BKKC BSC..K - BBC..K														
	i _n	40 i ₁	90 i ₂	n ₂ [min ⁻¹]	Rd	T _{2M} [Nm]	P [kW]	T ₂ [Nm]	P ₁ [kW]	FS'	Input - IEC						Classe / Class / Klasse [°C]									
											BKXC - BXXC - BKKC BSCFK - BBCFK			BXXF			3G	3D								
	B5/B14			B5			B14																			
150	10	15	9.3	0.58	435	0.732	327	0.55	1.3	71	-															
200			20	7.0	0.56	560	0.727	424	0.55										1.3							
300			30	4.7	0.48	673	0.683	542	0.55										1.2							
450	3.1	0.46		673	0.478	520	0.37	1.3																		
600	2.3	0.44		673	0.373	668	0.37	1.0																		
900	1.6	0.39		673	0.278	605	0.25	1.1																		
1200	40	1.2	0.37	673	0.221	668	0.22	1.0	63																	
1500	50	0.9	0.34	660	0.188	630	0.18	1.0																		
1950	65	0.7	0.31	620	0.149	542	0.13	1.1	-										56							
2500	50	0.6	0.30	634	0.124	564	0.11	1.1																		
3250	65	0.4	0.28	634	0.104	549	0.09	1.2																		
4000	80	0.4	0.27	634	0.088	651	0.09	0.97																		
5000	100	0.3	0.25	634	0.074	767	0.09	0.83																		
10000		100	0.1	0.19	401	0.031	1173*	0.09		0.34*																

* ATTENZIONE: la coppia massima utilizzabile [T_{2M}] deve essere calcolata utilizzando il fattore di servizio:
T_{2M} = T₂ x FS'

* WARNING: Maximum allowable torque [T_{2M}] must be calculated using the following service factor:
T_{2M} = T₂ x FS'

* ACHTUNG: das max. anwendbare Drehmoment [T_{2M}] muss mit folgendem Betriebsfaktor berechnet werden:
T_{2M} = T₂ x FS'

Dati tecnici
Technical data
Technische Daten

50/89	$n_1 = 1400$					BXXA BSCRK - BBCRK		BKXC - BXXC - BXXF - BKKC BSCFK - BBCFK					BKXC - BXX.. - BKKC BSC..K - BBC..K							
	i_n	50	90	n_2	Rd	T_{2M} [Nm]	P [kW]	T_2 [Nm]	P_1 [kW]	FS'	Input - IEC						Classe / Class / Klasse [°C]			
		i_1	i_2								BKXC - BXXC - BKKC BSCFK - BBCFK		BXXF		3G	3D				
			B5/B14	B5	B14															
150	10	15	9.3	0.59	590	0.980	541	0.90	1.1	80	71	63	80	71	63	80	71	-	T4	130
200		20	7.0	0.57	638	0.819	584	0.75	1.1											
300		4.7	0.49	606	0.608	548	0.55	1.1												
450	15	20	3.1	0.46	606	0.426	527	0.37	1.1	-	63	80	71	63	80	71	-	T4	130	
600			2.3	0.45	606	0.327	463	0.25	1.3											
900	30	30	1.6	0.41	606	0.239	632	0.25	1.0	-	63	80	71	63	80	71	-	T4	130	
1200			1.2	0.39	606	0.191	573	0.18	1.1											
1500	50	30	0.9	0.36	606	0.165	662	0.18	0.9	-	63	80	71	63	80	71	-	T4	130	
1950			0.7	0.34	606	0.135	582	0.13	1.0											
2500	65	50	0.6	0.32	571	0.106	701	0.13	0.8	-	63	80	71	63	80	71	-	T4	130	
3250			0.4	0.30	571	0.087	853*	0.13	0.67*											
4000	80	50	0.4	0.28	571	0.076	977*	0.13	0.58*	-	63	80	71	63	80	71	-	T4	130	
5000			0.3	0.26	571	0.064	1153*	0.13	0.49*											
10000	100	100	0.1	0.20	361	0.027	1764*	0.13	0.20*											

50/90	$n_1 = 1400$					BXXA BSCRK - BBCRK		BKXC - BXXC - BXXF - BKKC BSCFK - BBCFK					BKXC - BXX.. - BKKC BSC..K - BBC..K							
	i_n	50	90	n_2	Rd	T_{2M} [Nm]	P [kW]	T_2 [Nm]	P_1 [kW]	FS'	Input - IEC						Classe / Class / Klasse [°C]			
		i_1	i_2								BKXC - BXXC - BKKC BSCFK - BBCFK		BXXF		3G	3D				
			B5/B14	B5	B14															
150	10	15	9.3	0.59	655	1.089	541	0.90	1.2	80	71	63	80	71	63	80	71	-	T4	130
200		20	7.0	0.57	709	0.910	584	0.75	1.2											
300		4.7	0.49	673	0.675	548	0.55	1.2												
450	15	20	3.1	0.46	673	0.473	527	0.37	1.3	-	63	80	71	63	80	71	-	T4	130	
600			2.3	0.45	673	0.363	463	0.25	1.5											
900	30	30	1.6	0.41	673	0.266	632	0.25	1.1	-	63	80	71	63	80	71	-	T4	130	
1200			1.2	0.39	673	0.212	573	0.18	1.2											
1500	50	30	0.9	0.36	673	0.183	662	0.18	1.0	-	63	80	71	63	80	71	-	T4	130	
1950			0.7	0.34	673	0.150	582	0.13	1.2											
2500	65	50	0.6	0.32	634	0.118	701	0.13	0.9	-	63	80	71	63	80	71	-	T4	130	
3250			0.4	0.30	634	0.097	853*	0.13	0.74*											
4000	80	50	0.4	0.28	634	0.084	977*	0.13	0.65*	-	63	80	71	63	80	71	-	T4	130	
5000			0.3	0.26	634	0.071	1153*	0.13	0.55*											
10000	100	100	0.1	0.20	401	0.030	1764*	0.13	0.23*											

* **ATTENZIONE:** la coppia massima utilizzabile [T_{2M}] deve essere calcolata utilizzando il fattore di servizio:
 $T_{2M} = T_2 \times FS'$

* **WARNING:** Maximum allowable torque [T_{2M}] must be calculated using the following service factor:
 $T_{2M} = T_2 \times FS'$

* **ACHTUNG:** das max. anwendbare Drehmoment [T_{2M}] muss mit folgendem Betriebsfaktor berechnet werden:
 $T_{2M} = T_2 \times FS'$

Dati tecnici

Technical data

Technische Daten

	$n_1 = 1400$					BXXA BSCRK - BBCRK		BKXC - BXXC - BXXF - BKKC BSCFK - BBCFK					BKXC - BXX.. - BKKC BSC..K - BBC..K							
	i_n	50		n_2	Rd	T_{2M} [Nm]	P [kW]	T_2 [Nm]	P_1 [kW]	FS'	Input - IEC						Classe / Class / Klasse [°C]			
		i_1	i_2								BKXC - BXXC - BKKC BSCFK - BBCFK			BXXF			3G	3D		
											B5/B14	B5	B14	B5	B14					
50/110	150	10	15	9.3	0.60	785	1.269	557	0.9	1.4	80	-	80	71	63	80	71	-	T4	130
	200		20	7.0	0.58	1000	1.265	712	0.9	1.4										
	300		30	4.7	0.50	1165	1.130	928	0.9	1.3										
	450	3.1		0.48	1165	0.791	1105	0.75	1.1											
	600	50	2.3	0.47	1165	0.608	1054	0.55	1.1	-	63	80	71	-	T4	130				
	900		30	1.6	0.43	1165	0.445	968	0.37								1.2			
	1200	40	1.2	0.40	1165	0.354	823	0.25	1.4	-	63	80	71	-	T4	130				
	1500	50	0.9	0.37	1165	0.306	952	0.25	1.2											
	1950	65	0.7	0.35	1150	0.248	1018	0.22	1.1	-	63	80	71	-	T4	130				
	2500	50	0.6	0.33	1119	0.200	1009	0.18	1.1											
	3250	65	100	0.4	0.31	1119	0.164	886	0.13	1.26	-	63	80	71	-	T4	130			
	4000	80		0.4	0.29	1119	0.143	1015	0.13	1.10										
	5000	100	0.3	0.27	1119	0.121	1198	0.13	0.93	-	63	80	71	-	T4	130				
	10000	100	0.1	0.21	727	0.051	1854*	0.13	0.39*											
63/110	150	10	15	9.3	0.61	1123	1.793	939	1.5	1.2	90	-	90	80	71	90	80	-	T4	130
	200		20	7.0	0.59	1229	1.536	1200	1.5	1.0										
	300		30	4.7	0.51	1165	1.116	1148	1.1	1.0										
	450	15		3.1	0.49	1165	0.781	1119	0.75	1.0										
	600	50	2.3	0.48	1165	0.593	1081	0.55	1.1	-	71	90	80	71	90	80	-	T4	130	
	900		30	1.6	0.44	1165	0.433	995	0.37											1.2
	1200	40	1.2	0.40	1165	0.370	1165	0.37	1.0	-	71	90	80	71	90	80	-	T4	130	
	1500	50	0.9	0.39	1165	0.292	998	0.25	1.2											
	1950	65	0.7	0.37	1165	0.239	1217	0.25	1.0	-	71	90	80	71	90	80	-	T4	130	
	2500	50	0.6	0.34	1119	0.190	1469	0.25	0.8											
	3250	65	100	0.4	0.32	1119	0.156	1792*	0.25	0.62*	-	71	90	80	71	90	80	-	T4	130
	4000	80		0.4	0.31	1119	0.133	2097*	0.25	0.53*										
	5000	100	0.3	0.28	1119	0.117	2395*	0.25	0.47*	-	71	90	80	71	90	80	-	T4	130	
	10000	100	0.1	0.22	727	0.049	3706*	0.25	0.20*											
63/130	150	10	15	9.3	0.64	1438	2.2	1176	1.8	1.2	90	-	90	80	71	90	80	-	T4	130
	200		20	7	0.61	1831	2.2	1498	1.8	1.2										
	300		30	4.7	0.53	1890	1.7	1627	1.5	1.2										
	450	15		3.1	0.49	1890	1.3	1655	1.1	1.1										
	600	50	2.3	0.47	1890	0.98	1731	0.9	1.1	-	71	90	80	71	90	80	-	T4	130	
	900		30	1.6	0.42	1890	0.73	1934	0.75											1
	1200	40	1.2	0.39	1890	0.59	1756	0.55	1.1	-	71	90	80	71	90	80	-	T4	130	
	1500	50	0.9	0.36	1890	0.51	2026	0.55	0.9											
	1950	65	0.7	0.34	1890	0.42	1673	0.37	1.1	-	71	90	80	71	90	80	-	T4	130	
	2500	50	0.6	0.33	1920	0.34	2082	0.37	0.9											
	3250	65	100	0.4	0.3	1920	0.29	1663	0.25	1.2	-	71	90	80	71	90	80	-	T4	130
	4000	80		0.4	0.29	1920	0.24	1978	0.25	1.1										
	5000	100	0.3	0.26	1920	0.22	2217	0.25	0.9	-	71	90	80	71	90	80	-	T4	130	
	10000	100	0.1	0.2	1276	0.09	3411	0.25	0.4											

* ATTENZIONE: la coppia massima utilizzabile $[T_{2M}]$ deve essere calcolata utilizzando il fattore di servizio:
 $T_{2M} = T_2 \times FS'$

* WARNING: Maximum allowable torque $[T_{2M}]$ must be calculated using the following service factor:
 $T_{2M} = T_2 \times FS'$

* ACHTUNG: das max. anwendbare Drehmoment $[T_{2M}]$ muss mit folgendem Betriebsfaktor berechnet werden:
 $T_{2M} = T_2 \times FS'$

Designazione

Designation

Bezeichnung

Riduttore epicicloidale Planetary gearbox Planetengetriebe	Grandezza Size Größe	Numero di stadi Steps Untersetzungsstufen	Coassiale Coaxial Koaxial	Rapporto di riduzione Ratio Untersetzungsverhältnis	Albero uscita Output shaft Durchmesser Abtriebswelle	Flangia uscita Output flange Ausgangsflansch	Albero entrata Input shaft Durchmesser Eingangswelle	Flangia in entrata Input flange Eingangsflansch	Posizione di montaggio Mounting position Baulege
BEP	55	2	C	100	A	A	AE..	P..	B5
	55 75 90 120 155	1 2	C	3 - 100	A T	A T Q	Vedi tabelle See tables Siehe Tab.	Vedi tabelle See tables Siehe Tab.	B5 V1 V3 OS

Per le dimensioni e le posizioni di montaggio vedere il "Catalogo dei Riduttori Epicicloidali Tramec".

For dimensions and mounting positions see the "Tramec Planetary Gearboxes Catalogue".

Informationen über Abmessungen und Montageposition sind in dem "Tramec Planetengetriebekatalog" zu finden.

Dati tecnici

Technical data

Technische Daten

BEP 55																	Stadi Steps Stufenzahl		
Stadi Steps Stufenzahl	1					2												1	2
i	3	4	5	7	10	9	12	15	16	20	25	28	35	40	50	70			
T _{2N}	12	14	16	12	10	14	16	16	16	16	16	16	16	16	16	14	12	n _{Inom}	4000
T _{2A}	22	24	24	22	20	24	28	28	28	28	28	28	28	28	28	24	22	n _{1max}	5000
T _{2S}	44	48	48	44	40	48	56	56	56	56	56	56	56	56	56	48	44	L _{pA}	< 70
J	Vedi cat. Tramec / see Tramec Catalogue / Siehe Tramec Katalog																L _h	20000	
R _t	1.0				0.9	1.0											0.9	F _{R2}	300
R _d	0.96					0.93											F _{A2}	450	
kg	0.8					1.8											α _{max}	8' 10'	

BEP 75																		Stadi Steps Stufenzahl		
Stadi Steps Stufenzahl	1					2														
i	3	4	5	7	10	9	12	15	16	20	25	28	35	40	50	70	100	1	2	
T _{2N}	22	28	32	28	20	26	32	36	36	36	36	36	36	36	36	30	22	n _{Inom}	4000	
T _{2A}	40	45	50	45	40	50	60	60	60	60	60	60	60	60	60	50	45	n _{Imax}	5000	
T _{2S}	80	90	100	90	80	100	120	120	120	120	120	120	120	120	120	100	90	LpA	< 70	
J	Vedi cat. Tramec / see Tramec Catalogue / Siehe Tramec Katalog																	Lh	20000	
R _t	35				3.0	3.5											3.0	F _{R2}	1800	
R _d	0.96					0.93													F _{A2}	1400
kg	1.4					2.0													α _{max}	8' 10'

BEP 90																		Stadi Steps Stufenzahl		
Stadi Steps Stufenzahl	1					2														
i	3	4	5	7	10	9	12	15	16	20	25	28	35	40	50	70	100	1	2	
T _{2N}	50	55	60	55	50	65	70	75	75	75	75	75	75	75	75	65	55	n _{Inom}	4000	
T _{2A}	80	90	100	90	80	100	110	120	120	120	120	120	120	120	120	100	90	n _{Imax}	5000	
T _{2S}	160	180	200	180	160	200	220	240	240	240	240	240	240	240	240	200	180	LpA	< 70	
J	Vedi cat. Tramec / see Tramec Catalogue / Siehe Tramec Katalog																	Lh	20000	
R _t	9.0				7.5	9.0											7.5	F _{R2}	2600	
R _d	0.96					0.93													F _{A2}	2000
kg	2.8					3.7													α _{max}	8' 10'

BEP 120																		Stadi Steps Stufenzahl		
Stadi Steps Stufenzahl	1					2														
i	3	4	5	7	10	9	12	15	16	20	25	28	35	40	50	70	100	1	2	
T _{2N}	120	150	180	150	100	150	180	220	220	220	220	220	220	220	220	170	110	n _{Inom}	3000	
T _{2A}	190	240	290	220	180	240	290	350	350	350	350	350	350	350	350	270	200	n _{Imax}	4000	
T _{2S}	400	500	600	460	380	500	600	700	700	700	700	700	700	700	700	540	400	LpA	< 70	
J	Vedi cat. Tramec / see Tramec Catalogue / Siehe Tramec Katalog																	Lh	20000	
R _t	32				28	32	30											28	F _{R2}	4500
R _d	0.96					0.93													F _{A2}	4000
kg	7.5					8.0													α _{max}	8' 10'

BEP 155																		Stadi Steps Stufenzahl		
Stadi Steps Stufenzahl	1					2														
i	3	4	5	7	10	9	12	15	16	20	25	28	35	40	50	70	100	1	2	
T _{2N}	240	320	380	300	220	320	400	500	500	500	500	500	500	500	500	350	250	n _{Inom}	3000	
T _{2A}	420	540	600	480	400	480	600	750	750	750	750	750	750	750	750	560	460	n _{Imax}	4000	
T _{2S}	880	1140	1260	1000	850	1000	1250	1500	1500	1500	1500	1500	1500	1500	1500	1120	920	LpA	< 70	
J	Vedi cat. Tramec / see Tramec Catalogue / Siehe Tramec Katalog																	Lh	20000	
R _t	60				50	60											50	F _{R2 (AA)} F _{R2 (TT)}	6500 5300	
R _d	0.96					0.93													F _{A2 (AA)} F _{A2 (TT)}	3250 2650
kg	10.9					15.7													α _{max}	8' 10'

Riduttore
epicicloidale BREP

Planetary
gearbox BREP

Planetengetriebe
BREP

Designazione

Designation

Bezeichnung

Riduttore epicicloidale Planetary gearbox Planetengetriebe	Grandezza Size Größe	Numero di stadi Steps Untersetzungsstufen	Coassiale Coaxial Koaxial	Rapporto di riduzione Ratio Untersetzungsverhältnis	Albero uscita Output shaft Durchmesser Abtriebswelle	Flangia uscita Output flange Ausgangsfiansch	Albero entrata Input shaft Durchmesser Eingangswelle	Flangia in entrata Input flange Eingangsfiansch	Posizione di montaggio Mounting position Baulage
BREP	075	2	C	100	AU16	FLT	AE12	P03	B5
	075 100 125 150	1 2 3	C	3 - 343	Vedi tabelle See tables Siehe Tab.	FLT FLQ	Vedi tabelle See tables Siehe Tab.	Vedi tabelle See tables Siehe Tab.	B5 V1 V3 OS

Per le dimensioni e le posizioni di montaggio vedere il "Catalogo dei Riduttori Epicicloidali Tramec".

For dimensions and mounting positions see the "Tramec Planetary Gearboxes Catalogue".

Informationen über Abmessungen und Montageposition sind in dem "Tramec Planetengetriebekatalog" zu finden.

Dati tecnici

Technical data

Technische Daten

BREP 75																					
Stadi Steps Stufenzahl	1				2								3								
i	3	4	5	6	9	12	16	20	24	30	36	27	36	48	64	80	100	120	144	180	216
n _{1 nom}	4000				4500								5000								
n _{1 max}	6000																				
T _{2N}	35	45	35	30	40	50	50	50	50	40	35	40	55	55	55	55	55	55	55	40	35
T _{2A}	55	65	55	50	60	70	70	70	70	60	55	60	80	80	80	80	80	80	80	60	55
T _{2S}	110	130	110	100	120	140	140	140	140	120	110	120	150	150	150	150	150	150	150	120	110
J	Vedi cat. Tramec / see Tramec Catalogue / Siehe Tramec Katalog																				
LpA	< 70																				
R _d	0.96				0.93								0.91								
L _h	20000																				
F _{R2}	1400																				
F _{A2}	700																				
R _t	4																				
α _{max}	4'				6'								8'								
kg	1.3				1.6								1.9								

Dati tecnici
Technical data
Technische Daten

BREP 100																					
Stadi Steps Stufenzahl	1					2							3								
i	3	4	5	6	9	12	16	20	24	30	36	27	36	48	64	80	100	120	144	180	216
n _{1 nom}	4000					4500							5000								
n _{1 max}	6000																				
T _{2N}	90	110	90	75	100	115	115	115	115	85	75	100	120	120	120	120	120	120	120	95	80
T _{2A}	145	170	130	120	160	180	180	180	180	140	130	160	190	190	190	190	190	190	190	150	130
T _{2S}	290	340	260	240	320	360	360	360	360	280	260	320	380	380	380	380	380	380	380	300	260
J	Vedi cat. Tramec / see Tramec Catalogue / Siehe Tramec Katalog																				
LpA	< 70																				
R _d	0.96					0.93							0.91								
L _h	20000																				
F _{R2}	2100																				
F _{A2}	1050																				
R _t	11																				
α _{max}	4'					6'							8'								
kg	2.7					3.5							4.3								

BREP 125																					
Stadi Steps Stufenzahl	1					2							3								
i	3	4	5	7	9	12	16	20	28	35	49	36	48	64	80	100	140	196	245	343	
n _{1 nom}	3000					3500							4000								
n _{1 max}	5000																				
T _{2N}	220	230	200	160	250	260	260	260	260	230	180	280	280	280	280	280	280	280	250	200	
T _{2A}	350	370	320	300	400	420	420	420	420	370	350	450	450	450	450	450	450	450	400	370	
T _{2S}	700	750	650	600	800	850	850	850	850	750	700	900	900	900	900	900	900	900	800	750	
J	Vedi cat. Tramec / see Tramec Catalogue / Siehe Tramec Katalog																				
LpA	< 70																				
R _d	0.96					0.93							0.91								
L _h	20000																				
F _{R2}	3700																				
F _{A2}	1850																				
R _t	32																				
α _{max}	4'					6'							8'								
kg	7.2					9.3							11.4								

BREP 150																					
Stadi Steps Stufenzahl	1					2							3								
i	3	4	5	7	9	12	16	20	28	35	49	36	48	64	80	100	140	196	245	343	
n _{1 nom}	3000					3500							4000								
n _{1 max}	5000																				
T _{2N}	430	470	410	340	500	560	560	560	560	470	370	600	600	600	600	600	600	600	500	450	
T _{2A}	700	750	650	600	800	900	900	900	900	750	700	950	950	950	950	950	950	950	800	750	
T _{2S}	1400	1500	1300	1200	1600	1800	1800	1800	1800	1500	1400	1900	1900	1900	1900	1900	1900	1900	1600	1500	
J	Vedi cat. Tramec / see Tramec Catalogue / Siehe Tramec Katalog																				
LpA	< 70																				
R _d	0.96					0.93							0.91								
L _h	20000																				
F _{R2}	6600																				
F _{A2}	3300																				
R _t	60																				
α _{max}	4'					6'							8'								
kg	13.0					17.0							21								

Riduttore
epicicloidale angolare BTEP

Right angle
planetary gearbox BTEP

Winkel-Planetengetriebe
BTEP

Designazione

Designation

Bezeichnung

Riduttore epicicloidale angolare Right angle planetary gearbox Winkel-planetengertriebe	Grandezza Size Größe	Numero di stadi Steps Untersetzungsstufen	Angolare Right angle Winkelgetriebe	Rapporto di riduzione Ratio Untersetzungsverhältnis	Albero uscita Output shaft Durchmesser Abtriebswelle	Flangia uscita Output flange Abtriebsflansch	Albero entrata Input shaft Antriebswelle	Flangia in entrata Input flange Eingangsfansch	Posizione di montaggio Mounting position Baulage
BTEP	55	2	T	100	A	A	AE..	P..	B5
	55 75 90 120 155	2 3	T	3 - 100	A T	A T Q	Vedi tabella See tables Siehe Tab.	Vedi tabella See tables Siehe Tab.	B5 B6 B8 V1 V3 O5

Per le dimensioni e le posizioni di montaggio vedere il "Catalogo dei Riduttori Epicicloidali Tramec".

For dimensions and mounting positions see the "Tramec Planetary Gearboxes Catalogue".

Informationen über Abmessungen und Montageposition sind in dem "Tramec Planetengetriebekatalog" zu finden.

Dati tecnici

Technical data

Technische Daten

BTEP 55																	Stadi Steps Stufenzahl		
Stadi Steps Stufenzahl	2					3													
i	3	4	5	7	10	9	12	15	16	20	25	28	35	40	50	70	100	2	3
T _{2N}	9	12	15	12	10	14	16	16	16	16	16	16	16	16	16	14	12	n _{1nom}	3500
T _{2A}	13	17	22	22	20	24	28	28	28	28	28	28	28	28	28	24	22	n _{1max}	5000
T _{2S}	26	34	44	44	40	48	56	56	56	56	56	56	56	56	56	48	44	LpA	< 65
J	Vedi cat. Tramec / see Tramec Catalogue / Siehe Tramec Katalog																Lh	20000	
R _t	0.85				0.8	0.85											0.8	F _{R2}	300
R _d	0.94					0.91											F _{A2}	450	
kg	1.3					2.3											α _{max}	17 ' 20 '	

BTEP 75																		Stadi Steps Stufenzahl		
Stadi Steps Stufenzahl	2					3														2
i	3	4	5	7	10	9	12	15	16	20	25	28	35	40	50	70	100			
T _{2N}	18	25	30	28	20	26	32	36	36	36	36	36	36	36	36	30	22	n _{1nom}	3000	
T _{2A}	30	40	50	45	40	50	60	60	60	60	60	60	60	60	60	50	45	n _{1max}	4500	
T _{2S}	60	80	100	90	80	100	120	120	120	120	120	120	120	120	120	100	90	LpA	< 68	
J	Vedi cat. Tramec / see Tramec Catalogue / Siehe Tramec Katalog																	Lh	20000	
R _t	2.5					2	2.5											2	F _{R2}	1800
R _d	0.94					0.91												F _{A2}	1400	
kg	2.4					3												α _{max}	15 ' 18 '	

BTEP 90																		Stadi Steps Stufenzahl		
Stadi Steps Stufenzahl	2					3														2
i	3	4	5	7	10	9	12	15	16	20	25	28	35	40	50	70	100			
T _{2N}	32	42	54	55	50	65	70	75	75	75	75	75	75	75	75	65	55	n _{1nom}	3000	
T _{2A}	50	66	84	90	80	100	110	120	120	120	120	120	120	120	120	100	90	n _{1max}	4500	
T _{2S}	100	132	168	180	160	200	220	240	240	240	240	240	240	240	240	200	180	LpA	< 68	
J	Vedi cat. Tramec / see Tramec Catalogue / Siehe Tramec Katalog																	Lh	20000	
R _t	6.5					6	6.5											6	F _{R2}	2600
R _d	0.94					0.91												F _{A2}	2000	
kg	4.6					5.5												α _{max}	15 ' 18 '	

BTEP 120																		Stadi Steps Stufenzahl		
Stadi Steps Stufenzahl	2					3														2
i	3	4	5	7	10	9	12	15	16	20	25	28	35	40	50	70	100			
T _{2N}	60	80	100	140	100	150	180	180	180	180	180	180	180	180	180	170	110	n _{1nom}	2500	
T _{2A}	108	144	180	220	180	240	290	290	290	290	290	290	290	290	290	270	200	n _{1max}	4000	
T _{2S}	216	288	360	440	380	500	600	600	600	600	600	600	600	600	600	540	400	LpA	< 70	
J	Vedi cat. Tramec / see Tramec Catalogue / Siehe Tramec Katalog																	Lh	20000	
R _t	16					14.5	16											14.5	F _{R2}	4500
R _d	0.94					0.91												F _{A2}	4000	
kg	11.7					12.2												α _{max}	12 ' 15 '	

BTEP 155																		Stadi Steps Stufenzahl		
Stadi Steps Stufenzahl	2					3														2
i	3	4	5	7	10	9	12	15	16	20	25	28	35	40	50	70	100			
T _{2N}	170	230	290	300	220	320	400	430	430	430	430	430	430	430	430	350	250	n _{1nom}	2500	
T _{2A}	270	360	450	480	400	480	600	650	650	650	650	650	650	650	650	560	460	n _{1max}	4000	
T _{2S}	540	720	900	1000	850	1000	1250	1300	1300	1300	1300	1300	1300	1300	1300	1120	920	LpA	< 70	
J	Vedi cat. Tramec / see Tramec Catalogue / Siehe Tramec Katalog																	Lh	20000	
R _t	34.5					31	34.5											31	F _{R2 (AA)} F _{R2 (TT)}	6500 5300
R _d	0.94					0.91												F _{A2 (AA)} F _{A2 (TT)}	3250 2650	
kg	17.5					22												α _{max}	12 ' 15 '	

Designazione

Designation

Bezeichnung

Meccatronica applicata Applied mechatronic Angewandte Mechatronik	Grandezza Size Größe	Numero di stadi Steps Untersetzungsstufen	Coassiale Coaxial Koaxial	Rapporto di riduzione Ratio Untersetzungsverhältnis	Tipo di albero uscita Type of output shaft Typ der Ausgangswelle	Diametro albero uscita Diameter of output shaft Durchmesser Abtriebswelle	Flangia uscita Output flange Ausgangsflansch	Albero entrata Input shaft Durchmesser Eingangswelle	Flangia in entrata / Senza flangia Input flange / Without flange Eingangsflansch / Ohne Flansch	Posizione di montaggio Mounting position Eingangsflansch			
BMTA	16	1	C	3	PL	AU16	FLQ	AE9	Q101	B5			
BMTA	16	1 2	C	3	PL	AU16	FLQ	AE9	Q101	T101	B5 V1 V3 OS		
	22			
	32		
	40		
55	100	PC	AU55	AE48	Q507	T504	NF			

Per le dimensioni e le posizioni di montaggio vedere il "Catalogo dei Riduttori Epicicloidali di Precisione Tramec".

For dimensions and mounting positions see the "Tramec Precision Planetary Gearboxes Catalogue".

Informationen über Abmessungen und Montageposition sind in dem "Tramec Hochgenauigkeits Planetengetriebekatalog" zu finden.

Dati tecnici

Technical data

Technische Daten

BMTA 16																
Stadi Steps Stufenzahl	1					2										
i	3	4	5	7	10	12	16	20	25	28	35	40	50	70	100	
$n_{1\text{nom}}$	3500	3500	3500	4000	4000	4000	4500	4500	4500	4500	4500	5000	5000	5000	5000	
$n_{1\text{max}}$	5500					6000										
100'000 h (1)	T_{2N}	35	40	40	36	33	40	40	41	41	43	41	43	41	37	32
	T_{2A}	68	68	64	56	46	70	70	70	66	70	66	70	66	58	48
	T_{2S}	110	135	130	110	92	140	140	140	135	140	135	140	135	115	95
25'000 h (1)	T_{2N}	45	52	50	47	35	56	58	60	60	63	60	63	60	52	40
	T_{2A}	72	72	68	60	50	74	74	74	70	74	70	74	70	60	50
	T_{2S}	115	140	135	120	100	145	145	145	140	145	140	145	140	120	100
R_d	0.97					0.94										
F_{R2}	2000					2500										
F_{A2}	2000					2500										
R_t	4.5															
α_{max}	4'					6'										
kg	2.1					3.3										

(1) La durata indicata si riferisce alla vita degli ingranaggi e non dei cuscinetti per i quali è necessario determinare la durata secondo le prescrizioni riportate nel "Catalogo dei Riduttori Epicicloidali di Precisione Tramec" paragrafo: "Carichi esterni su albero lento e durata dei cuscinetti uscita"

(1) The duration indicated refers to the life of the gears and not of the bearings, for which a life must be determined based on the indications given in "Tramec Precision Planetary Gearboxes Catalogue", paragraph: "External loads on output shaft and duration of the output bearings"

(1) Die angezeigte Lebensdauer bezieht sich auf die Zahnräder, nicht auf die Lager, deren Lebensdauer gemäß den im "Tramec Hochgenauigkeits Planetengetriebekatalog" angeführten Anweisungen bestimmt werden muss Abschnitt "Externe Belastungen auf der langsamen Welle und Lebensdauer der Ausgangslager"

Dati tecnici
Technical data
Technische Daten

BMTA 22																
Stadi Steps Stufenzahl	1					2										
i	3	4	5	7	10	12	16	20	25	28	35	40	50	70	100	
n_{1 nom}	3000	3000	3000	3500	3500	3500	4000	4000	4000	4000	4000	4500	4500	4500	4500	
n_{1 max}	5000					5500										
100'000 h (1)	T_{2N}	67	82	80	74	62	86	88	90	90	93	87	92	86	78	68
	T_{2A}	125	135	125	115	90	140	140	140	130	140	130	145	130	120	95
	T_{2S}	220	270	250	225	180	280	280	280	260	280	260	285	260	230	185
25'000 h (1)	T_{2N}	85	105	100	95	65	115	115	120	115	125	115	125	115	100	72
	T_{2A}	130	140	130	120	95	145	145	145	135	145	135	150	135	125	100
	T_{2S}	230	285	265	235	190	290	295	295	275	295	275	300	275	245	195
R_d	0.97					0.94										
F_{R2}	3150					4000										
F_{A2}	3150					4000										
R_t	10															
α_{max}	4'					6'										
kg	3.7					4.8										

BMTA 32																
Stadi Steps Stufenzahl	1					2										
i	3	4	5	7	10	12	16	20	25	28	35	40	50	70	100	
n_{1 nom}	2500	2500	2500	3000	3000	3000	3500	3500	3500	3500	3500	4000	4000	4000	4000	
n_{1 max}	4500					5000										
100'000 h (1)	T_{2N}	145	200	190	180	130	210	215	220	215	230	225	235	220	200	145
	T_{2A}	295	320	300	255	205	340	340	340	315	340	315	340	315	275	210
	T_{2S}	550	650	600	520	410	680	680	680	630	690	630	690	635	550	420
25'000 h (1)	T_{2N}	185	255	250	215	140	280	280	285	260	290	265	290	265	230	155
	T_{2A}	310	340	320	270	215	355	360	360	330	360	330	360	330	290	220
	T_{2S}	570	680	630	540	430	710	710	720	660	720	660	720	660	580	440
R_d	0.97					0.94										
F_{R2}	5000					6300										
F_{A2}	5000					6300										
R_t	30															
α_{max}	3'					5'										
kg	8.1					10.3										

(1) La durata indicata si riferisce alla vita degli ingranaggi e non dei cuscinetti per i quali è necessario determinare la durata secondo le prescrizioni riportate nel "Catalogo dei Riduttori Epicycloidali di Precisione Tramec" paragrafo: "Carichi esterni su albero lento e durata dei cuscinetti uscita"

(1) The duration indicated refers to the life of the gears and not of the bearings, for which a life must be determined based on the indications given in "Tramec Precision Planetary Gearboxes Catalogue", paragraph: "External loads on output shaft and duration of the output bearings"

(1) Die angezeigte Lebensdauer bezieht sich auf die Zahnräder, nicht auf die Lager, deren Lebensdauer gemäß den im "Tramec Hochgenauigkeits Planetengetriebekatalog" angeführten Anweisungen bestimmt werden muss Abschnitt "Externe Belastungen auf der langsamen Welle und Lebensdauer der Ausgangslager"

BMTA 40																
Stadi Steps Stufenzahl	1					2										
i	3	4	5	7	10	12	16	20	25	28	35	40	50	70	100	
n _{1 nom}	2000	2000	2000	2500	2500	2500	3000	3000	3000	3000	3000	3500	3500	3500	3500	
n _{1 max}	4000					4500										
100'000 h (1)	T _{2N}	300	390	375	355	290	420	420	430	425	450	440	460	435	390	320
	T _{2A}	685	750	725	655	450	780	790	800	760	800	760	800	765	685	460
	T _{2S}	1200	1440	1380	1250	860	1500	1510	1520	1450	1530	1460	1540	1460	1310	880
25'000 h (1)	T _{2N}	380	500	485	460	310	550	550	570	560	590	585	610	585	540	350
	T _{2A}	720	790	760	685	475	825	830	835	795	840	800	840	800	720	480
	T _{2S}	1250	1500	1450	1310	910	1570	1580	1590	1520	1600	1520	1610	1530	1370	920
R _d	0.97					0.94										
F _{R2}	8000					10000										
F _{A2}	8000					10000										
R _t	63															
α _{max}	3'					5'										
kg	14.1					20.4										

BMTA 55																
Stadi Steps Stufenzahl	1					2										
i	3	4	5	7	10	12	16	20	25	28	35	40	50	70	100	
n _{1 nom}	1600	1600	1600	2000	2000	2000	2500	2500	2500	2500	2500	3000	3000	3000	3000	
n _{1 max}	3500					4000										
100'000 h (1)	T _{2N}	670	930	910	845	750	1000	1000	1030	1020	1070	1050	1090	1070	960	840
	T _{2A}	1400	1680	1640	1480	1045	1780	1780	1800	1725	1820	1735	1820	1740	1565	1060
	T _{2S}	2450	3000	2900	2620	1850	3150	3160	3180	3050	3200	3070	3230	3080	2770	1880
25'000 h (1)	T _{2N}	840	1185	1165	1095	810	1310	1320	1360	1350	1415	1395	1440	1420	1300	905
	T _{2A}	1470	1770	1720	1550	1100	1865	1870	1880	1800	1900	1815	1900	1820	1640	1110
	T _{2S}	2550	3120	3020	2730	1920	3280	3280	3310	3170	3340	3200	3360	3200	2880	1950
R _d	0.97					0.94										
F _{R2}	12500					16000										
F _{A2}	12500					16000										
R _t	232															
α _{max}	3'					5'										
kg	29.8					38.5										

(1) La durata indicata si riferisce alla vita degli ingranaggi e non dei cuscinetti per i quali è necessario determinare la durata secondo le prescrizioni riportate nel "Catalogo dei Riduttori Epicicloidali di Precisione Tramec" paragrafo: "Carichi esterni su albero lento e durata dei cuscinetti uscita"

(1) The duration indicated refers to the life of the gears and not of the bearings, for which a life must be determined based on the indications given in "Tramec Precision Planetary Gearboxes Catalogue", paragraph: "External loads on output shaft and duration of the output bearings"

(1) Die angezeigte Lebensdauer bezieht sich auf die Zahnräder, nicht auf die Lager, deren Lebensdauer gemäß den im "Tramec Hochgenauigkeits Planetengetriebekatalog" angeführten Anweisungen bestimmt werden muss Abschnitt "Externe Belastungen auf der langsamen Welle und Lebensdauer der Ausgangslager"

Servo riduttori
ipoidi BHTA

Hypoid servo
gearboxes BHTA

Hypoid-Servo-Getriebe
BHTA

Designazione

Designation

Bezeichnung

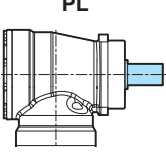
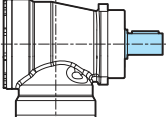
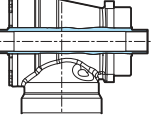
Trasmissione ipoidi per l'automazione Hypoid transmission for automation Hypoidgetriebe für die Automatisierung	Grandezza Size Größe	Numero di stadi Number of stages Anzahl der Stufen	Ortagonale Orthogonal Orthogonale	Rapporto di riduzione Ratio Untersetzungsverhältnis	Tipo di albero uscita Type of output shaft Typ der Abtriebswelle	Diametro albero uscita Diameter of output shaft Durchmesser Abtriebswelle	Flangia uscita Output flange Abtriebflansch	Albero entrata Input shaft Antriebswelle	Flangia in entrata / Senza flangia Input flange / Without flange Antriebflansch/Ohne Flansch	Posizione di montaggio Mounting position Einbaulage
BHTA	16	1	T	3	PL	AU15	FLQ	AE9	Q101	B5
BHTA	16 22 32 40 55	1 2	T	3 ... 100	  	AU15 ... AU55	FLQ	AE9 ... AE48	Q101 ... Q507 Senza flangia Without flange Ohne Flansch NF82 ... NF192	B5 B6 B7 B8 V1 V3 OS

(*) Nel caso di albero uscita HW, si fornisce anche un calettatore, sufficiente per il corretto funzionamento del riduttore.

(*) In the case of the HW output shaft, a shrink disk is also supplied, which is sufficient for the correct operation of the gearbox.

(*) Bei der HW-Abtriebswelle wird zusätzlich eine Schrumpfscheibe mitgeliefert, die für den korrekten Betrieb des Getriebes ausreichend ist.

Per le dimensioni e le posizioni di montaggio vedere il "Catalogo dei Riduttori Epicycloidali di Precisione Tramec".

For dimensions and mounting positions see the "Tramec Precision Planetary Gearboxes Catalogue".

Informationen über Abmessungen und Montageposition sind in dem "Tramec Hochgenauigkeits Planetengetriebekatalog" zu finden.

BHTA 16															
Stadi Steps Stufenzahl	1					2									
i	3	4	5	7	10	12	16	20	25	28	35	40	50	70	100
n₁ nom	2500	2700	3000	3000	3000	4500	4500	4500	4500	4500	4500	5000	5000	5000	5000
n₁ max	6000					6000									
100'000 h	T_{2N}	26	28	28	26	19	28	28	28	28	28	28	28	26	19
	T_{2A}	31	33	33	31	23	33	33	33	33	33	33	33	31	23
	T_{2S}	52	56	56	52	38	56	56	56	56	56	56	56	56	52
R_d	0.96					0.94									
F_{R2}	2000					2400									
F_{A2}	2000					2400									
R_t	2														
α max	5'					5'									
kg	3.2					4.4									

BHTA 22															
Stadi Steps Stufenzahl	1					2									
i	3	4	5	7	10	12	16	20	25	28	35	40	50	70	100
n₁ nom	2300	2500	2800	2800	2800	4000	4000	4000	4000	4000	4000	4500	4500	4500	4500
n₁ max	5500					5500									
100'000 h	T_{2N}	52	60	60	56	43	60	60	60	60	60	60	60	56	43
	T_{2A}	65	70	70	68	52	70	70	70	70	70	70	70	68	52
	T_{2S}	120	120	120	110	86	120	120	120	120	120	120	120	120	110
R_d	0.96					0.94									
F_{R2}	3400					4000									
F_{A2}	3400					4000									
R_t	6														
α max	4'					4'									
kg	4.7					5.7									

BHTA 32																
Stadi Steps Stufenzahl	1					2										
i	3	4	5	7	10	12	16	20	25	28	35	40	50	70	100	
n₁ nom	2200	2400	2500	2500	2500	3000	3000	3000	3000	3000	3000	3000	3500	4000	4000	
n₁ max	4500					4500										
100'000 h	T_{2N}	100	125	125	120	105	125	125	125	125	125	125	125	120	105	
	T_{2A}	140	160	160	150	125	160	160	160	150	160	150	160	150	145	125
	T_{2S}	200	250	250	240	210	250	250	250	240	250	240	250	240	230	210
R_d	0.96					0.94										
F_{R2}	5000					6300										
F_{A2}	5000					6300										
R_t	13															
α max	4'					4'										
kg	11.5					12.5										

BHTA 40																
Stadi Steps Stufenzahl	1					2										
i	3	4	5	7	10	12	16	20	25	28	35	40	50	70	100	
$n_{1 \text{ nom}}$	1800	2000	2000	2000	2000	2500	3000	3000	300	3000	3000	3000	3000	3000	3000	
$n_{1 \text{ max}}$	4000					4500										
100'000 h	T_{2N}	200	265	265	245	220	265	265	265	265	265	265	265	265	245	220
	T_{2A}	300	315	315	295	265	315	315	315	315	315	315	315	315	295	265
	T_{2S}	400	530	530	490	440	530	530	530	530	530	530	530	530	490	440
R_d	0.96					0.94										
F_{R2}	8000					9500										
F_{A2}	8000					9500										
R_t	38															
α_{max}	4'					4'										
kg	22					24										

BHTA 55																
Stadi Steps Stufenzahl	1					2										
i	3	4	5	7	10	12	16	20	25	28	35	40	50	70	100	
$n_{1 \text{ nom}}$	1600	1800	1800	1800	1800	2000	2500	2500	2500	2500	2500	3000	3000	3000	3000	
$n_{1 \text{ max}}$	4000					4000										
100'000 h	T_{2N}	420	530	530	500	390	530	530	530	530	530	530	530	530	500	390
	T_{2A}	580	640	640	600	470	640	640	640	640	640	640	640	640	600	470
	T_{2S}	840	1060	1060	1000	780	1060	1060	1060	1060	1060	1060	1060	1060	1000	780
R_d	0.96					0.94										
F_{R2}	12500					14500										
F_{A2}	12500					14500										
R_t	80															
α_{max}	4'					4'										
kg	46					50										

Designazione

Designation

Bezeichnung

Tipo Type Typ	Grandezza Size Größe	Albero uscita diam. mm Output shaft diam. mm Abtriebswelle Durchmesser mm	Flangia uscita diam. mm Output flange diam. mm Abtriebsflansch Durchmesser mm	Attacco motore IEC IEC motor adaptor IEC Motoranbau	Posizione di montaggio Mounting position Einbaulage	Posizione scatola di comando Speed control box position Lage des Steuerkastens	Potenza motore Motor power Motorleistung	N° poli Poles number Polzahl	Forma costruttiva motore Motor version Motorversion	Tensione Voltage Spannung	Frequenza Frequency Frequenz	Posizione morsettiere Terminal box position Lage des Klemmkastens
BNF	030	AU28	F250	100B5	B5	SA	2.2 kW	4	B5	230/400	50Hz	MA
BN BNM BNF	003 005 010 020 030 050	Vedi tabella	Vedi tabella	Vedi tabella	B3 B6 B7 B8 V5 V6 B5 V1 V3	SA SB SC SD	Vedi tabella See tables Siehe Tabelle	2 4 6	B5			MA MB MC MD

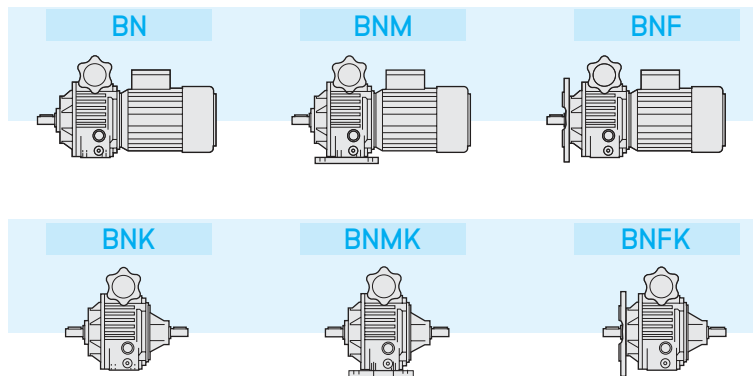

Per le dimensioni, gli accessori e le posizioni di montaggio vedere il "Catalogo dei Riduttori ad Ingranaggi Ortogonali e Paralleli Tramec".

For dimensions, accessories and mounting positions see the "Tramec Helical and Bevel Helical Gearboxes Catalogue".

Informationen über Abmessungen, Ersatzteile und Montageposition sind in dem "Tramec Untersetzungsgetriebekatalog" zu finden.

Variatori
serie BNR

Variators
BNR series

Verstellgetriebe
Serie BNR

Designazione

Designation

Bezeichnung

Tipo Type Typ	Grandezza Size Größe	Rapporto di riduzione (i) Reduction ratio (i) Untersetzungsverhältnis	Albero uscita diam. mm Output shaft diam. mm Abtriebswelle Durchmesser mm	Flangia uscita diam. mm Output flange diam. mm Abtriebsflansch Durchmesser mm	Attacco motore IEC IEC motor adaptor IEC Motoranbau	Posizione di montaggio Mounting position Einbaulage	Posizione scatola di comando Speed control box position Lage des Steuerkastens	Potenza motore Motor power Motorleistung	N° poli Poles number Polzahl	Forma costruttiva motore Motor version Motorversion	Tensione Voltage Spannung	Frequenza Frequency Frequenz	Posizione morsettiere Terminal box position Lage des Klemmkastens
BNRF	003/1	5	AU19	F160	63B5	B5	SA	0.25 kW	4	B5	230/400	50Hz	MA
BNRT BNRM BNRF BNRTK BNRMK BNRFK	003/1 005/1 010/1 020/1 030/1 050/1	2.5 5	Vedi tabelle See tables Siehe Tabelle	Vedi tabelle See tables Siehe Tabelle	Vedi tabelle See tables Siehe Tabelle	B3 B6 B7 B8 V5 V6 B5 V1 V3	SA SB SC SD	Vedi tabelle See tables Siehe Tabelle	2 4 6	B5			MA MB MC MD

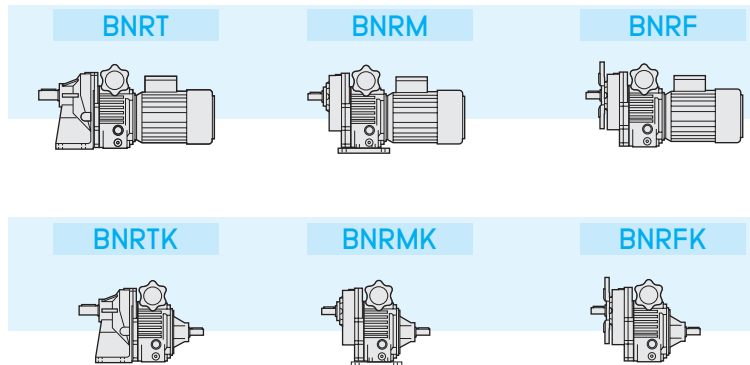

Per le dimensioni, gli accessori e le posizioni di montaggio vedere il "Catalogo dei Riduttori ad Ingranaggi Ortogonali e Paralleli Tramec".

For dimensions, accessories and mounting positions see the "Tramec Helical and Bevel Helical Gearboxes Catalogue".

Informationen über Abmessungen, Ersatzteile und Montageposition sind in dem "Tramec Untersetzungsgetriebekatalog" zu finden.

Dati tecnici
Technical data
Technische Daten

Tipo Type Typ	P ₁ kW	Poli Poles Polen	Attacco motore IEC IEC motor adaptor IEC Motoranbau	n ₂ max min ⁻¹	n ₂ min min ⁻¹	i	T ₂ min Nm	T ₂ max Nm
BNR...003	0.25	4	63 B5	950	190	—	1.9	3.8
	0.37	2	63 B5	1900	380	—	1.5	3
BNR...003/1	0.25	4	63 B5	380	76	2.5	4.7	9.3
				190	38	5	9.3	18.6
BN...005	0.37	4	71 B5	1000	167	—	3	6
	0.55	4	71 B5	1000	167	—	4.5	9
	0.75	2	71 B5	2000	333	—	3	6
BNR...005/1	0.37	4	71 B5	400	67	2.5	7.3	14.7
				200	33	5	14.7	29.4
BN...010	0.75	4	80 B5	1000	167	—	6	12
	0.92	4	80 B5	1000	167	—	7.5	12
	1.5	2	80 B5	2000	333	—	6	12
BNR...010/1	0.75	4	80 B5	400	67	2.5	14.7	29.4
				200	33	5	29.4	58.8
BN...020	1.5	4	90 B5	1000	167	—	12	24
	1.85	4	90 B5	1000	167	—	15	24
	2.2	2	90 B5	2000	333	—	9	18
BNR...020/1	1.5	4	90 B5	400	67	2.5	29.4	58.8
				200	33	5	58.8	118
BN...030	2.2	6	100 B5	660	125	—	27	54
	2.2	4	100 B5	1000	167	—	18	36
	3	4	100 B5	1000	167	—	24	48
BNR...030/1	2.2	4	100 B5	400	67	2.5	44.1	88.2
				200	33	5	88.2	176
BN...050	4	4	112 B5	1000	167	—	32	64
BNR...050/1	4	4	112 B5	400	67	2.5	78.4	157
				200	33	5	157	314

**Variatori
serie BUDL**
**Variators
BUDL series**
**Verstellgetriebe
Serie BUDL**
Designazione
Designation
Bezeichnung

Tipo Type Typ	Grandezza Size Größe	Albero uscita diam. mm Output shaft diam. mm Abtriebswelle Durchmesser mm	Flangia uscita diam. mm Output flange diam. mm Abtriebsflansch Durchmesser mm	Attacco motore IEC IEC motor adaptor IEC Motoranbau	Posizione di montaggio Mounting position Einbaulage	Potenza motore Motor power Motorleistung	N° poli Poles number Polzahl	Forma costruttiva motore Motor version Motorversion	Tensione Voltage Spannung	Frequenza Frequency Frequenz
BUDL	010	AU19	F200	80B5	B5	0.75 kW	4	B5	230/400	50Hz
BUDL	002 005 010	AU 11 AU 14 AU 19	F 140 F 160 F 200	63 B5 71 B5 80 B5	B5 V1 V3	0.18 0.25 0.37 0.55 0.75	4	B5	230/400	50Hz

Per le dimensioni, gli accessori e le posizioni di montaggio vedere il "Catalogo dei Riduttori ad Ingranaggi Ortogonali e Paralleli Tramec".

For dimensions, accessories and mounting positions see the "Tramec Helical and Bevel Helical Gearboxes Catalogue".

Informationen über Abmessungen, Ersatzteile und Montageposition sind in dem "Tramec Untersetzungsgetriebekatalog" zu finden.

Dati tecnici
Technical data
Technische Daten

Tipo Type Typ	P ₁ kW	Poli Poles Polen	Attacco motore IEC IEC motor adaptor IEC Motoranbau	n ₂ max min ⁻¹	n ₂ min min ⁻¹	T ₂ min Nm	T ₂ max Nm
UDL 002	0.18	4	63 B5	880	170	1.5	3
UDL 005	0.25	4	71 B5	1000	200	2	6
	0.37			1000	200	3	6
UDL 010	0.55	4	80 B5	1000	200	4.4	12
	0.75	4		1000	200	6	12

	CONDIZIONI GENERALI DI VENDITA	TERMS AND CONDITIONS OF SALE	ALLGEMEINE GESCHÄFTSBEDINGUNGEN	
1.	Processo d'offerta	<i>Offer Process</i>	Angebotsverfahren	D2
2.	Processo d'ordine	<i>Order Process</i>	Auftragsverfahren	D2
3.	Conferma d'ordine	<i>Order Confirmation</i>	Auftragsbestätigung	D3
4.	Prezzo dei prodotti	<i>Price of the products</i>	Preis der Produkte	D3
5.	Pagamenti e clausola di "solve et repete"	<i>Payment and "solve et repete" clause</i>	Zahlungen und die Klausel „solve et repete“	D3
6.	Riserva di proprietà	<i>Retention of title</i>	Eigentumsvorbehalt	D4
7.	Spedizione e trasporto	<i>Shipping and transport</i>	Versand und Transport	D4
8.	Termini di consegna	<i>Terms of delivery</i>	Lieferbedingungen	D4
9.	Reclami, non conformità e restituzione	<i>Complaints, non-conformities and returns</i>	Reklamationen, Nichtkonformität und Rückgabe	D5
10.	Garanzie sui prodotti	<i>Product warranties</i>	Produktgarantie	D5
11.	Proprietà intellettuale e industriale	<i>Intellectual and industrial property</i>	Geistiges und gewerbliches Eigentum	D6
12.	Inadempimento del Cliente	<i>Non-fulfilment by the Customer</i>	Nichterfüllung durch den Kunden	D6
13.	Modifiche alle CGV	<i>Modifications to the GTC</i>	Änderungen der AGB	D6
14.	Legge applicabile e Foro competente	<i>Applicable Law and Jurisdiction</i>	Anwendbares Recht und Gerichtsstand	D6

Le presenti condizioni generali di vendita (le "CGV") definiscono e regolano, inderogabilmente, termini e condizioni di ogni fornitura da parte di Tramec S.r.l., con sede in Milano, Corso Venezia n. 36, codice fiscale 03553380373 ("Tramec"). Tramec e il Cliente, congiuntamente, le "Parti".

1. Processo d'offerta

Su richiesta scritta del Cliente, Tramec - direttamente o ricorrendo alla propria rete di distribuzione - formulerà per iscritto un'offerta al Cliente per l'acquisto dei prodotti dallo stesso richiesti (l'"Offerta").

Tramec si obbliga a mantenere ferma l'Offerta per 30 giorni di calendario, restando inteso che (i) il Cliente sarà libero di accettarla o di non accettarla e che (ii) decorso tale termine, la stessa non sarà più vincolante per Tramec che, quindi, non avrà alcun obbligo verso il Cliente.

L'Offerta è da intendersi riservata e non divulgabile.

2. Processo d'ordine

L'ordine di acquisto (l'"Ordine"), con il quale il Cliente dichiara di accettare l'Offerta, deve pervenire a Tramec, nel termine di 30 giorni di calendario previsto al paragrafo (1), mediante comunicazione a mezzo pec, email, raccomandata a/r o fax, su carta intestata del Cliente, che riporti espressamente: (i) riferimento dell'Offerta, (ii) codice del prodotto, (iii) descrizione del prodotto, (iv) quantità richiesta, (v) prezzi offerti, (vi) termini e condizioni di pagamento e (vii) termini e condizioni di consegna.

Qualora, previo accordo scritto fra Tramec e il Cliente, quest'ultimo segnali che un ordine debba essere evaso con urgenza, la comunicazione di cui al precedente capoverso dovrà riportare altresì espressamente (viii) la dicitura "PROCEDURA DI URGENZA". In tal caso, potrà essere concordata dalle Parti (i) la consegna entro 5 giorni lavorativi, con una maggiorazione del 15% calcolato sul totale lordo "ex works" dell'Ordine (in aggiunta agli importi netti totali) o (ii) la consegna entro 9 giorni lavorativi, con una maggiorazione del 7% calcolato sul totale lordo "ex works" dell'Ordine (in aggiunta agli importi netti totali). Il Cliente è consapevole e accetta che gli ordini con dicitura "PROCEDURA D'URGENZA", se accettati da Tramec, non sono più modificabili né cancellabili.

Resta inteso che la data di consegna, ove espressa in numero di giorni, è sempre da intendersi in termini di giorni lavorativi decorrenti dal giorno successivo alla data di comunicazione di accettazione dell'Ordine da parte di Tramec (la "Conferma d'Ordine").

These general terms and conditions of sale (the "GTC") define and regulate, without exception, the terms and conditions of any supply by Tramec S.r.l., with registered office in Milan, Corso Venezia 36, tax code 03553380373 ("Tramec"). Tramec and the Customer, jointly, the "Parties".

1. Offer Process

Upon the written request of the Customer, Tramec - either directly or through its distribution network - shall make an offer in writing to the Customer for the purchase of the products requested by the same (the "Offer").

Tramec undertakes to keep the Offer valid for 30 calendar days, it being understood that (i) the Customer shall be free to accept or refuse to accept it and that (ii) once this period has expired, the same shall no longer be binding for Tramec, which shall therefore have no obligation towards the Customer.

The Offer is to be considered confidential and non-disclosable.

2. Order Process

The purchase order (the "Order"), with which the Customer declares his acceptance of the Offer, must be received by Tramec, within the term of 30 calendar days provided for in paragraph (1), by means of a communication by certified email, email, registered letter with return receipt or fax, on headed paper of the Customer, expressly stating: (i) Offer reference, (ii) product code, (iii) product description, (iv) quantity required, (v) prices offered, (vi) terms and conditions of payment and (vii) terms and conditions of delivery.

If, by written agreement between Tramec and the Customer, the latter indicates that an order must be processed urgently, the communication referred to in the preceding paragraph shall also expressly state (viii) the words "URGENCY PROCEDURE". In this case, delivery within 5 working days may be agreed by the Parties (i) with a surcharge of 15% calculated on the gross "ex works" total of the Order (in addition to the total net amounts) or (ii) delivery within 9 working days, with a surcharge of 7% calculated on the gross "ex works" total of the Order (in addition to the total net amounts). The Customer is aware and accepts that orders marked "URGENCY PROCEDURE", if accepted by Tramec, can no longer be modified or cancelled.

It is understood that the delivery date, when expressed in number of days, shall always be understood in terms of working days starting from the day following the date of communication of acceptance of the Order by Tramec (the "Order Confirmation").

Die vorliegenden allgemeinen Geschäftsbedingungen (die „AGB“) definieren und regeln ausnahmslos die Bedingungen für alle Lieferungen von Tramec S.r.l. mit Sitz in Mailand, Corso Venezia 36, Steuernummer 03553380373 („Tramec“). Tramec und der Kunde, werden beide als die „Parteien“ bezeichnet.

1. Angebotsverfahren

Auf schriftliche Anfrage des Kunden unterbreitet Tramec – entweder direkt oder über sein Vertriebsnetz – dem Kunden ein schriftliches Angebot für den Kauf der von ihm gewünschten Produkte (das „Angebot“).

Tramec verpflichtet sich, das Angebot 30 Kalendertage lang aufrechtzuerhalten, wobei es (i) dem Kunden freisteht, es anzunehmen oder abzulehnen, und (ii) es nach Ablauf dieser Frist für Tramec nicht mehr bindend ist, so dass Tramec keine Verpflichtung gegenüber dem Kunden hat.

Das Angebot ist vertraulich zu behandeln und darf nicht offengelegt werden.

2. Auftragsverfahren

Der Kaufauftrag (der „Auftrag“), mit dem der Kunde seine Annahme des Angebots erklärt, muss innerhalb der in Absatz (1) vorgesehenen Frist von 30 Kalendertagen bei Tramec eingehen, und zwar durch eine Mitteilung per Post, E-Mail, Einschreiben mit Rückschein oder Fax auf Briefpapier des Kunden, in der ausdrücklich wie folgt angegeben wird: (i) Angebotsbezug, (ii) Produktcode, (iii) Produktbeschreibung, (iv) gewünschte Menge, (v) angebotene Preise, (vi) Zahlungsbedingungen und (vii) Lieferbedingungen.

Wenn Tramec und der Kunde schriftlich vereinbaren, dass ein Auftrag dringend bearbeitet werden muss, muss die im vorstehenden Absatz genannte Mitteilung auch ausdrücklich den Vermerk (viii) „EILVERFAHREN“ enthalten. In einem solchen Fall können die Parteien eine Lieferung innerhalb von 5 Arbeitstagen vereinbaren (i), mit einem Aufschlag von 15 % auf den Bruttobetrag „ab Werk“ des Auftrags (zusätzlich zu den gesamten Nettobeträgen) oder (ii) eine Lieferung innerhalb von 9 Arbeitstagen mit einem Aufschlag von 7 % auf den Bruttobetrag „ab Werk“ des Auftrags (zusätzlich zu den gesamten Nettobeträgen). Der Kunde ist sich bewusst und akzeptiert, dass Aufträge mit dem Vermerk „EILVERFAHREN“, wenn sie von Tramec angenommen werden, nicht mehr geändert oder storniert werden können.

Es wird vereinbart, dass die Lieferfrist, wenn sie in Tagen ausgedrückt wird, immer in Arbeitstagen ab dem Tag nach dem Datum der Mitteilung der Annahme der Bestellung durch Tramec (die „Auftragsbestätigung“) zu verstehen ist.

3. Conferma d'ordine

Il processo di vendita dei prodotti si intenderà concluso - e comporterà obblighi in capo a Tramec - solo ed esclusivamente a seguito dell'invio da parte di Tramec della Conferma d'Ordine al Cliente.

La Conferma d'Ordine verrà trasmessa mediante comunicazione a mezzo pec, e-mail, raccomandata a/r o fax, su carta intestata di Tramec e dovrà essere conforme all'Ordine effettuato dal Cliente, riportando pedissequamente i medesimi (i) riferimento dell'Offerta e dell'Ordine, (ii) codice del prodotto, (iii) descrizione del prodotto, (iv) quantità richiesta, (v) termini e condizioni di pagamento e (vi) termini e condizioni di consegna. In particolare, queste ultime dovranno necessariamente tener conto dell'eventuale indicazione come "PROCEDURA D'URGENZA".

Trascorsi 2 giorni lavorativi dall'invio della Conferma d'Ordine, Tramec riterrà confermato l'Ordine da parte del Cliente ed ogni inesattezza eventualmente contenuta e non contestata in forma scritta da parte del Cliente nel già menzionato termine non sarà più contestabile o annullabile.

Eventuali contestazioni o correzioni richieste nei 2 giorni lavorativi successivi all'invio della Conferma d'Ordine determineranno la possibilità di revisionare l'Ordine o l'Offerta, a seconda della necessità.

4. Prezzo dei prodotti

L'Offerta e l'Ordine conterranno esclusivamente i prezzi previsti, nel periodo di riferimento, nei listini vigenti di Tramec. Qualora si trattasse di un prodotto non incluso nei listini, lo stesso sarà oggetto di separata quotazione da parte di Tramec. Tramec si riserva di revisionare periodicamente i listini prezzi che, tuttavia, non saranno applicabili retroattivamente agli Ordini che sono già stati oggetto di Conferma d'Ordine da parte di Tramec.

I prezzi indicati nei listini, nell'Offerta e nella Conferma d'Ordine di Tramec sono calcolati franco fabbrica, al netto dell'IVA, di eventuali sconti, nonché dei costi di imballaggio, spedizione e trasporto (che saranno oggetto di separata quotazione).

5. Pagamenti e clausola di "solve et repete"

Tramec emetterà la fattura relativa all'Ordine, al più tardi, al momento della spedizione dello stesso. Salvo diverso accordo fra le Parti, la valuta di riferimento sarà esclusivamente l'Euro.

3. Order Confirmation

The sales process of the products shall be considered concluded - and shall entail obligations for Tramec - only and exclusively after Tramec has sent the Order Confirmation to the Customer.

The Order Confirmation shall be transmitted by certified email, email, registered letter with return receipt or fax, on Tramec headed paper, and shall be in conformity with the Order placed by the Customer, indicating precisely the same (i) Offer and Order reference, (ii) product code, (iii) product description, (iv) requested quantity, (v) terms and conditions of payment and (vi) terms and conditions of delivery. In particular, the latter must necessarily take into account any indication such as "URGENCY PROCEDURE".

After 2 working days from the dispatch of the Order Confirmation, TRAMEC will consider the order confirmed by the Customer and any inaccuracy contained and not disputed in writing by the Customer within the aforementioned period can no longer be disputed or cancelled.

Any disputes or corrections requested within 2 working days after dispatch of the Order Confirmation shall result in the Order or Offer being revised as necessary.

4. Price of the products

The Offer and the Order shall contain exclusively the prices envisaged, in the reference period, in the current Tramec price lists. If a product is not included in the price lists, it shall be the subject of a separate quotation by Tramec. Tramec reserves the right to revise the price lists from time to time, which, however, shall not apply retroactively to Orders that have already been subject to Order Confirmation by Tramec.

The prices indicated in the price lists, in the Offer and in the Tramec Order Confirmation are calculated ex-works, net of VAT, any discounts, as well as packaging, shipping and transport costs (which shall be quoted separately).

5. Payment and "solve et repete" clause

Tramec shall issue the invoice for the Order, at the latest, at the time of its dispatch. Unless otherwise agreed between the Parties, the reference currency shall be exclusively the Euro.

3. Auftragsbestätigung

Der Verkaufsprozess der Produkte gilt erst und ausschließlich dann als abgeschlossen - und bringt Verpflichtungen für Tramec mit sich -, wenn Tramec die Auftragsbestätigung an den Kunden geschickt hat.

Die Auftragsbestätigung wird per Post, per E-Mail, per Einschreiben mit Rückschein oder per Fax auf dem Briefpapier von Tramec übermittelt und stimmt mit dem vom Kunden erteilten Auftrag überein, wobei (i) die Angebots- und Auftragsnummer, (ii) der Produktcode, (iii) die Produktbeschreibung, (iv) die gewünschte Menge, (v) die Zahlungsbedingungen und (vi) die Lieferbedingungen genau angegeben werden. Letztere müssen insbesondere die Angabe als „EILVERFAHREN“ unbedingt berücksichtigen.

Nach Ablauf von 2 Arbeitstagen nach dem Versand der Auftragsbestätigung betrachtet Tramec den Auftrag als vom Kunden bestätigt, und eventuelle Ungenauigkeiten, die der Kunde nicht innerhalb der vorgenannten Frist schriftlich beanstandet hat, können nicht mehr angefochten oder storniert werden.

Einwände oder Korrekturen, die innerhalb von 2 Arbeitstagen nach Absendung der Auftragsbestätigung angefordert werden, führen dazu, dass der Auftrag oder das Angebot entsprechend überarbeitet wird.

4. Preis der Produkte

Das Angebot und der Auftrag enthalten ausschließlich die Preise, die in den aktuellen Preislisten von Tramec für den betreffenden Zeitraum vorgesehen sind. Wenn ein Produkt nicht in der Preisliste enthalten ist, wird es von Tramec separat angeboten. Tramec behält sich das Recht vor, die Preislisten von Zeit zu Zeit zu abzuändern, was jedoch nicht rückwirkend für Bestellungen gilt, die bereits von Tramec mit der Auftragsbestätigung bestätigt wurden.

Die in den Preislisten, im Angebot und in der Auftragsbestätigung von Tramec angegebenen Preise verstehen sich ab Werk, ohne Mehrwertsteuer, eventuelle Rabatte sowie Verpackungs-, Versand- und Transportkosten (die gesondert ausgewiesen werden).

5. Zahlungen und die Klausel „solve et repete“

Tramec stellt die Rechnung für den Auftrag spätestens beim Versand der Bestellung aus. Sofern die Vertragsparteien nichts anderes vereinbaren, ist die Referenzwährung ausschließlich der Euro.

La Conferma d'Ordine riporterà dettagliatamente termini e condizioni di pagamento, per i quali il Cliente non potrà opporre alcuna eccezione, quand'anche di totale inadempimento, al fine di evitare o ritardare il pagamento del prezzo.

Ogni giorno di ritardo nel pagamento rispetto ai termini indicati nella Conferma d'Ordine darà diritto a Tramec di pretendere nei confronti del Cliente il pagamento degli interessi di mora, ai sensi del D.Lgs. 231/2002.

6. Riserva di proprietà

Ai sensi dell'art. 1523 cod. civ., nel caso in cui il pagamento del prezzo non avvenisse anticipatamente in unica soluzione, Tramec manterrà la proprietà dei prodotti venduti al Cliente fino alla completa corresponsione del prezzo. La presente clausola di riserva di proprietà, obbliga il Cliente a compiere tutti gli adempimenti previsti per legge, ove previsto, per rendere valida ed eseguibile nei confronti di tutti i terzi tale vincolo.

7. Spedizione e trasporto

La spedizione e il trasporto vengono effettuati tramite vettori indicati dal Cliente o, in alternativa, scelti da Tramec, fermo restando che spedizione e trasporto (i) avvengono a spese e rischi del Cliente, (ii) non sono coperti da assicurazioni di Tramec, (iii) non sono garantiti da Tramec e (iv) avvengono sempre "franco fabbrica".

8. Termini di consegna

I termini di consegna indicati nella Conferma d'Ordine, pur essendo meramente indicativi, devono intendersi come stabiliti salvo il verificarsi di eventi scusabili, tra i quali, a titolo esemplificativo e non esaustivo (i) ritardi da parte del Cliente nel fornire dati tecnici o amministrativi necessari alla spedizione dei prodotti; (ii) cause di forza maggiore, con ciò intendendosi qualsiasi atto estraneo alla volontà delle parti (guerra; rivolta; terrorismo; disordini civili; pandemia ed epidemia; restrizioni governative; divieti o decreti di alcun genere; regolamenti di importazione o esportazione; ostruzione di strade private o pubbliche; sciopero, serrata o controversie commerciali, sia che coinvolgano i dipendenti di Tramec sia quelli di qualsiasi altra persona; difficoltà nell'ottenere manodopera o materiali; guasto dei macchinari; fuoco; incidente; o eventi meteorologici avversi); (iii) ritardi dovuti a terzi o allo spedizioniere.

The Order Confirmation shall contain detailed terms and conditions of payment, for which the Customer may not raise any objection, even of total non-performance, in order to avoid or delay the payment of the price.

Each day of delay in payment with respect to the terms indicated in the Order Confirmation shall entitle Tramec to claim from the Customer the payment of interest on arrears, pursuant to Legislative Decree no. 231/2002.

6. Retention of title

In accordance with art. 1523 of the Civil Code, in the event that payment of the price is not made in advance in a lump sum, Tramec shall retain ownership of the products sold to the Customer until the price has been paid in full. This retention of title clause obliges the Customer to fulfil all legal obligations, where applicable, to make this obligation valid and enforceable against all third parties.

7. Shipping and transport

Shipping and transport are carried out by carriers indicated by the Customer or, alternatively, chosen by Tramec, it being understood that shipping and transport (i) take place at the expense and risk of the Customer, (ii) are not covered by Tramec's insurance, (iii) are not guaranteed by Tramec and (iv) always take place "ex-works".

8. Terms of delivery

The delivery terms indicated in the Order Confirmation, although purely indicative, shall be understood as established unless excusable events occur, including but not limited to (i) delays by the Customer in providing technical or administrative data necessary for the shipment of the products; (ii) force majeure, by which is meant any act beyond the control of the parties (war; revolt; terrorism; civil unrest; pandemic and epidemic; government restrictions; prohibitions or decrees of any kind; import or export regulations; obstruction of private or public roads; strikes, lockouts or commercial disputes, whether involving Tramec's employees or those of any other person; difficulties in obtaining labour or materials; machinery breakdown; fire; accident; or adverse weather events); (iii) delays due to third parties or to the shipper.

Die Auftragsbestätigung enthält detaillierte Zahlungsbedingungen, gegen die der Kunde keine Einwände erheben kann, auch nicht bei vollständiger Nichterfüllung, um die Zahlung des Preises zu vermeiden oder zu verzögern.

Jeder Tag des Zahlungsverzugs in Bezug auf die in der Auftragsbestätigung angegebenen Fristen berechtigt Tramec, vom Kunden die Zahlung von Verzugszinsen gemäß dem Gesetzesdekret Nr. 231/2002.

6. Eigentumsvorbehalt

Gemäß Artikel 1523 des italienischen Bürgerlichen Gesetzbuchs behält sich Tramec, falls die Zahlung des Preises nicht im Voraus in einer Summe erfolgt, das Eigentum an den an den Kunden verkauften Produkten vor, bis der Preis vollständig bezahlt ist. Diese Eigentumsvorbehaltsklausel verpflichtet den Kunden zur Erfüllung aller rechtlichen Verpflichtungen, sofern vorgesehen, um vorliegende Vereinbarung gegenüber Dritten gültig und durchsetzbar zu machen.

7. Versand und Transport

Versand und Transport erfolgen durch vom Kunden angegebene oder von Tramec gewählte Spediteure, wobei Versand und Transport (i) auf Kosten und Risiko des Kunden erfolgen, (ii) nicht von Tramec versichert werden, (iii) nicht von Tramec garantiert werden und (iv) immer „ab Werk“ erfolgen.

8. Lieferbedingungen

Die in der Auftragsbestätigung angegebenen Lieferfristen sind zwar rein indikativ, gelten aber als feststehend, es sei denn, es treten unentschuldbare Ereignisse ein, einschließlich, aber nicht beschränkt auf (i) Verspätungen des Kunden bei der Bereitstellung technischer oder administrativer Daten, die für den Versand der Produkte erforderlich sind; (ii) höhere Gewalt, worunter jede Handlung verstanden wird, die sich der Kontrolle der Parteien entzieht (Krieg, Aufruhr, Terrorismus, innere Unruhen Pandemien und Epidemien, staatliche Beschränkungen, Verbote oder Verordnungen jeglicher Art, Einfuhr- oder Ausfuhrbestimmungen, Blockierung privater oder öffentlicher Straßen, Streiks, Aussperrungen oder Handelsstreitigkeiten, an denen Mitarbeiter von Tramec oder anderer Personen beteiligt sind, Schwierigkeiten bei der Beschaffung von Arbeitskräften oder Materialien, Maschinenausfall, Brand, Unfall oder widrige Witterungsbedingungen); (iii) Verzögerungen durch Dritte oder den Spediteur.

9. Reclami, non conformità e restituzione

Il Cliente sarà tenuto a segnalare per iscritto ogni tipologia di reclamo in forma scritta all'ufficio post-vendita all'indirizzo e-mail customer.care@tramec.it entro e non oltre 10 giorni dalla data di consegna. Eventuali reclami derivati da vizi o difetti dei prodotti evidenziati, per la loro natura, successivamente alla data di consegna, dovranno anch'essi essere segnalati per all'indirizzo sopra riportato entro e non oltre 5 giorni dalla data di rilevazione del vizio o difetto, e comunque saranno ritenuti tali entro e non oltre il periodo di garanzia riportato nel punto 10.

Il Cliente sarà tenuto a segnalare per iscritto - esclusivamente a mezzo pec, fax, raccomandata a/r o e-mail ed entro e non oltre 5 giorni di calendario dalla consegna dei prodotti - eventuali difformità (in termini di qualità o quantità) rispetto alla Conferma d'Ordine. Trascorso il termine di cui sopra senza comunicazioni di difformità, i prodotti si intenderanno accettati nello stato di fatto in cui versano. Eventuali vizi occulti, fermo l'onere della prova della non conoscenza o conoscibilità del vizio a carico del Cliente, dovranno essere segnalati entro e non oltre 2 giorni di calendario dalla scoperta e, comunque, entro 1 mese dall'avvenuta consegna.

La restituzione dei prodotti dal Cliente a Tramec potrà avvenire solo ed esclusivamente nel caso in cui sia stata concordata con Tramec, a seguito della segnalazione di difformità di cui al precedente capoverso. Resta comunque inteso che la restituzione avverrà a cura, spese e rischio del Cliente.

10. Garanzie sui prodotti

Tramec, ai sensi della vigente normativa, garantisce i propri prodotti per 1 anno dalla data di fatturazione degli stessi ed esclusivamente per difetti di costruzione, montaggio o progettazione. In tal caso, Tramec sarà tenuta a riparare e, ove impossibile, a sostituire (a proprie cura e spese) il prodotto.

In ogni caso, il Cliente riconosce che Tramec non potrà in alcun modo essere chiamata a rispondere per eventuali danni - diretti o indiretti, per danno emergente o lucro cessante - subiti dal Cliente o da terzi.

9. Complaints, non-conformities and returns

The Customer must report any complaints in writing to the after-sales department at customer.care@tramec.it no later than 10 days from the date of delivery.

Any claims arising from defects or faults in the products that are discovered, by their nature, after the date of delivery, must also be reported to the above address within and no later than 5 days from the date of discovery of the defect or fault, and shall in any case be deemed to have occurred within and no later than the guarantee period stated in point 10.

The Customer must report in writing - exclusively by certified email, fax, registered letter with return receipt or email within and no later than 5 calendar days after delivery of the products - any discrepancies (in terms of quality or quantity) with respect to the Order Confirmation. After the expiry of the aforementioned period without notice of discrepancies, the products shall be deemed to be accepted in their current state. Any hidden defects, without prejudice to the burden of proof that the Customer does not know or cannot know the defect, must be reported no later than 2 calendar days after discovery and, in any case, no later than 1 month after delivery.

The return of the products by the Customer to Tramec may take place only and exclusively in the case in which it has been agreed with Tramec, following the notification of discrepancies as per the previous paragraph. It is in any case understood that the return shall be made at the care, expense and risk of the Customer.

10. Product warranties

Tramec, in accordance with current legislation, guarantees its products for 1 year from the date of invoicing of the same and exclusively for manufacturing, assembly or design defects. In this case Tramec shall be obliged to repair the product and, where impossible, to replace it (at its own expense).

In any case, the Customer acknowledges that Tramec cannot in any way be held liable for any damage - direct or indirect, for consequential damage or loss of profit - suffered by the Customer or by third parties.

9. Reklamationen, Nichtkonformität und Rückgabe

Der Kunde ist verpflichtet, seine Reklamationen innerhalb von 10 Tagen nach der Lieferung schriftlich an die Kundendienstabteilung unter customer.care@tramec.it zu melden. Reklamationen aufgrund von Mängeln oder Fehlern an den Produkten, die aufgrund ihrer Beschaffenheit nach dem Lieferdatum festgestellt werden, müssen ebenfalls innerhalb von 5 Tagen nach Feststellung des Mangels oder Fehlers an die oben genannte Adresse gemeldet werden und gelten in jedem Fall als innerhalb der in Abschnitt 10 genannten Garantiezeit entstanden.

Der Kunde muss spätestens 5 Kalendertage nach Lieferung der Produkte schriftlich - ausschließlich per Post, Fax, Einschreiben mit Rückschein oder E-Mail - etwaige Abweichungen (in Bezug auf Qualität oder Menge) von der Auftragsbestätigung zu melden. Nach Ablauf der vorgenannten Frist, ohne dass etwaige Unstimmigkeiten gemeldet wurden, gelten die Produkte ihrem derzeitigen Zustand als angenommen. Versteckte Mängel, wobei die Beweislast für die Unkenntnis oder das Nichtwissen des Mangels beim Kunden liegt, innerhalb von 2 Kalendertagen nach ihrer Entdeckung und in jedem Fall innerhalb eines Monats nach Lieferung gemeldet werden.

Die Rücksendung der Produkte durch den Kunden an Tramec kann nur und ausschließlich erfolgen, wenn die mit Tramec vereinbart und nachdem der Mangel im Sinne des vorherigen Absatzes gemeldet wurde. Es versteht sich in jedem Fall, dass die Rücksendung auf Rechnung und Risiko des Kunden erfolgt.

10. Produktgarantie

Tramec gibt auf seine Produkte gemäß der geltenden Gesetzgebung ab dem Datum der Rechnungsstellung und ausschließlich für Herstellungs-, Montage- oder Konstruktionsfehler eine Garantie von 1 Jahr. In diesem Fall ist Tramec verpflichtet, das Produkt zu reparieren und, falls dies nicht möglich ist, zu ersetzen (auf eigene Kosten).

In jedem Fall erkennt der Kunde an, dass Tramec in keiner Weise für Schäden - direkt oder indirekt, für Folgeschäden oder entgangenen Gewinn - haftbar gemacht werden kann, die dem Kunden oder Dritten entstehen.

Tramec non sarà tenuta a rispondere o a prestare garanzia per (i) riparazioni, modifiche o manomissioni effettuate dal Cliente (o da tecnici non autorizzati) senza consenso scritto da parte di Tramec, (ii) prodotti privi della targhetta originale di fabbrica di Tramec, (iii) uso negligente, improprio o contrario alle prescrizioni sull'uso, manutenzione e conservazione dei prodotti da parte del Cliente e (iv) prodotti per i quali il Cliente non abbia ancora integralmente corrisposto il prezzo. Inoltre, Tramec non garantisce la rispondenza dei prodotti a normative, regolamenti e standard diversi da quelli dell'Unione Europea.

Tramec shall not be liable or provide a warranty for (i) repairs, modifications or tampering carried out by the Customer (or by unauthorised technicians) without the written consent of Tramec, (ii) products without the original Tramec factory label, (iii) negligent, improper use or use contrary to the instructions on the use, maintenance and conservation of the products by the Customer and (iv) products for which the Customer has not yet paid the price in full. Furthermore, Tramec does not guarantee the compliance of products with regulations, rules and standards other than those of the European Union.

Tramec übernimmt keine Haftung oder Garantie für (i) Reparaturen, Änderungen oder Veränderungen, die vom Kunden (oder von nicht zugelassenen Technikern) ohne die schriftliche Zustimmung von Tramec vorgenommen wurden, (ii) Produkte ohne das Originaletikett von Tramec, (iii) fahrlässige, unsachgemäße oder gegen die Anweisungen zur Verwendung, Wartung und Lagerung der Produkte verstoßende Verwendung durch den Kunden und (iv) Produkte, für die der Kunde noch nicht den vollen Preis bezahlt hat. Darüber hinaus garantiert Tramec nicht die Übereinstimmung der Produkte mit anderen Vorschriften, Regeln und Normen als denen der Europäischen Union.

11. Proprietà intellettuale e industriale

Il Cliente riconosce e accetta che Tramec sia l'unica titolare dei diritti di proprietà intellettuale e industriale legati ai prodotti e al loro processo produttivo e che l'acquisto di prodotti non determina il sorgere di alcun diritto, licenza o autorizzazione in favore del Cliente. Ogni utilizzo della proprietà intellettuale e industriale di proprietà Tramec dovrà essere autorizzato in forma scritta da Tramec stessa.

11. Intellectual and industrial property

The Customer acknowledges and accepts that Tramec is the sole owner of the intellectual and industrial property rights related to the products and their production process and that the purchase of products does not give rise to any right, license or authorization in favour of the Customer. Any use of Tramec's intellectual and industrial property rights must be authorized in writing by Tramec itself.

11. Geistiges und gewerbliches Eigentum

Der Kunde erkennt an und akzeptiert, dass Tramec alleiniger Inhaber der geistigen und gewerblichen Eigentumsrechte in Bezug auf die Produkte und deren Herstellungsverfahren ist und, dass der Kauf von Produkten keinerlei Rechte, Lizenzen oder Genehmigungen zugunsten des Kunden begründet. Jede Nutzung der geistigen und gewerblichen Eigentumsrechte von Tramec muss von Tramec schriftlich genehmigt werden.

12. Inadempimento del Cliente

Tramec avrà facoltà di sospendere l'Ordine o la consegna dei prodotti o di pretendere la restituzione degli stessi (nell'ipotesi di riserva di proprietà di cui al precedente punto 6.) in ogni caso di inadempimento o violazione da parte del Cliente degli obblighi assunti ai sensi delle presenti CGV o qualora Tramec abbia fondato motivo di temere una riduzione delle garanzie patrimoniali prestate o generiche del Cliente.

12. Non-fulfilment by the Customer

Tramec shall have the right to suspend the Order or the delivery of products or to demand the return of the same (in the case of retention of title as referred to in point 6. above) in any case of non-fulfilment or violation by the Customer of the obligations undertaken in accordance with these GTC or if Tramec has justified reasons to fear a reduction in the financial guarantees given or general guarantees of the Customer.

12. Nichterfüllung durch den Kunden

Tramec hat das Recht, den Auftrag oder die Lieferung der Produkte auszusetzen oder deren Rückgabe zu verlangen (im Falle eines Eigentumsvorbehalts im Sinne von Punkt 6), wenn der Kunde die in diesen AGB festgelegten Verpflichtungen nicht erfüllt oder verletzt oder wenn Tramec berechtigte Gründe hat, eine Verringerung der vom Kunden geleisteten finanziellen Garantien oder allgemeinen Garantien zu befürchten.

13. Modifiche alle CGV

Tramec si riserva il diritto di modificare unilateralmente le previsioni delle CGV, dandone notizia al Cliente, che avrà 30 giorni di calendario dalla comunicazione delle nuove CGV per manifestare il proprio recesso, in assenza del quale si intenderanno accettate e da applicarsi a ogni ordine successivo alla data di trasmissione al Cliente delle nuove CGV.

13. Modifications to the GTC

Tramec reserves the right to unilaterally modify the provisions of the GTC, giving notice to the Customer, who shall have 30 calendar days from the communication of the new GTC to express his withdrawal, failing which they shall be deemed accepted and to be applied to any order after the date of transmission of the new GTC to the Customer.

13. Änderungen der AGB

Tramec behält sich das Recht vor, die Bestimmungen der AGB einseitig zu ändern und den Kunden davon in Kenntnis zu setzen. Dieser erhält eine Frist von 30 Kalendertagen ab der Übermittlung der neuen AGB, um seinen Rücktritt zu erklären, andernfalls gelten sie als angenommen und werden auf alle Bestellungen nach dem Datum der Übermittlung der neuen AGB an den Kunden angewendet.

14. Legge applicabile e Foro competente

Le presenti CGV e ogni Offerta, Ordine o Conferma d'Ordine saranno soggetti alla legge italiana. Qualsiasi controversia a essi relativi, in punto di validità, efficacia, esecuzione o interpretazione sarà devoluta in via esclusiva alla competenza del Tribunale di Milano.

14. Applicable Law and Jurisdiction

These GTC and any Offer, Order or Order Confirmation shall be subject to Italian law. Any dispute relating to them, as to their validity, effectiveness, execution or interpretation shall be deferred exclusively to the jurisdiction of the Court of Milan.

14. Anwendbares Recht und Gerichtsstand

Die vorliegenden AGB und jedes Angebot, jede Bestellung und jede Auftragsbestätigung unterliegen dem italienischen Recht. Für alle Streitigkeiten in Bezug auf ihre Gültigkeit, Wirksamkeit, Ausführung oder Auslegung ist ausschließlich das Gericht von Mailand zuständig.

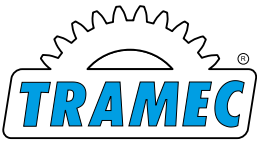

HEADQUARTER:

Tramec srl
Via Bizzarri, 6
40012 Calderara di Reno
Bologna (Italy)
www.tramec.it

PRODUCTION SITES:

Ber-Mar srl
Via C. Bassi, 28/A - 40015
San Vincenzo di Galliera
Bologna (Italy)
www.bermar.it

MT Motori Elettrici srl
via Bologna, 175 - 40017
San Giovanni in Persiceto
Bologna (Italy)
www.electricmotorsmt.com

Varmec srl
Via dell'Industria, 13
36016 Thiene
Vicenza (Italy)
www.varmec.com

BRANCHES ITALY:

Italtech srl
(Centro)
www.italtech1.it

Tramec Sud srl
(Sud)
www.tramecsud.it

Tramec Technology srl
(Nord)
www.tramectechnology.it

FOREIGN BRANCHES:

Tramec France sarl
(Francia)
www.tramec.fr

Tramec Getriebe gmbh
(Germania)
www.tramec-getriebe.de

Tramec Polska SP. Z O.O.
(Polonia)
www.tramec.pl

TVT Motion AB
(Svezia)
www.tvtmotion.se

ATEX ATMOSFERE ESPLOSIVE

ATEX
Explosive Atmospheres

ATEX
Explosive Atmosphæren

03/2024



Ihr Service- und Vertriebspartner:
TRAMEC Getriebe GmbH
 Senefelderstraße 3
 77933 Lahr / Schwarzwald
 Tel.: 07821-99 49 701
 info@tramec-getriebe.de
 www.tramec-getriebe.de

